

JÁRNBENT STEYPA Starfsmannaástaða Undirstöðufestingar

Undirstöðubitar í starfsmannaástaðu
Grunnmynd 1:50

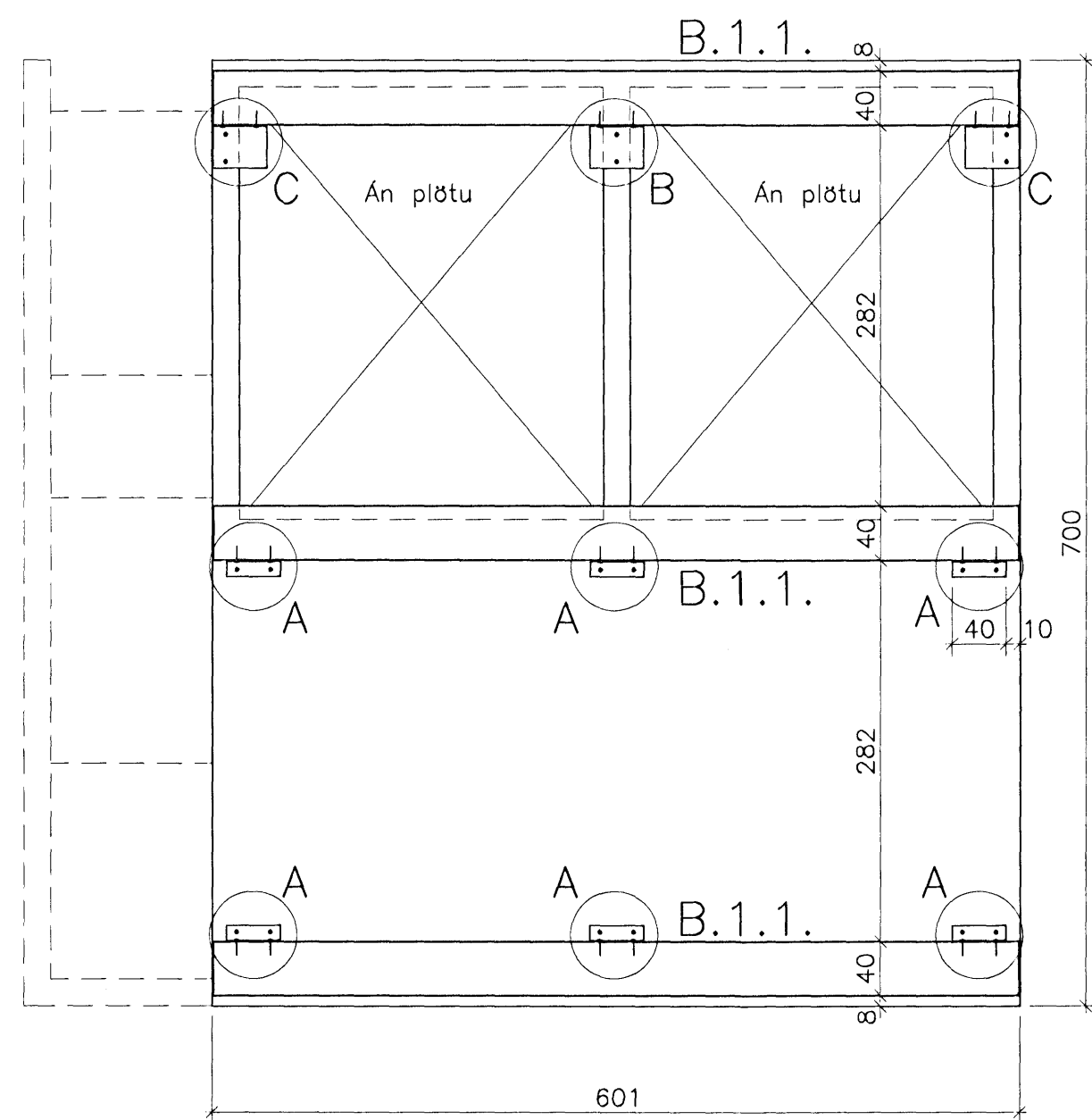

Gámafestingar í starfsmannaástaðu
Grunnmynd 1:50

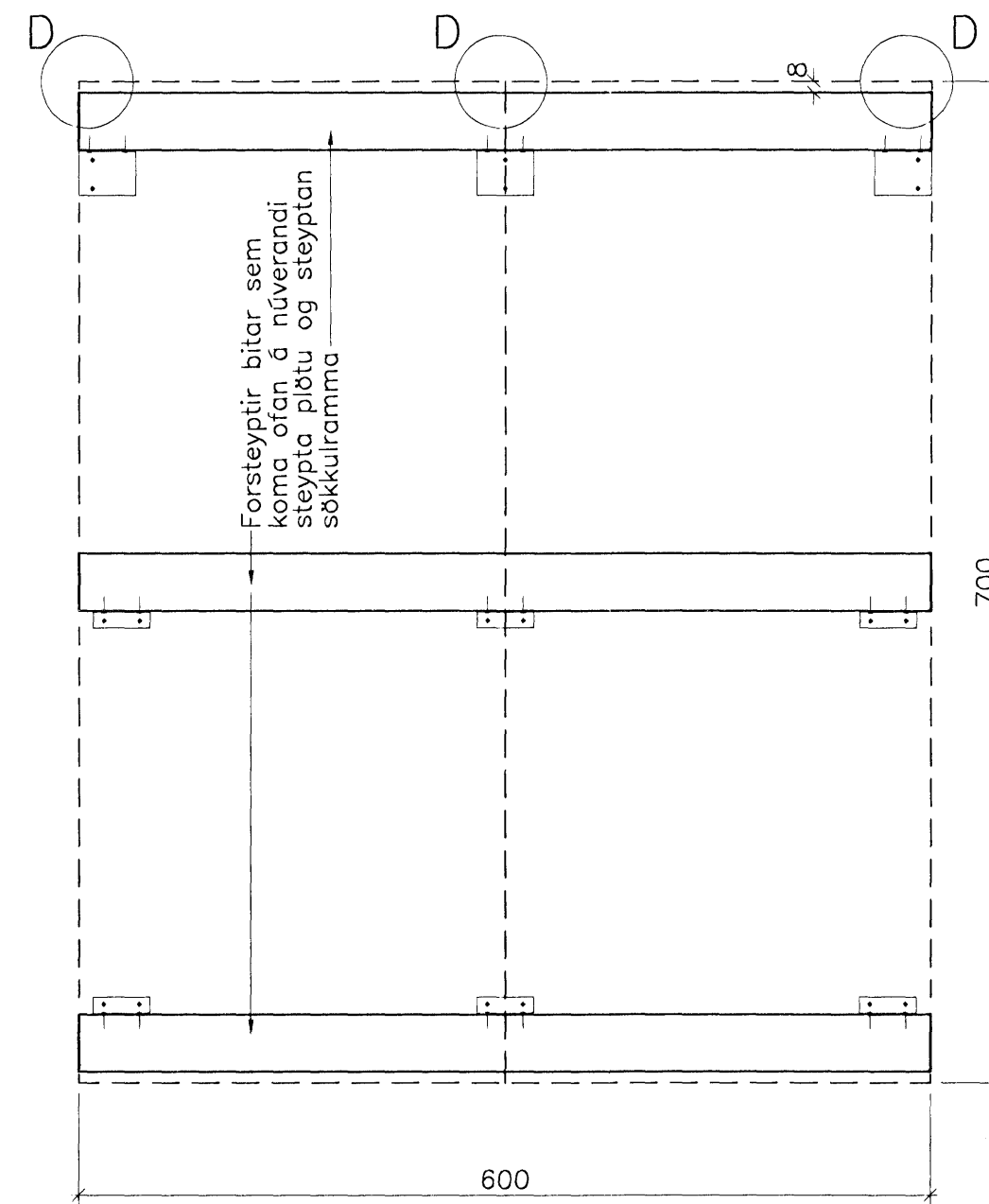

Snið í B.1.1.
1:20 L=600 cm, 3. stk.

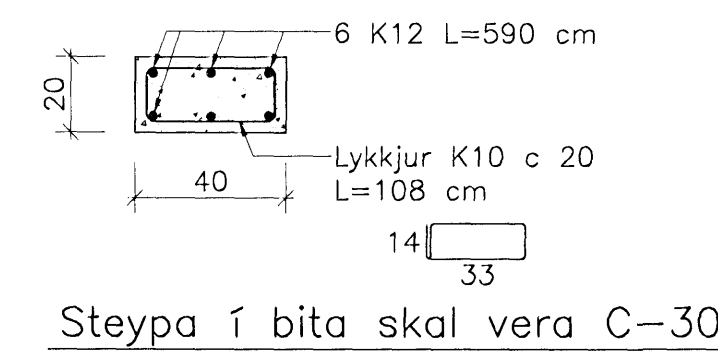

Sérmynd A
1:10 6. stk.

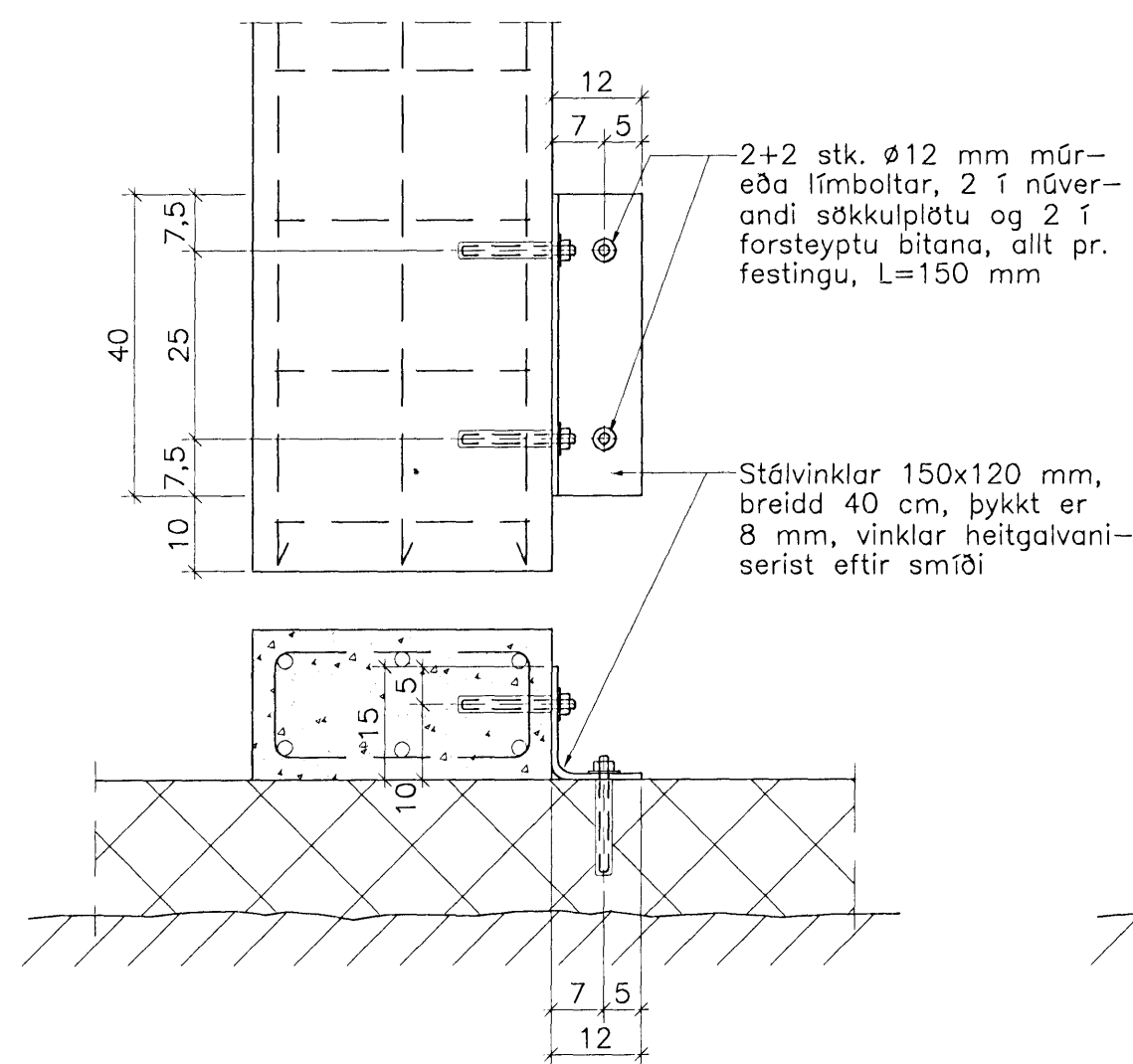

Sérmynd B
1:10 1. stk.

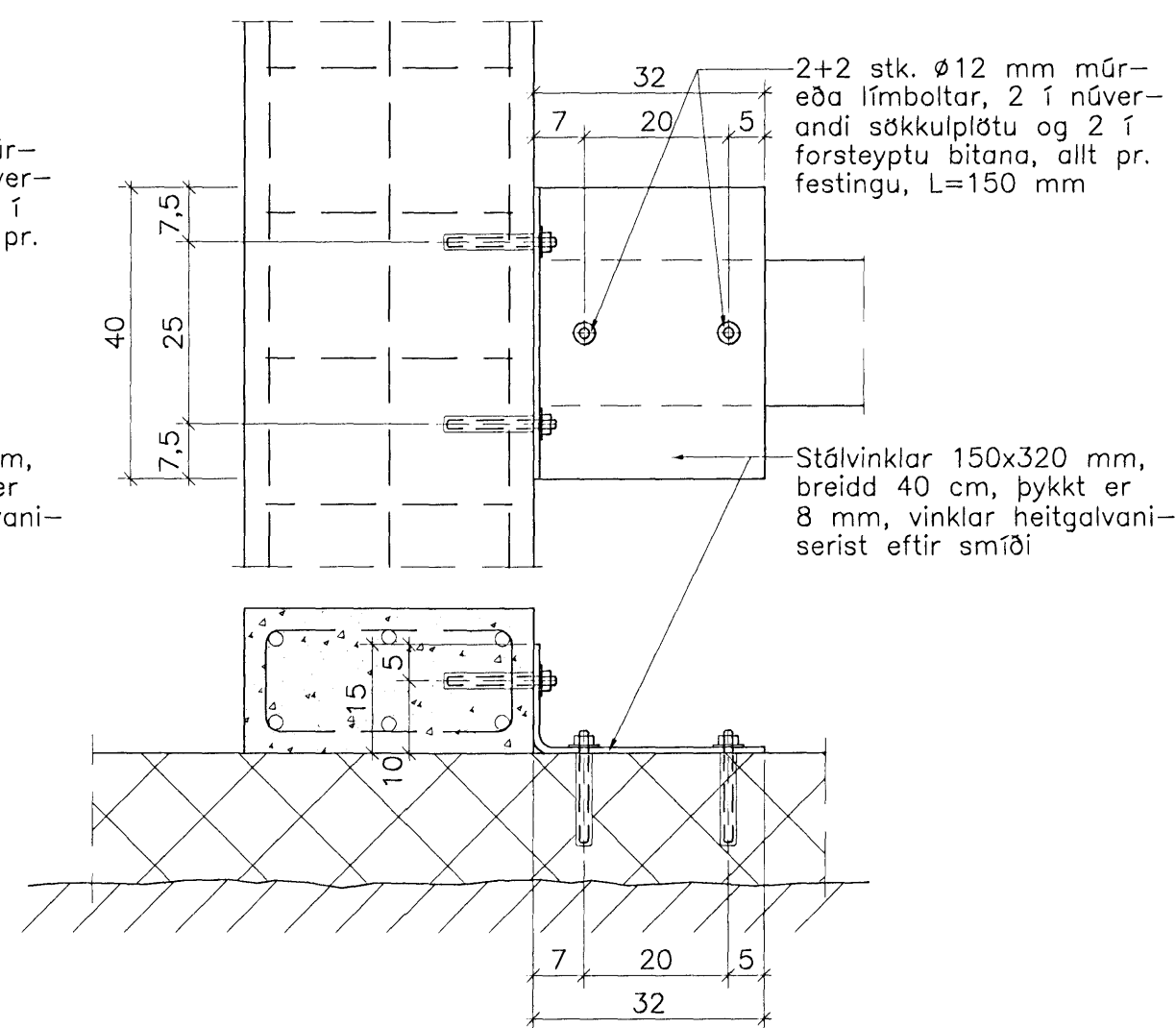

Sérmynd C
1:10 2. stk.

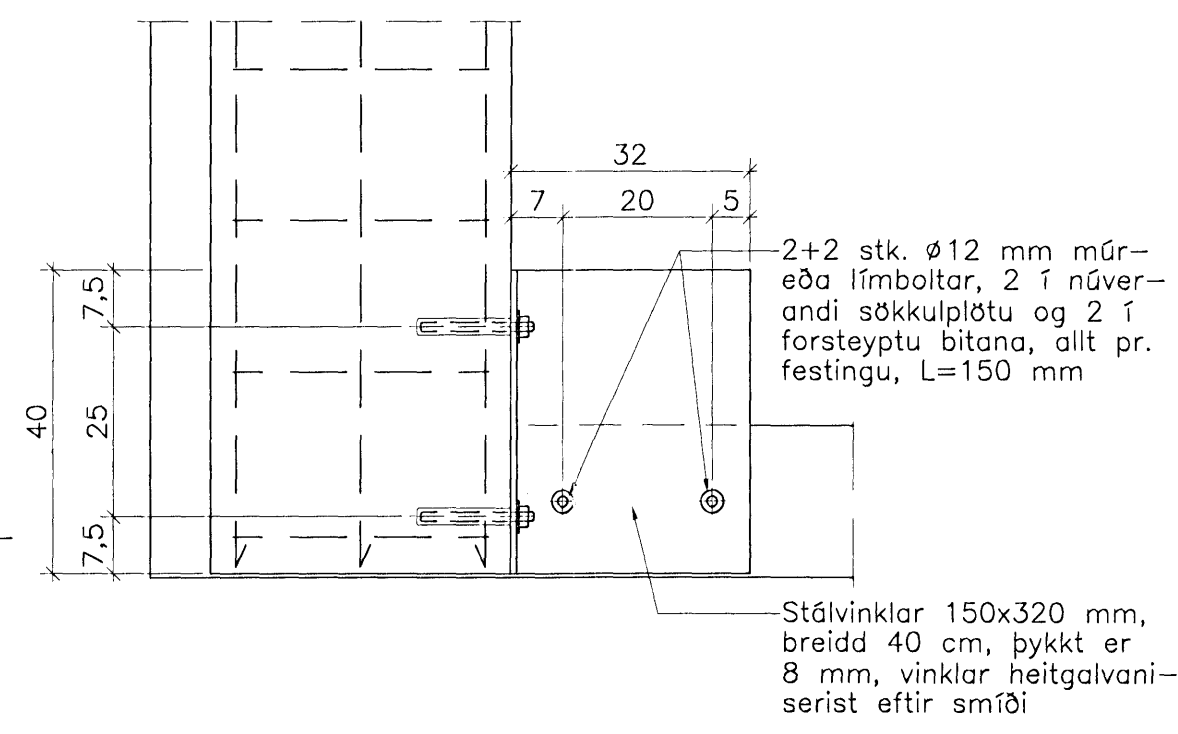

Sérmynd D
1:10 4+4. stk.

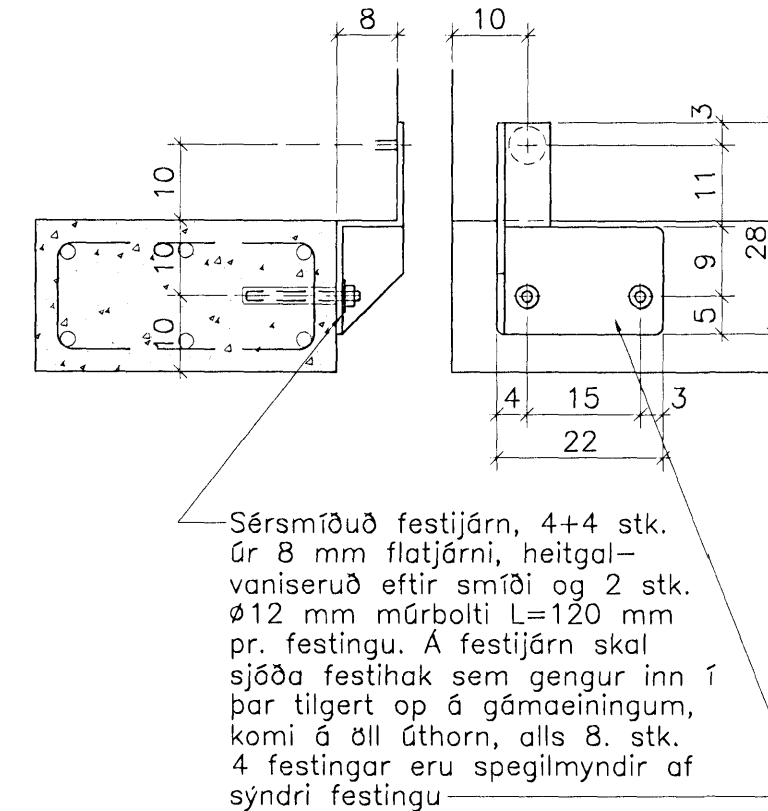

Breytingar:

TEIKNISTOFAN ÓDINSTORGI
VERKFRÆÐIÐ EHF.
TÓV
Óðingstu, 7
101 Reykjavík
Netfang: tov@to.is
Sími: 510 2200 Fax: 510 2201

Verkefni: Breiðhella 8-10 Hafnarfirði
Endurvinnslustöð Sorpu
Heiti: Járn- steypa: Starfsmannaástaða
undirstöðufestingar

Hönnun: VÍFILL ÓDDSSON kt. 101237-3629	VERKFRÆÐINGUR FVFI - FRV
Kristján S. Guðm. kt. 070254-5819	VERKFRÆÐINGUR FVFI
Gústaf Vífilsson kt. 231163-5069	VERKFRÆÐINGUR FVFI

Aritun aðgönguvarar:
[Signature] 082153-4429
M. 1:50, 1:20 og 1:10
R. K.S.G.
T. K.S.G.
Dags. júlí 2010 Nr. 1201-1-8