

230X20PLT X 230
2 X PLT8

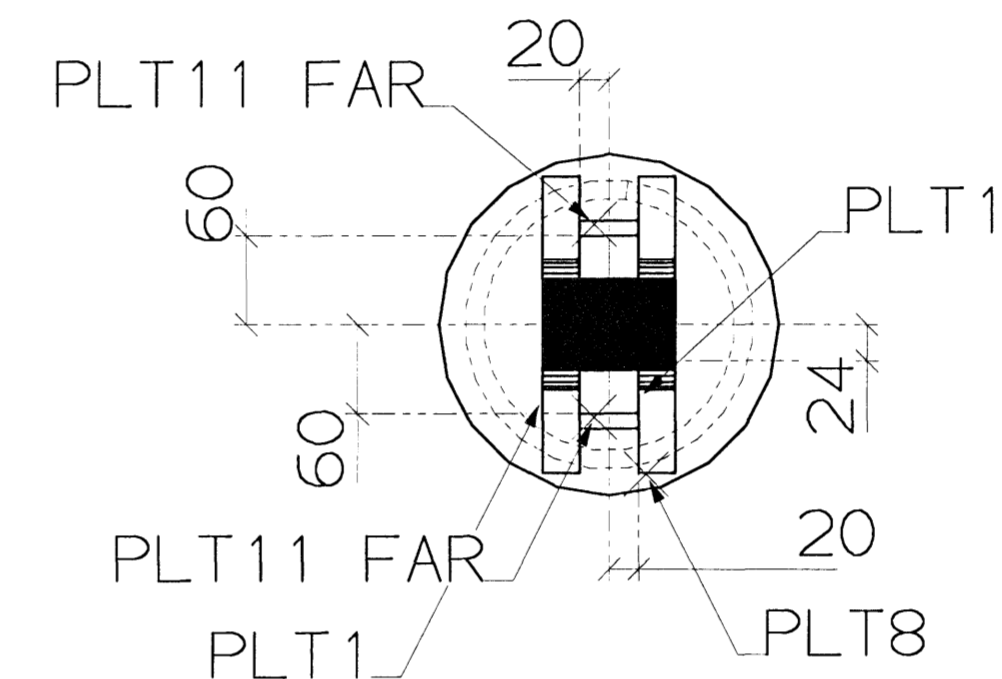

VIEW B-B

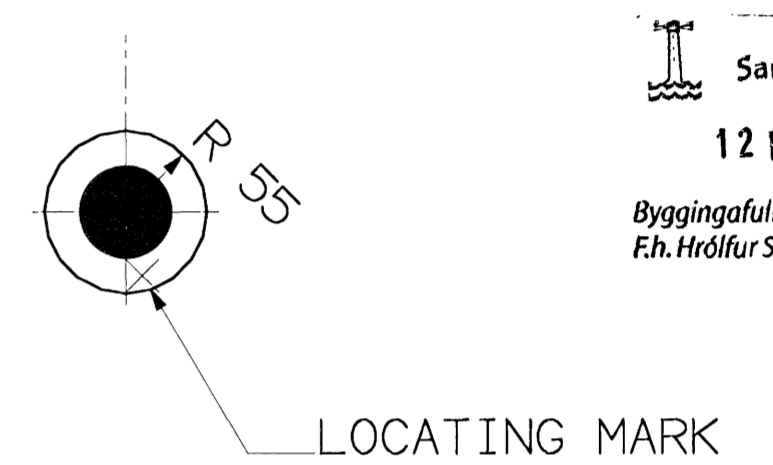

110X40PLT X 110
1 X PLT37

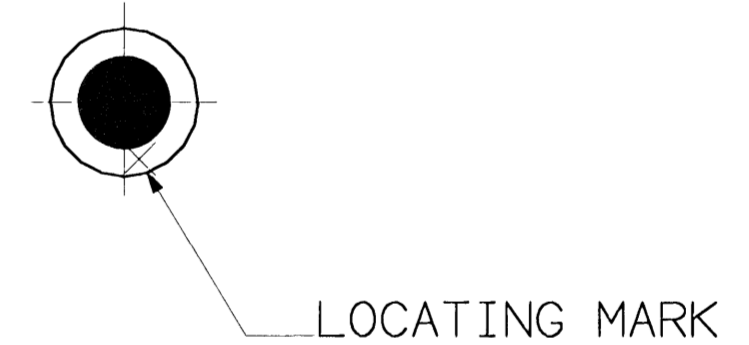

100X40PLT X 100
1 X PLT10



100X33PLT X 100
2 X PLT15

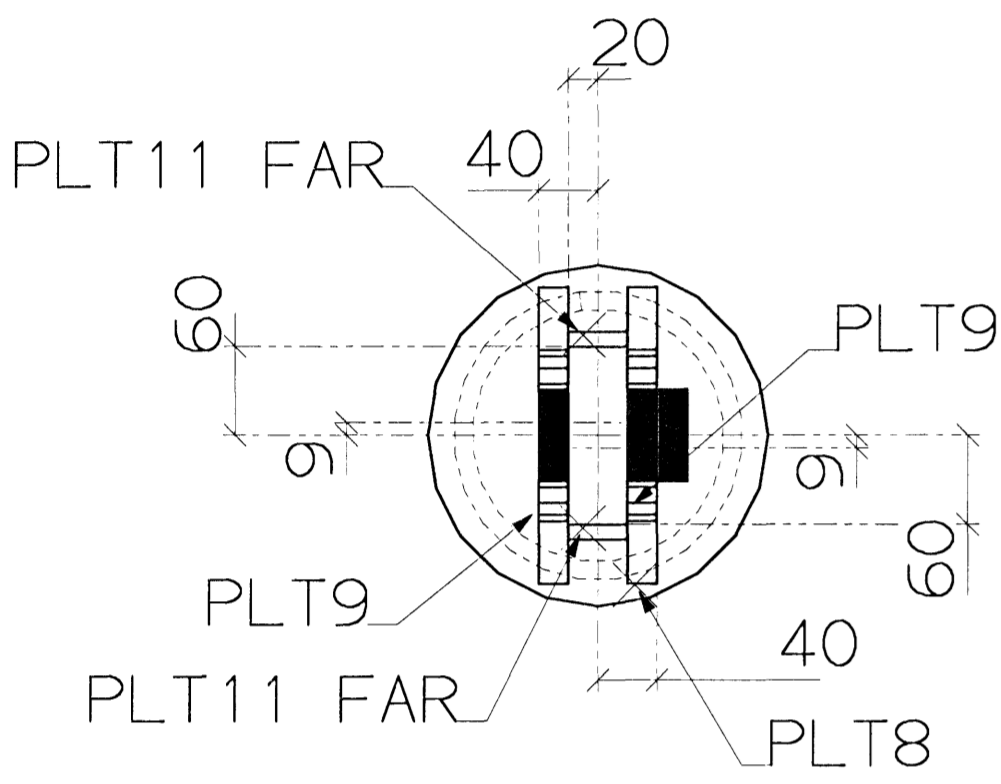

VIEW A-A



10X100PLT X 40
4 X PLT11

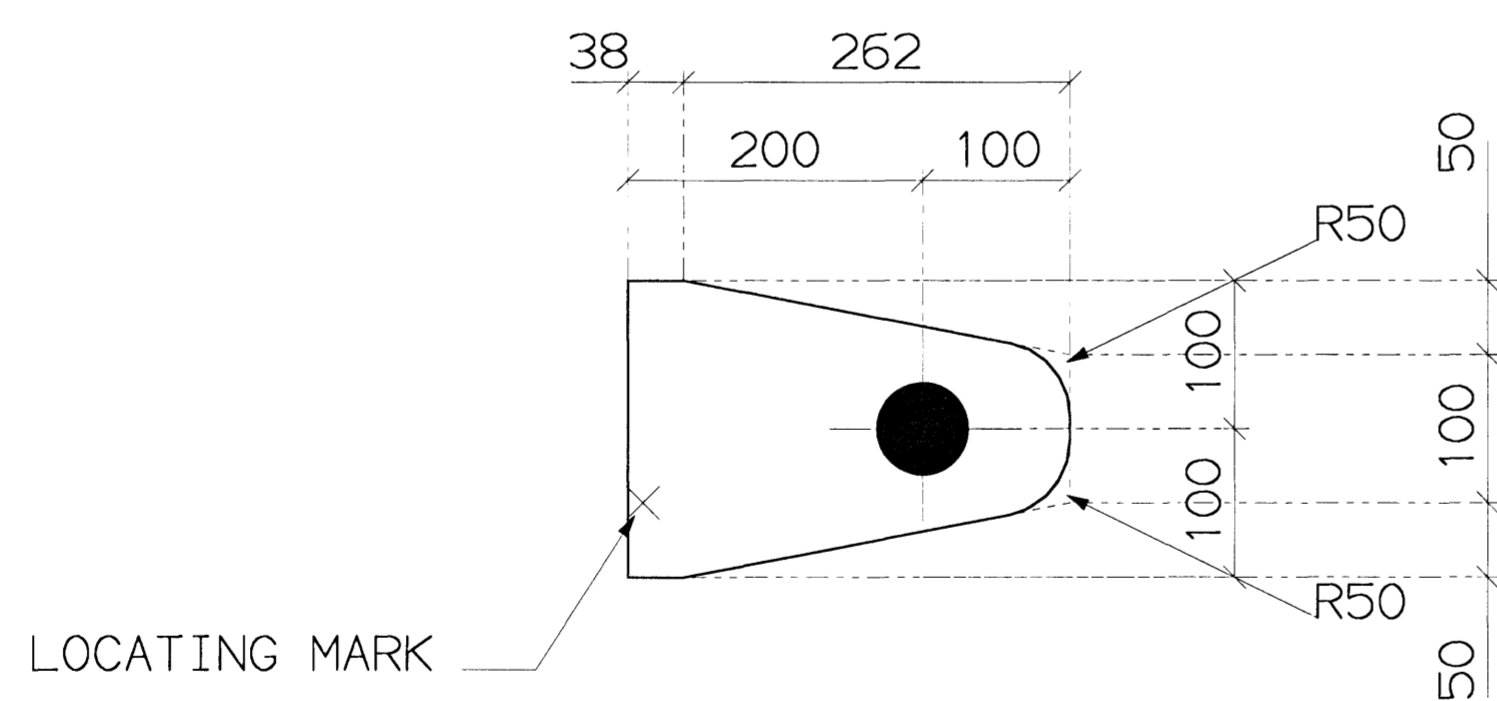

200X20FLAT X 300
2 X PLT9

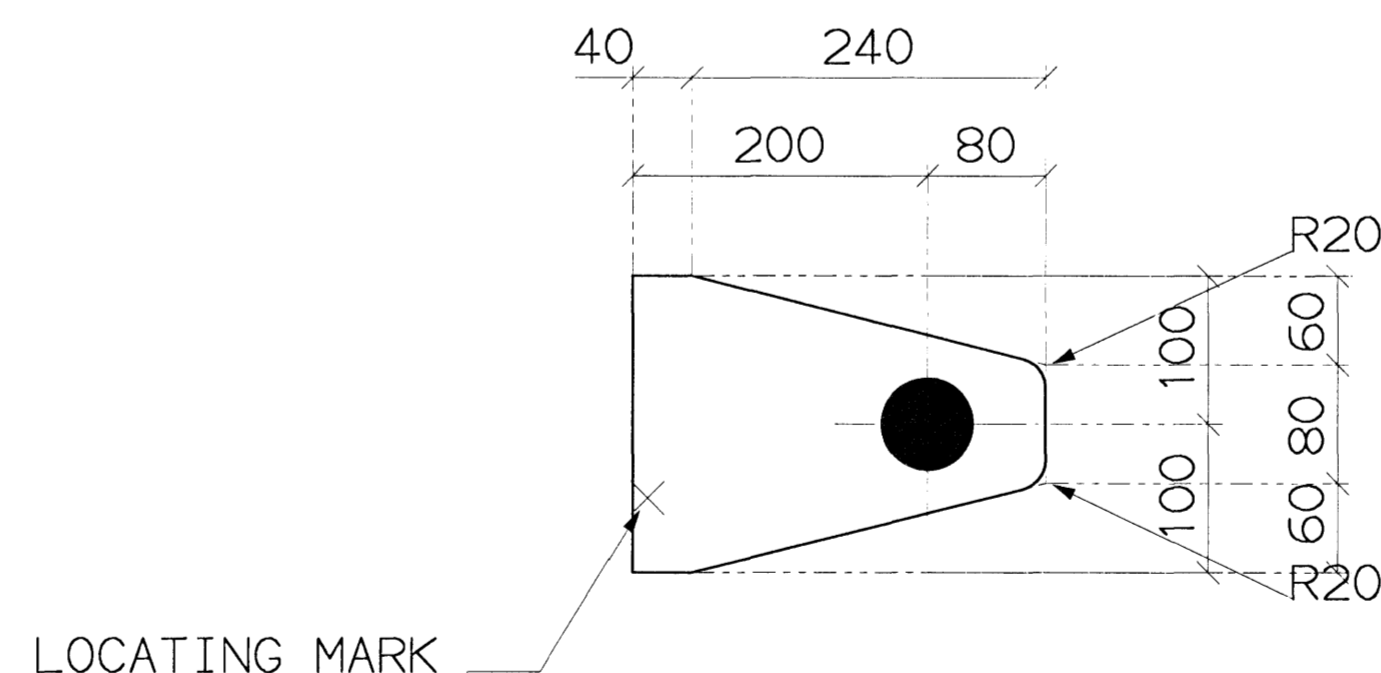

200X25FLAT X 280
2 X PLT1

SHOP MATERIAL LIST FOR 1 ASSEMBLY							
MARK	SIZE	GRADE	LENGTH MM	No	AREA M2	WEIGHT KG	
25	193.7X12.5CHS1	S235	1534	1	0.90	85.7	
PLT1	200X25FLAT	S235	280	2	0.27	22.0	
PLT8	230X20PLT	S235	230	2	0.25	16.6	
PLT9	200X20FLAT	S235	300	2	0.28	18.8	
PLT10	100X40PLT	S235	100	1	0.04	3.1	
PLT11	10X100PLT	S235	40	4	0.04	1.3	
PLT15	100X33PLT	S235	100	2	0.07	5.2	
PLT37	110X40PLT	S235	110	1	0.04	3.8	
TOTAL						1.89	156.6

BOLT LIST FOR 1 ASSEMBLY					
DIAMETER	TYPE	GRADE	GRIP LENGTH	BOLT LENGTH	No
60	X0X	10.9	201	280	1

LOCATION LIST	
GRID LOC.	GRID LOC.
1/B/3534	1/B/1494
1/E/3534	1/E/1494
1/H/3534	1/H/1494
1/K/3534	1/K/1494
1/N/3534	1/N/1494
1/O/3534	1/O/1494
1/P/3534	1/P/1494
1/Q/3534	1/Q/1494
1/R/3534	1/R/1494
1/S/3534	1/S/1494

RADIAL CUT DIMS GIVEN TO INTERSECTION POINTS

Samþykkt þann

12 MAY 2009

Byggingafulltrúinn / Hafnarfiré
Fh. Hrólfur S. Gunnlaugsson

10 REQUIRED AS DRAWN MARKED 25

NOTES:

ALL WELDS FOR FOLLOW SECTIONS a>1.09t
CONT. FILLED UNO, WHERE t IS THE WALL
THICKNESS OF THE SECTION, OR FULL
PENETRATION BUTT WELD

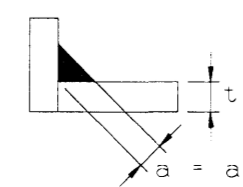

a = all noted weld sizes

GENERAL NOTES:

ALL WELDS 6 mm CONT. FILLET UNO
ALL HOLES 63 mm DIAM UNO
TOTAL WEIGHT 156.6 kg.
STEEL GRADE S235

CLIENT
BYKO

PROJECT
KAPLAKRIKI

TITLE

DRAWN MLM 01/04/08
CHECKED JRA 5/5 '09

VGK HÖNNUN
GRENSASVEGI 1 108 REYKJAVIK, SÍM: 422 3000 FAX: 422 3001
VEFRANG www.vgk.honnun.is NETFANG vgk.honnun@vgk.honnun.is

STRUCAD

REV	BY	DATE	DETAILS

SCALE	JOB No	DWG No.	REV
NTS	7.120.257	25	