

SHOP MATERIAL LIST FOR 1 ASSEMBLY							
MARK	STOCK	GRADE	LENGTH MM	No	SURFACE M2	WEIGHT KG	
PLT2	257X20PLT	S235	560	1	0.20	13.6	
PLT3	257X20PLT	S235	560	1	0.20	13.6	
PLT4	50X10PLT	S235	82	2	0.02	0.6	
PLT7	384X20PLT	S235	678	2	0.54	36.8	
1-MMA	139.7X10CHS1	S235	11184	1	4.70	357.9	
4-MMA	139.7X6.3CHS1	S235	1566	1	0.63	32.4	
6-MMA	139.7X6.3CHS1	S235	1594	1	0.65	33.0	
7-MMA	139.7X6.3CHS1	S235	2024	1	0.82	41.9	
8-MMA	139.7X6.3CHS1	S235	2093	1	0.85	43.3	
9-MMA	114.3X6.3CHS1	S235	1976	1	0.65	33.2	
10-MMA	114.3X6.3CHS1	S235	300	1	0.11	5.1	
PLT13	155X10PLT	S235	155	1	0.04	1.5	
PLT14	10X82PLT	S235	120	2	0.05	1.5	
PLT16	240X10FLAT	S235	240	1	0.10	3.5	
PLT18	50XBPLT	S235	80	32	0.32	8.0	
PLT21	100XBFLAT	S235	100	8	0.14	3.8	
PLT22	100XBFLAT	S235	100	8	0.14	3.8	
PLT31	100XBFLAT	S235	100	5	0.09	2.4	
PLT32	100XBFLAT	S235	100	5	0.09	2.4	
PLT38	100XBFLAT	S235	67	1	0.01	0.4	
PLT39	100XBFLAT	S235	67	1	0.01	0.4	
PLT41	100XBFLAT	S235	54	1	0.01	0.3	
PLT42	100XBFLAT	S235	54	1	0.01	0.3	
PLT50	50XBPLT	S235	87	1	0.01	0.2	
PLT51	50XBPLT	S235	80	1	0.01	0.2	
PLT52	155XBPLT	S235	155	2	0.08	2.3	
10-MMA	114.3X6.3CHS1	S235	1603	1	0.55	26.9	
11-MMA	114.3X6.3CHS1	S235	1799	1	0.60	30.2	
12-MMA	114.3X6.3CHS1	S235	1527	1	0.50	25.7	
15-MMA	48.3X5CHS1	S235	1208	1	0.17	6.5	
16-MMA	48.3X5CHS1	S235	1395	1	0.20	7.4	
17-MMA	48.3X5CHS1	S235	1375	1	0.19	7.3	
18-MMA	48.3X5CHS1	S235	1197	1	0.17	6.4	
19-MMA	48.3X5CHS1	S235	1019	1	0.15	5.4	
20-MMA	48.3X5CHS1	S235	841	1	0.12	4.5	
23-MMA	114.3X6.3CHS1	S235	1759	1	0.59	29.6	
37-MMA	139.7X10CHS1	S235	5712	1	2.40	182.8	
59-MMA	139.7X10CHS1	S235	4624	1	1.94	148.0	
89-MMA	139.7X6.3CHS1	S235	1407	1	0.57	29.1	
TOTAL						18.64	1152.4

SHOP MATERIAL LIST FOR 5 ASSEMBLIES							
MARK	STOCK	GRADE	LENGTH MM	No	SURFACE M2	WEIGHT KG	
PLT2	257X20PLT	S235	560	5	1.00	67.8	
PLT3	257X20PLT	S235	560	5	1.00	67.8	
PLT4	50X10PLT	S235	82	10	0.11	3.2	
PLT7	384X20PLT	S235	678	10	2.68	184.2	
1-MMA	139.7X10CHS1	S235	11184	5	23.50	1789.4	
4-MMA	139.7X6.3CHS1	S235	1566	5	3.16	162.1	
6-MMA	139.7X6.3CHS1	S235	1594	5	3.23	165.0	
7-MMA	139.7X6.3CHS1	S235	2024	5	4.12	209.5	
8-MMA	139.7X6.3CHS1	S235	2093	5	4.25	216.6	
9-MMA	114.3X6.3CHS1	S235	1976	5	3.25	166.0	
10-MMA	114.3X6.3CHS1	S235	300	5	0.53	25.3	
PLT13	155X10PLT	S235	155	5	0.21	7.3	
PLT14	10X82PLT	S235	120	10	0.24	7.7	
PLT16	240X10FLAT	S235	240	5	0.48	17.5	
PLT18	50XBPLT	S235	80	160	1.61	40.2	
PLT21	100XBFLAT	S235	100	40	0.72	19.1	
PLT22	100XBFLAT	S235	100	40	0.72	19.1	
PLT31	100XBFLAT	S235	100	25	0.45	12.0	
PLT32	100XBFLAT	S235	100	25	0.45	12.0	
PLT38	100XBFLAT	S235	67	5	0.07	1.9	
PLT39	100XBFLAT	S235	67	5	0.07	1.9	
PLT41	100XBFLAT	S235	54	5	0.06	1.6	
PLT42	100XBFLAT	S235	54	5	0.06	1.6	
PLT50	50XBPLT	S235	87	5	0.05	1.1	
PLT51	50XBPLT	S235	80	5	0.05	1.1	
PLT52	155XBPLT	S235	155	10	0.41	11.7	
10-MMA	114.3X6.3CHS1	S235	1603	5	2.73	134.7	
11-MMA	114.3X6.3CHS1	S235	1799	5	2.98	151.1	
12-MMA	114.3X6.3CHS1	S235	1527	5	2.50	128.3	
15-MMA	48.3X5CHS1	S235	1208	5	0.85	32.3	
16-MMA	48.3X5CHS1	S235	1395	5	0.99	37.2	
17-MMA	48.3X5CHS1	S235	1375	5	0.97	36.7	
18-MMA	48.3X5CHS1	S235	1197	5	0.85	32.0	
19-MMA	48.3X5CHS1	S235	1019	5	0.72	27.2	
20-MMA	48.3X5CHS1	S235	841	5	0.60	22.4	
23-MMA	114.3X6.3CHS1	S235	1759	5	2.95	147.8	
37-MMA	139.7X10CHS1	S235	5712	5	12.00	914.0	
59-MMA	139.7X10CHS1	S235	4624	5	9.71	739.9	
89-MMA	139.7X6.3CHS1	S235	1407	5	2.86	145.6	
TOTAL						93.22	5761.9

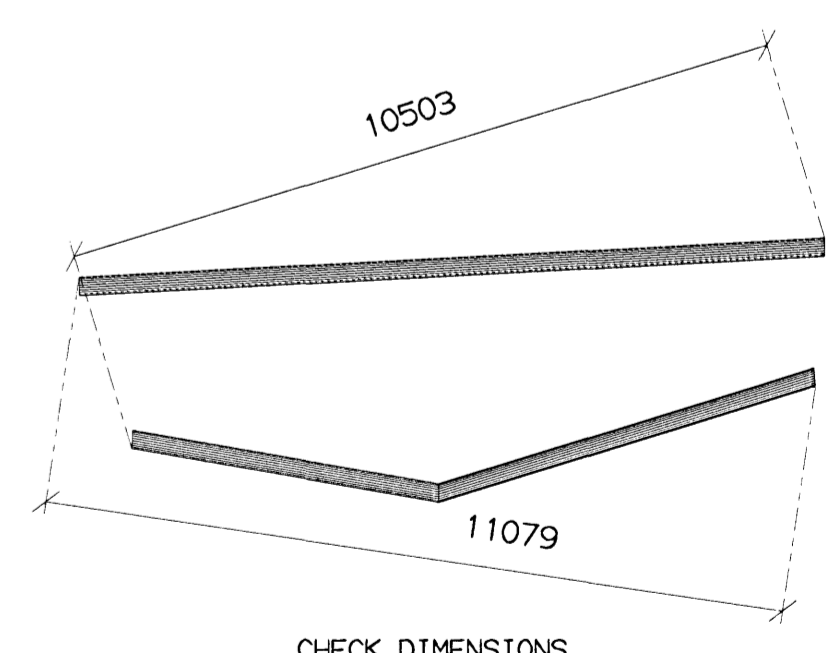
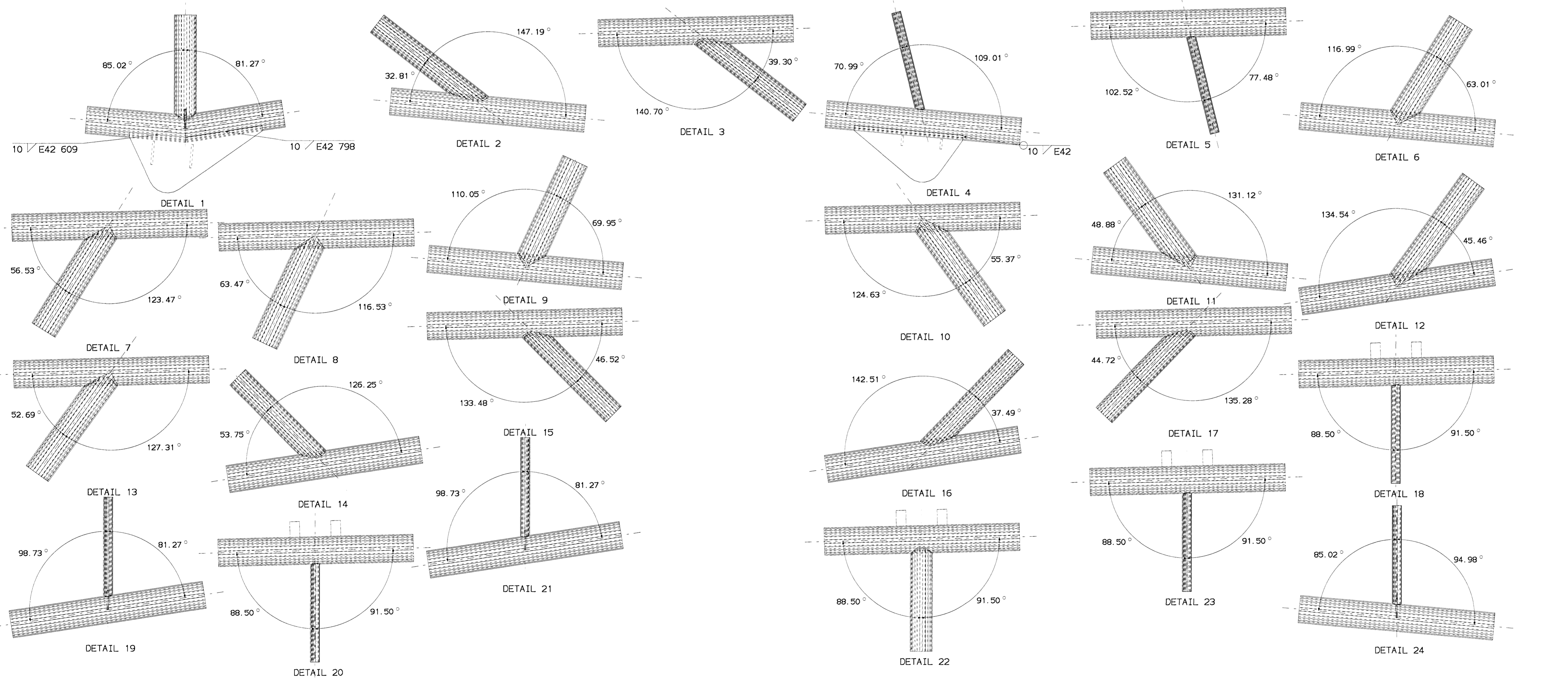

Samþykkt þann  
 12 MAY 2009  
 Byggingafræðingur / Hafnarfræðingur  
 F.h. Hrólfur S. Gunnlaugsson

*[Signature]*  
 Kr. 110457-2789  
 STRUCAD

5 REQUIRED AS DRAWN MARKED MMA-12

REV	BY	DATE	DETAILS

**NOTES:**

ALL WELDS FOR HOLLOW SECTIONS >1.09t CONT. FILLED UNO, WHERE t IS THE WALL THICKNESS OF THE SECTION, OR FULL PENETRATION BUTT WELD.

*[Weld symbol diagram]*  
 a = all noted weld sizes.

**GENERAL NOTES:**

ALL WELDS 6 mm CONT. FILLET UNO  
 ALL HOLES 22 mm DIAM UNO  
 TOTAL WEIGHT 1152.4 kg.  
 STEEL GRADE S235

CLIENT	BYKO
PROJECT	KAPLAKRIKI
TITLE	

DRAWN	MLM	01/04/08
CHECKED	J.P.A.	5/5 '09

<p>GREINISVEGUR 1 108 REYKJAVÍK SÍM: 422 3000 FAX: 422 3001          VEFANG: www.vgk.honnun.is NETFANG: vgonn@vgk.honnun.is</p>			
SCALE	JOB No	DWG No.	REV
NTS	7.120.257	MMA-12	