

SHOP MATERIAL LIST FOR 1 ASSEMBLY						
MARK	STOCK	GRADE	LENGTH MM	No	SURFACE M2	WEIGHT KG
PLT6	50XBPLT	S235	67	1	0.01	0.2
PLT12	50XBPLT	S235	69	1	0.01	0.2
PLT16	240X10FLAT	S235	240	5	0.48	17.5
PLT18	50XBPLT	S235	80	12	0.12	3.0
PLT21	100XBFLAT	S235	100	5	0.09	2.4
PLT22	100XBFLAT	S235	100	5	0.09	2.4
PLT52	155XBPLT	S235	155	2	0.08	2.3
13-MMA	114. 3X6. 3CHS1	S235	1559	1	0.50	26.2
14-MMA	48. 3X5CHS1	S235	1110	1	0.14	5.9
21-MMA	48. 3X5CHS1	S235	662	1	0.09	3.5
22-MMA	48. 3X5CHS1	S235	484	1	0.07	2.6
24-MMA	48. 3X5CHS1	S235	1227	1	0.16	6.6
38-MMA	139. 7X10CHS1	S235	3995	1	1.68	127.8
87-MMA	139. 7X10CHS1	S235	3639	1	1.53	116.5
TOTAL					4.68	303.1

SHOP MATERIAL LIST FOR 5 ASSEMBLIES						
MARK	STOCK	GRADE	LENGTH MM	No	SURFACE M2	WEIGHT KG
PLT6	50XBPLT	S235	67	5	0.04	0.9
PLT12	50XBPLT	S235	69	5	0.04	0.9
PLT16	240X10FLAT	S235	240	5	0.48	17.5
PLT18	50XBPLT	S235	80	60	0.60	15.1
PLT21	100XBFLAT	S235	100	25	0.45	11.9
PLT22	100XBFLAT	S235	100	25	0.45	11.9
PLT52	155XBPLT	S235	155	10	0.41	11.7
13-MMA	114. 3X6. 3CHS1	S235	1559	5	2.50	130.9
14-MMA	48. 3X5CHS1	S235	1110	5	0.72	29.6
21-MMA	48. 3X5CHS1	S235	662	5	0.47	17.7
22-MMA	48. 3X5CHS1	S235	484	5	0.34	12.9
24-MMA	48. 3X5CHS1	S235	1227	5	0.82	32.8
38-MMA	139. 7X10CHS1	S235	3995	5	8.41	639.2
87-MMA	139. 7X10CHS1	S235	3639	5	7.66	582.3
TOTAL					23.39	1515.4

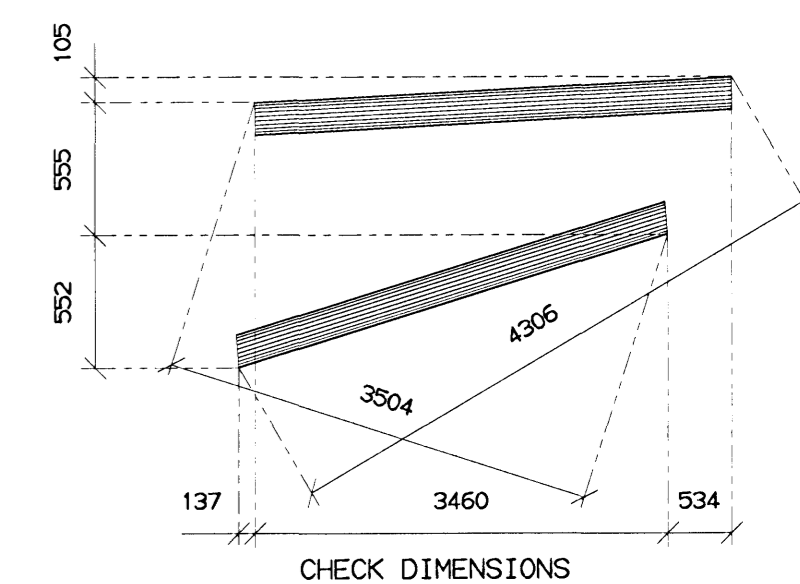

Samþykkt þann
 12 MAY 2009
 Byggingafulltrúinn í Hamarró,
 Fh. Hrólfur S. Gunnlaugsson

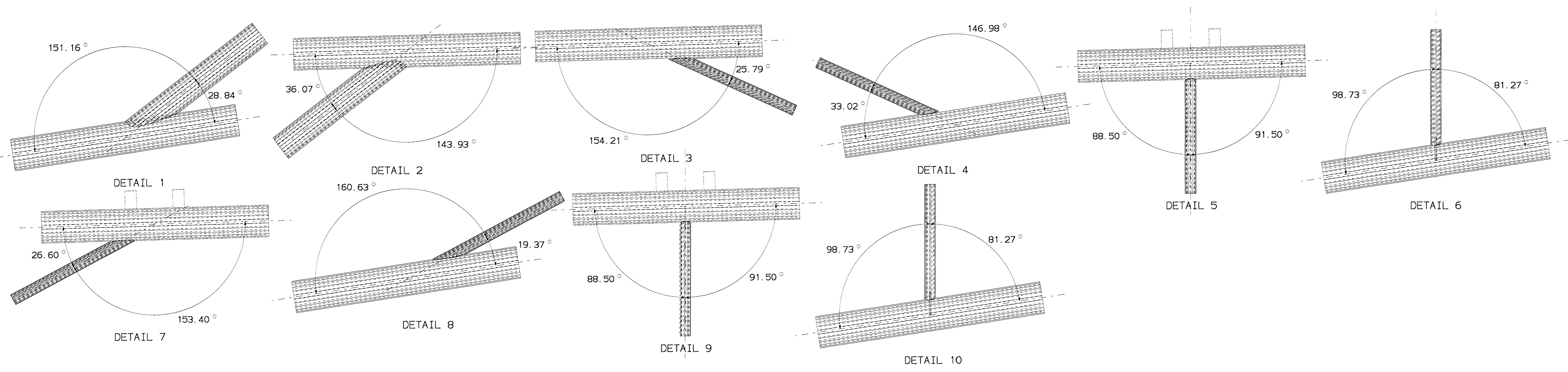

5 REQUIRED AS DRAWN MARKED MMA-6

REV	BY	DATE	DETAILS

NOTES:
 ALL WELDS FOR HOLLOW SECTIONS $a > 1.0t$ CONT. FILLED UNO, WHERE t IS THE WALL THICKNESS OF THE SECTION, OR FULL PENETRATION BUTT WELD

 a = all noted weld sizes

GENERAL NOTES:
 ALL WELDS 6 mm UNO
 ALL HOLES 22 mm DIAM UNO
 TOTAL WEIGHT 303.1 kg.
 STEEL GRADE S235

CLIENT BYKO	DRAWN MLM	01/04/08
PROJECT KAPLAKRIKI	CHECKED IFC	5/5 '07
TITLE		

SCALE	JOB No	DWG No.	REV
NTS	7. 120. 257	MMA-6	

VGK HÖNNUN
 GRENÁSVEGI 1 108 REYKJAVÍK ÍSÍ 422 3000 FAX 422 3001
 VEFANG www.vgk.honnun.is NEIFANG vgk.honnun@vgk.honnun.is