

Veggir 2. hæð, Plata yfir 2. hæð, Grunnmynd, 1:50

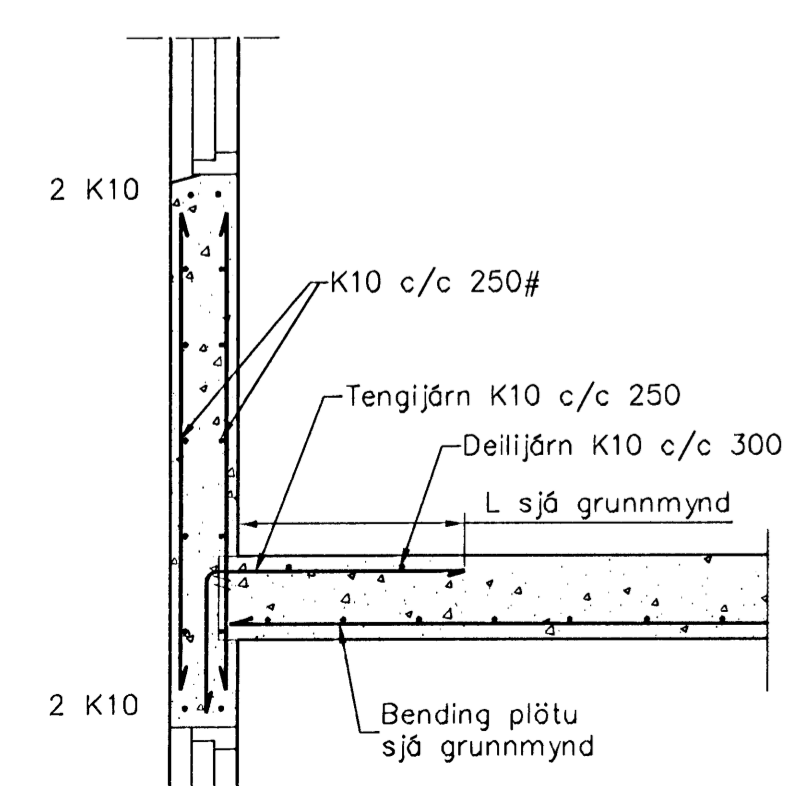

Snið 1
1:20 1-05

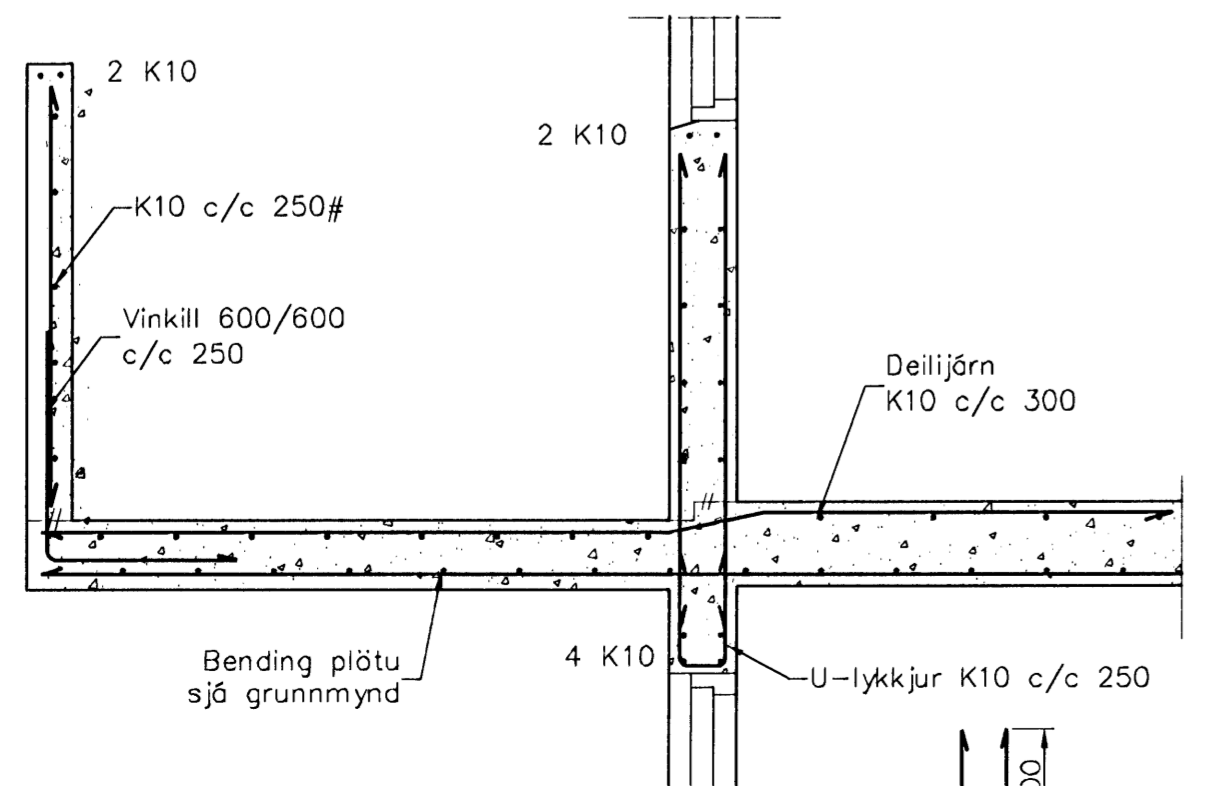

Snið 2
1:20 1-05

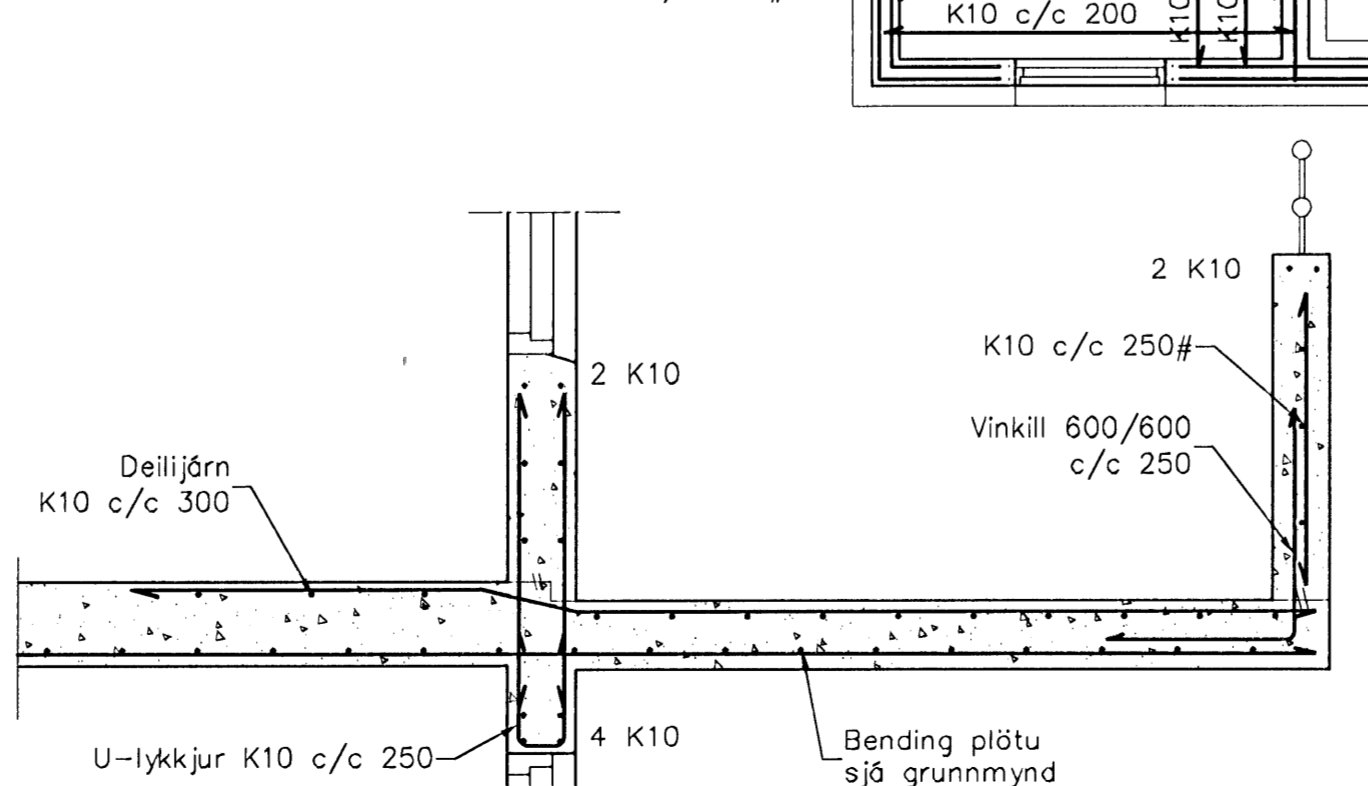

Snið 3
1:20 1-05

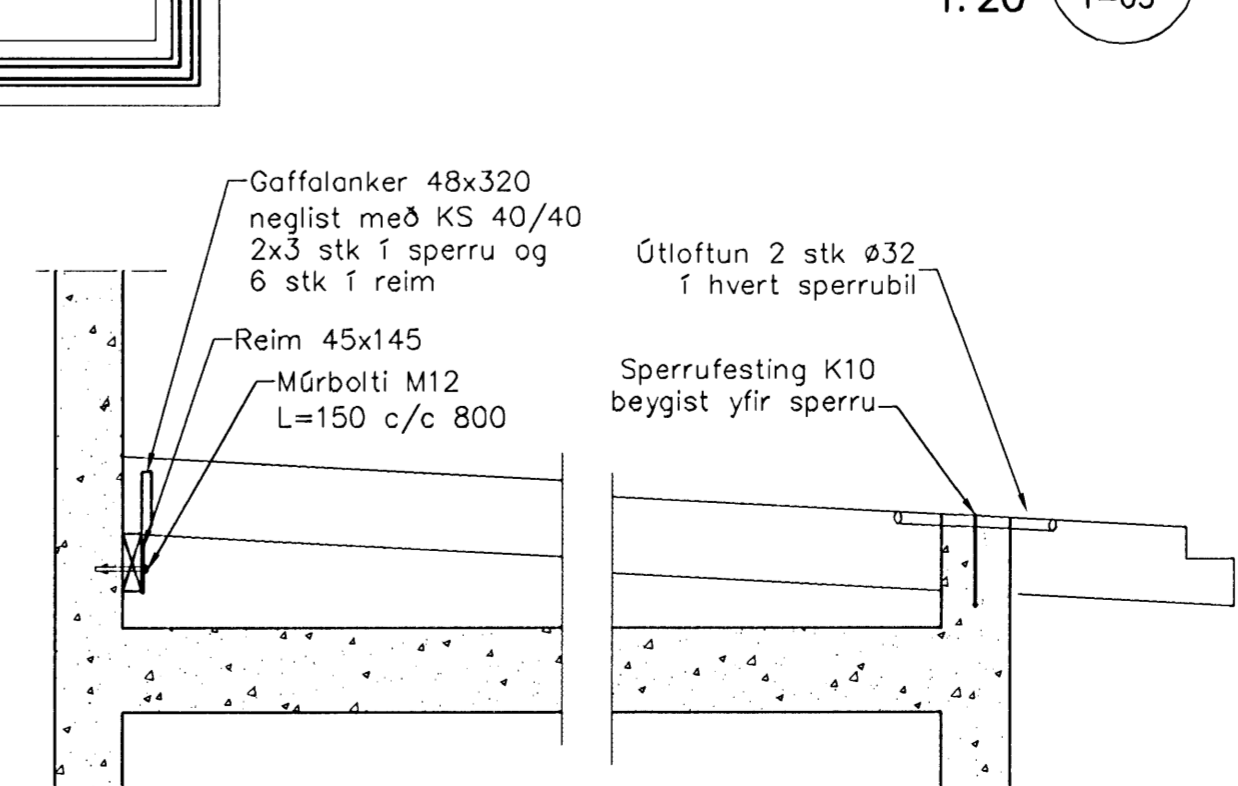

Snið 4
1:20 1-05

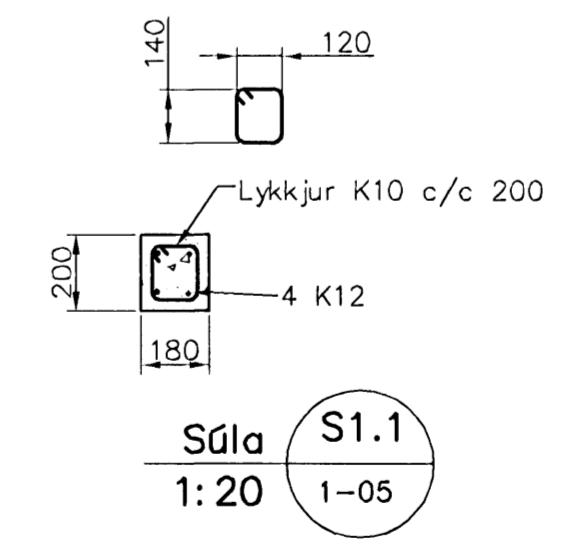

Samþykkt þann
07 JAN 2009
Byggingaráhrúnn í Hafnarfirði
F.H. Hrólfur S. Gunnlaugsson

Skýringar

Almennar skýringar sjá blað 00-01
Stærð
Brotþolsflokkur: C25/28 samkv. ENV 206 (250)
Vatnsementtala: skól vera minni en 0,55
Lofmagn: 5-7%
Sigmál: 60-80 mm
Álag á plötur: 5,5 kN/m²
Eiginbygnd: 1,0 kN/m²
Léttir máliveggir: 1,5 kN/m²
Notaðlag á plötur og svalir: 3,0 kN/2

Útgáfa	Breyting	Dagsetning	Hannað
Sveinbjörn Hinriksson Byggingatæknifræðingur Kl. 100851-2529 Brekkgötu 8 Hafnarfirði Sími: 556-4008, 981-6851 Netfang: sveinh@netnet.is		Staður Klukkuvellir 7 Hafnarfirði	
Hannað/Teiknað		Skýring Plata yfir 2. hæð	
Kvarði 1:50 1:20	Dagsetning 4.01.09	Verkr. 04-08	Teikn.nr. 1-05