

CROSS SECTION SCHEDULE (LEFT FROM RIDGE)					
BOLT SCHEDULE			FLANGE BRACE		
CONN	QTY	SIZE	LENGTH	MARK	PART MARK
(B1)	4	M30	900	(P3)	07-1005
(K2)	10	M36	120	(P5)	07-1006
(S3)	8	M27	110	(P7)	07-1001
(S4)	10	M27	110	(P9)	07-1002
				(P10)	07-1003
				(P11)	07-1004
				(P12)	07-1004

CROSS SECTION SCHEDULE (RIGHT FROM RIDGE)					
BOLT SCHEDULE			FLANGE BRACE		
CONN	QTY	SIZE	LENGTH	MARK	PART MARK
(S4)	10	M27	110	(P2)	07-0313
(S5)	10	M36	120	(P4)	07-1000
				(P6)	07-1001
				(P8)	07-1002
				(P9)	07-1003
				(P10)	07-1004
				(P11)	07-1004

CROSS SECTION SCHEDULE (LEFT FROM RIDGE) FOR AREA#02					
BOLT SCHEDULE			FLANGE BRACE		
CONN	QTY	SIZE	LENGTH	MARK	PART MARK
(B1)	6	M36	1000	(P3)	07-2004
(K1)	10	M36	120	(P5)	07-2005
(S1)	10	M27	90	(P7)	07-2006
(S2)	8	M27	90	(P9)	07-2007
				(P10)	07-2008
				(P11)	07-2009
				(P12)	07-2009

CROSS SECTION SCHEDULE (RIGHT FROM RIDGE) FOR AREA#02					
BOLT SCHEDULE			FLANGE BRACE		
CONN	QTY	SIZE	LENGTH	MARK	PART MARK
(B1)	4	M36	1000	(P3)	07-2004
(K1)	10	M36	120	(P5)	07-2005
(S1)	10	M27	90	(P7)	07-2006
				(P9)	07-2007
				(P10)	07-2008
				(P11)	07-2009
				(P12)	07-2009

IMPORTANT NOTES

- High strength bolts (HSB) are galvanized while mild steel bolts (MSB) are electro plated (yellow chromate conversion). These bolts are marked on the heads so that they can be easily identified.
- The correct type of bolts must be used as called for on the details. Using wrong type of bolts may cause building failure at the erector's responsibility.
- Continuous machine submerged arc weldings (S.A.W.) meet the applicable requirements of the American Welding Society (A.W.S.) D1.1-2004.
- Web-to-flange welds are single side fillet welds in accordance with the ninth edition of the AISC Table J2.4 Page 5-67 unless noted otherwise.
- Web-butt welds are complete penetration using flux back-up (16mm plate max.)
- Flange butt welds are on both sides with copper back-up. Flanges 19mm or thicker are beveled prior to assembly.
- Gusset plates for flange braces are welded on both sides of the column and rafter, however flange braces are required at one side (unless noted otherwise). For aesthetic reasons, it is preferable to install them all at the same side of column and rafter. The side chosen depending on erection sequence.

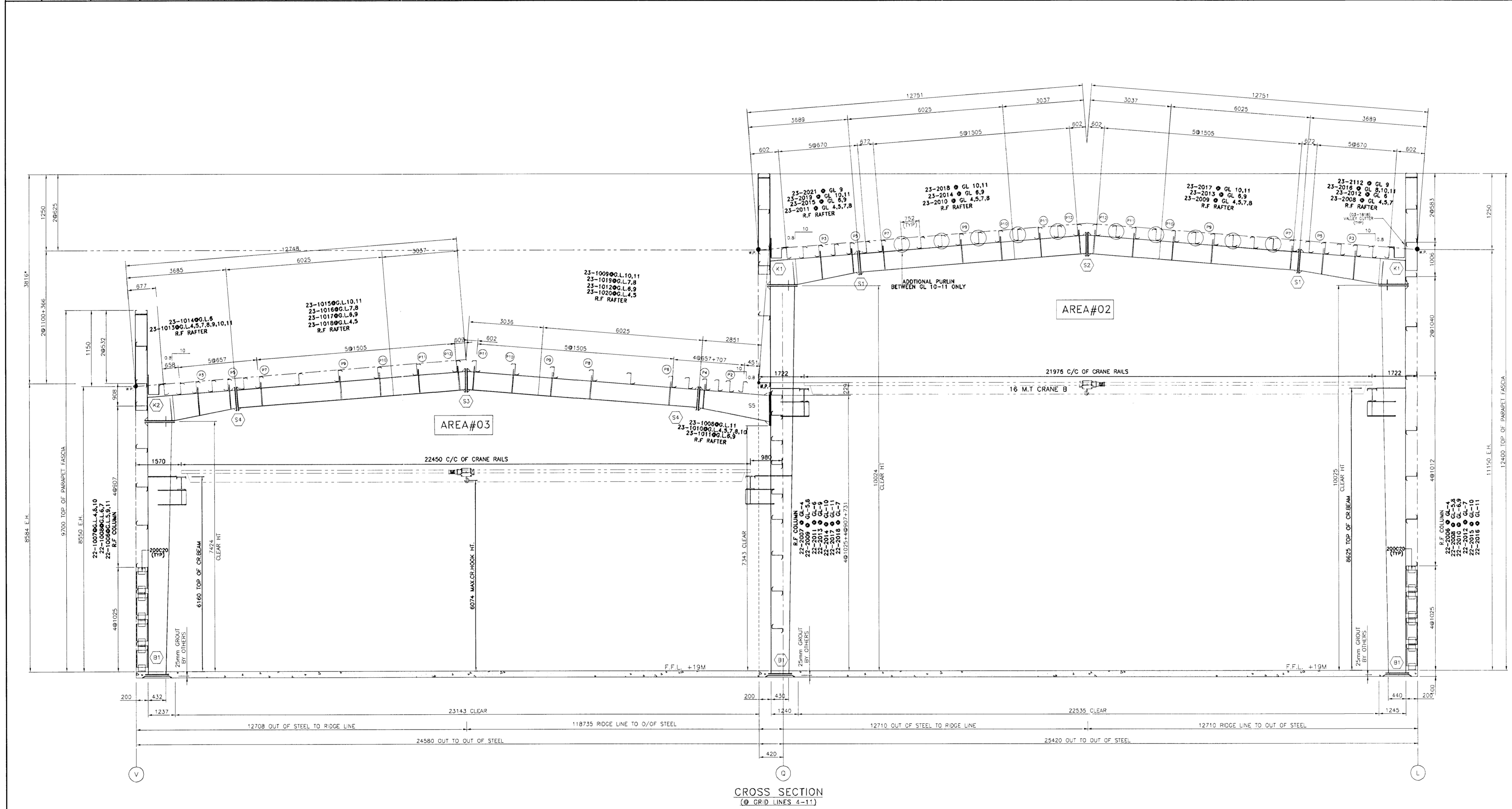

Samþykkt þann
24 JUNI 2008
Byggingarfulltrúinn í Hafnafirði
F. H. Hrólfur S. Gunnlaugsson

ASK
26. maí 2008
VST Verkfæðistofa
Sigurðar Thoroddsón hf.
Eh. VST hf. Hildur Hansson 150916-4929

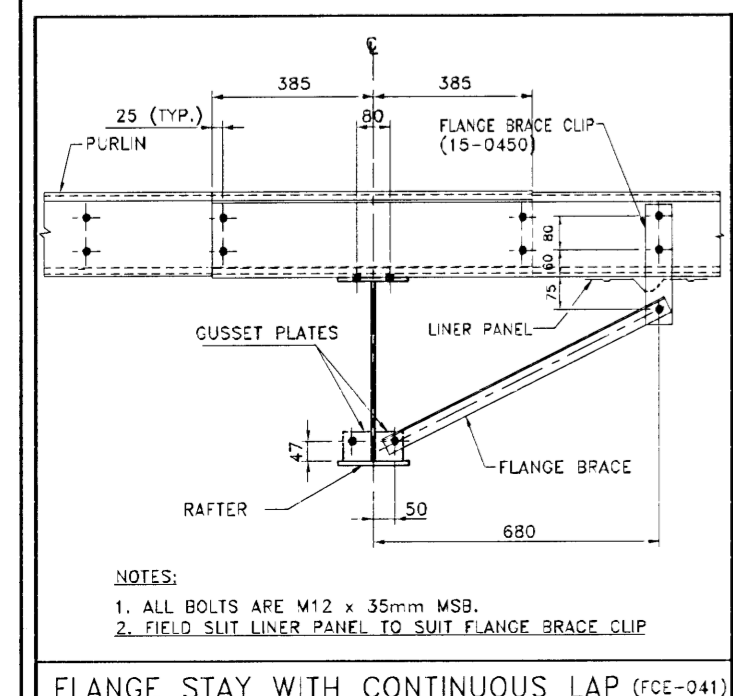

NO.	DATE	DESCRIPTION	DRN	CHK	DSN
2	20.05.2008	ISSUED FOR CONSTRUCTION	NSK	TPS	IPC
1	24.11.2007	RE-ISSUED FOR APPROVAL	MGK	VRA	IPC
0	25.10.2007	ISSUED FOR APPROVAL	KRT	VRA	IPC

ZS JOB NO. : V7-D567		BUILDING NO. : 01
PROJECT NAME : HEDINN HOUSE		
CUSTOMER : HEDINN		
JOBSITE LOCATION : HAFNAFIRDI, ICELAND		
DRAWING TITLE : CROSS SECTION @ GL-4-11		DRAWING NO. : E08