

JARNBENDING VEGGJA

ÚTVEGGIR
Lárétt: k10 c/c 20
Lóórétt: k10 c/c 30

INNVEGGIR
Lárétt: k8 c/c 30
Lóórétt: k8 c/c 30

Glugga-gat

2K12

2K12

I kringum öll glugga og hurðargöt komi 2k12 sem gangi minnst 50 cm útfyrir gatið
I alla veggenda komi 2k12 lóórétt

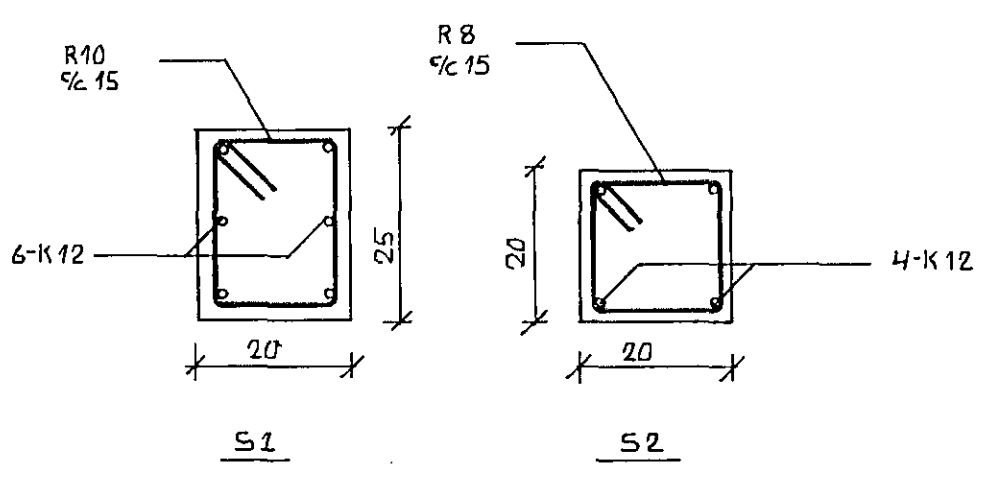
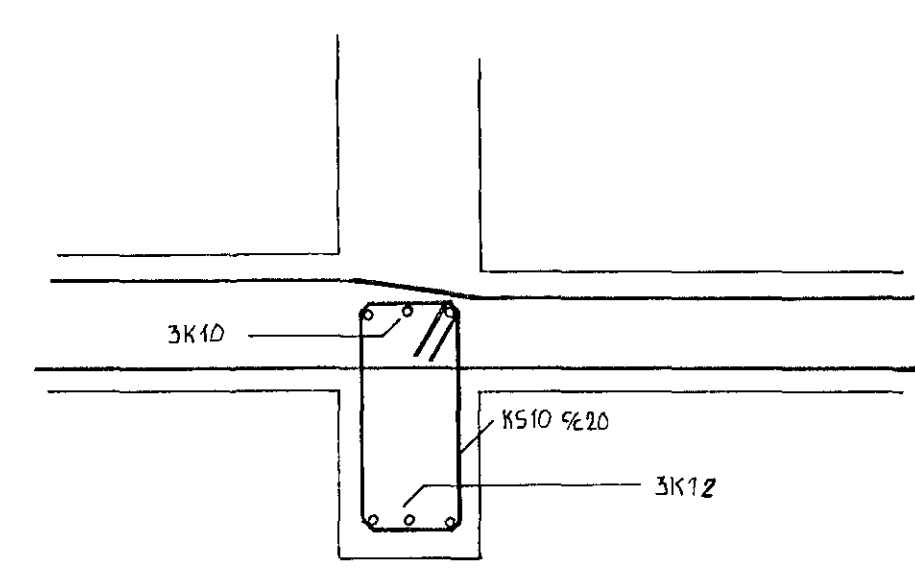
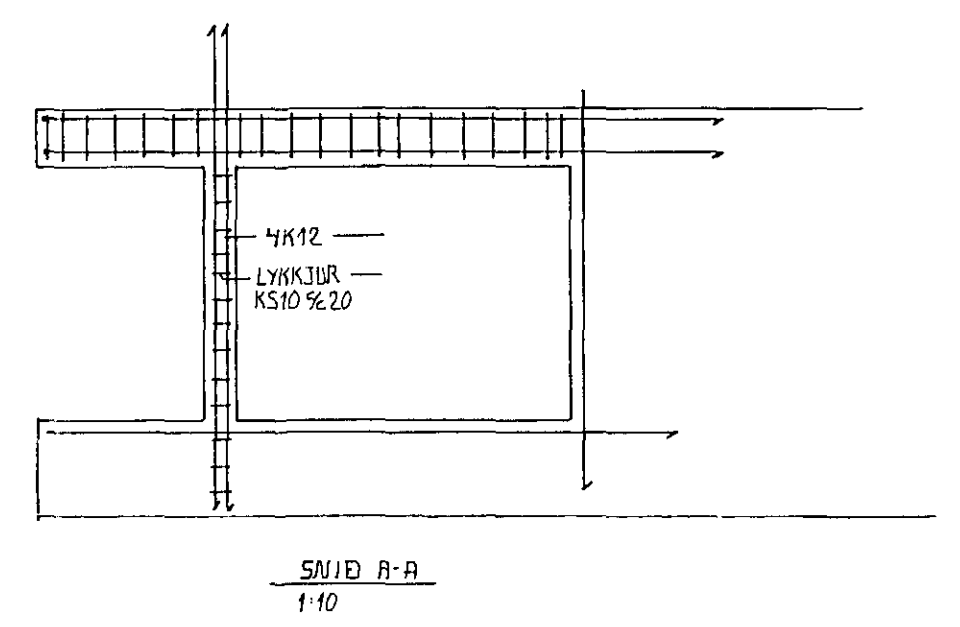
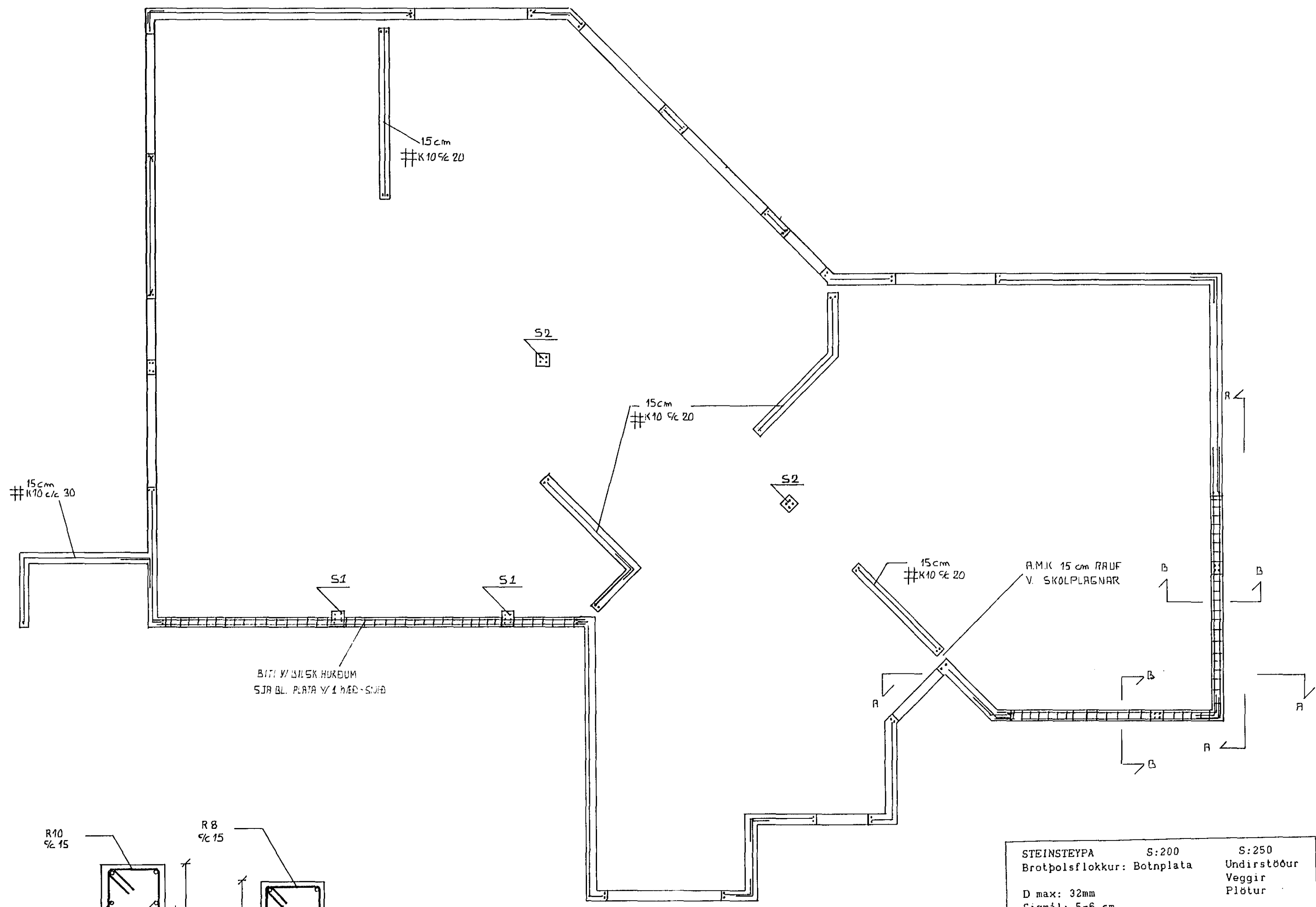

STEINSTEYPA S:200 S:250
Brotþölsflokkur: Botnplata Undirstöður
Veggir Plötur
D max: 32mm
Sigmál: 5-6 cm
Loftinnihald: 5-6 % Sementsmagn: 2300kg/m³
V/S.tala: ≤ 0.55

BENDISTÁL
Bendistál skal vera í samræmi við
Íslenskan staðal IST 10

Slétt stál ST 37 skriðmörk = 240 N/mm²
Kambstál KS 40 skriðmörk = 400 N/mm²



BREYTT MARI '90 EV.

L/EIJKJARBERG 25 HAFNARFIRÐI	DAB5. AGÚST 89 MKV 1:50 1:10
VEGGIR 1 HÆÐ	HANNAÐ: EV TEIKNAD: EV
EYJÓLFUR VALEGRÐSSON BYGGINGA- OG VÆÐINGARFRÉÐINGUR	LAUFVANGI 12 SÍMI 54793