

Grunnmynd 1/50

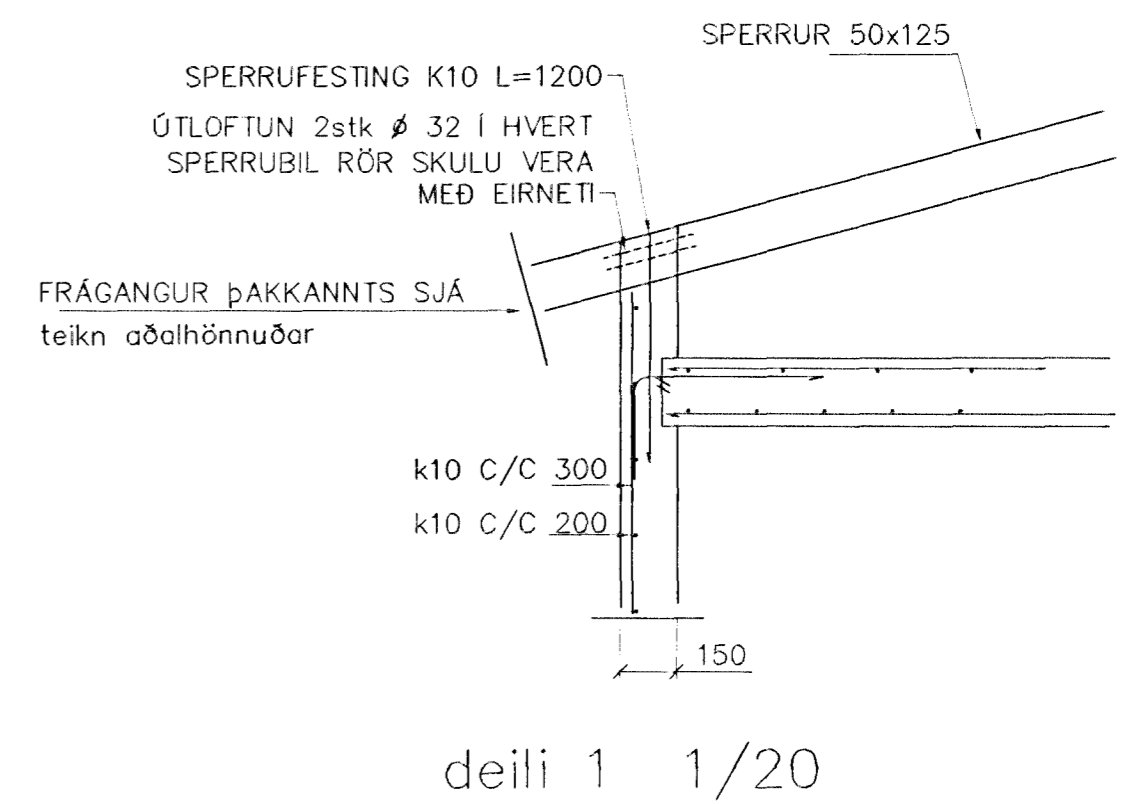

deili 1 1/20

SKÝRINGAR

ALMENNAR SKÝRINGAR SJÁ BL. 1-01
 STEYPA S-250, SEMENTINNIHALD = 300kg/M
 STEYPUHULA Í ÚTVEGGJUM = 30mm
 STEYPUHULA Í PLÖTU = 20mm
 BENDISTÁL Ks410

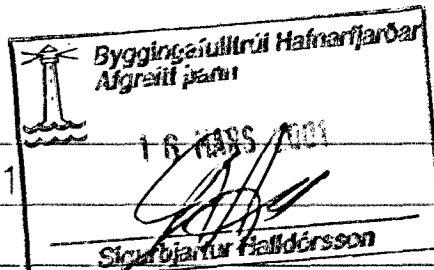
Br.	Dags.	Eðli breytinga	Sign
FAGRABERG 12 HAFNARFIRÐI			
BENDING VEGGJA 2 HÆÐAR BENDING PLÖTU YFIR 2 HÆÐ			
MKV. 1:50 1:20			
 Byggingaútlitir Hafnarfjarðar Algrætt þannir			
DAGS. mars 2001			
VERK NR. 2103			
TEIKN. NR. 1-03			
HANNAD SIG. ÞORLEIFSS. KT. 241148-3009			
TEIKNAD			
YFIRFARIÐ			
TEKNIÞJÓNUSTA SIGURÐAR ÞORLEIFSSONAR ehf STRANDGÓTU 11 220 HAFNARFIRÐI Sími 555-4255 FAX 565-2875 E-mail taeknihjonusta@islandia.is kt: 440693-2539			

BENDING VEGGJA
 Útveggjir einföld grind í útbrún
 Lárétt K10 c/c 200
 Löðrétt K10 c/c 300
 Milliveggir einföld grind í miðjan vegg
 K10 c/c 250#

1/1
 15/10/01
 lrb