

SNID A
MKV. 1:20 011

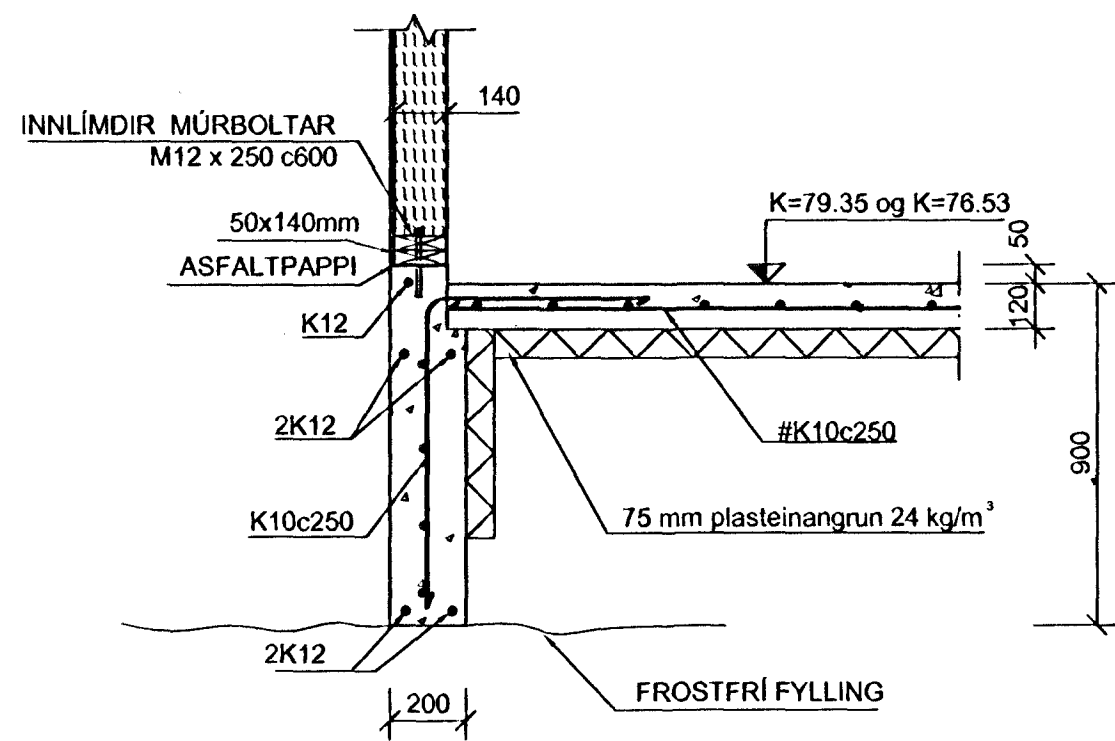

SNID B
MKV. 1:20 011

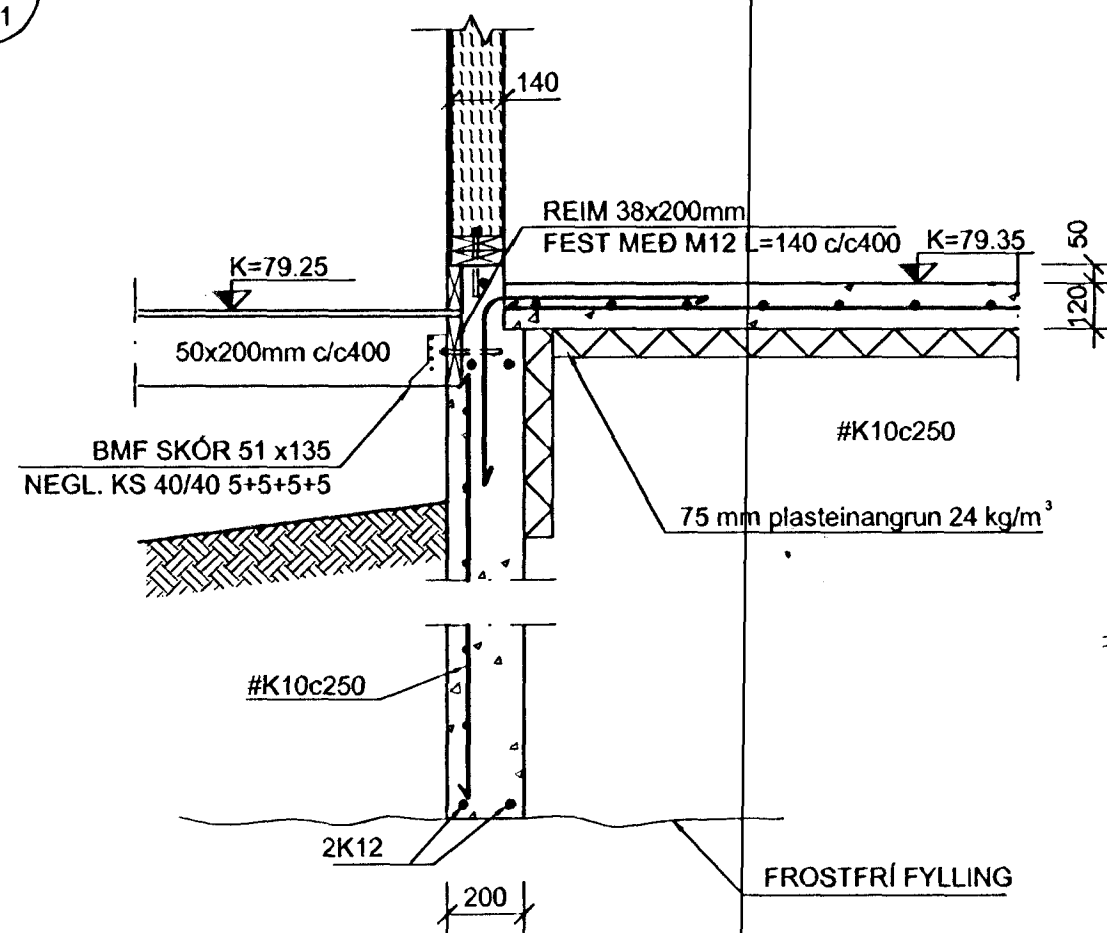

SNID C
MKV. 1:20 011

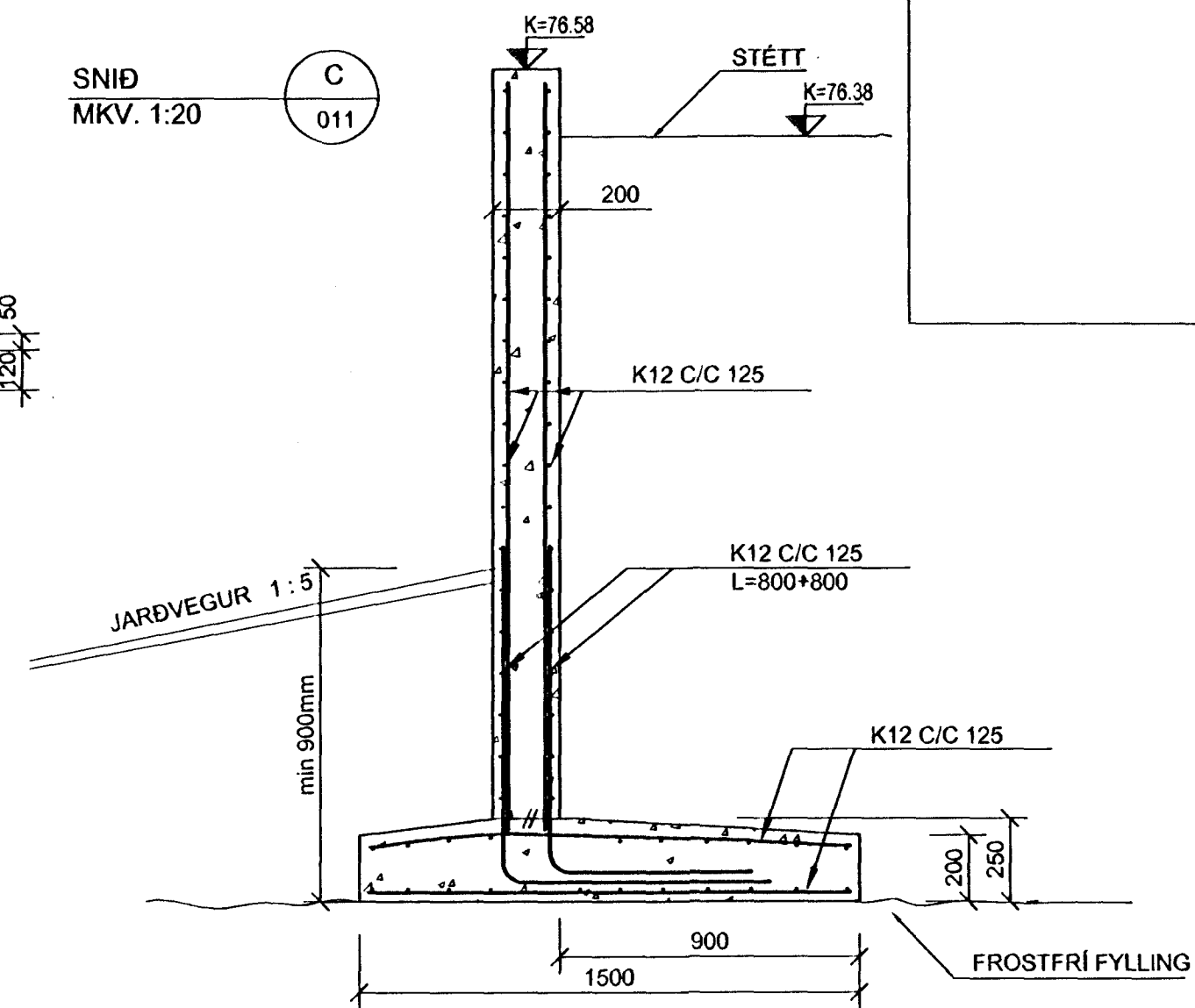

SNID D
MKV. 1:20 011

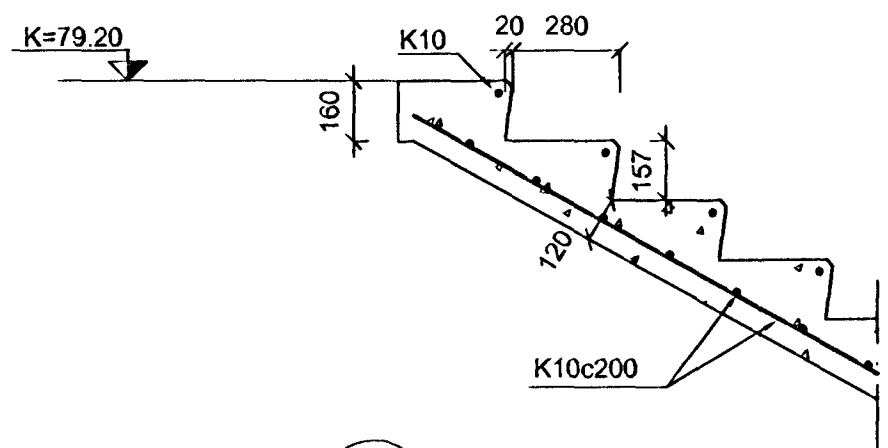

SNID I
MKV. 1:20 011

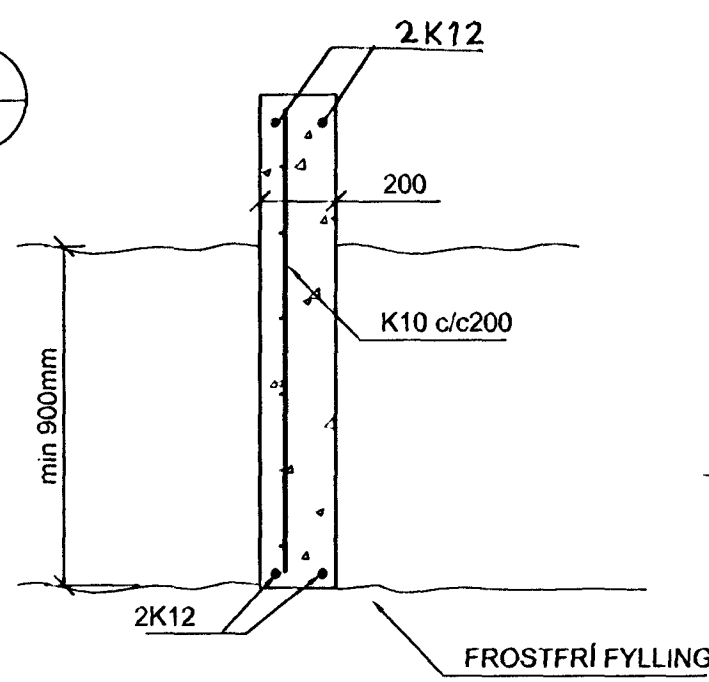

SNID E
MKV. 1:20 011

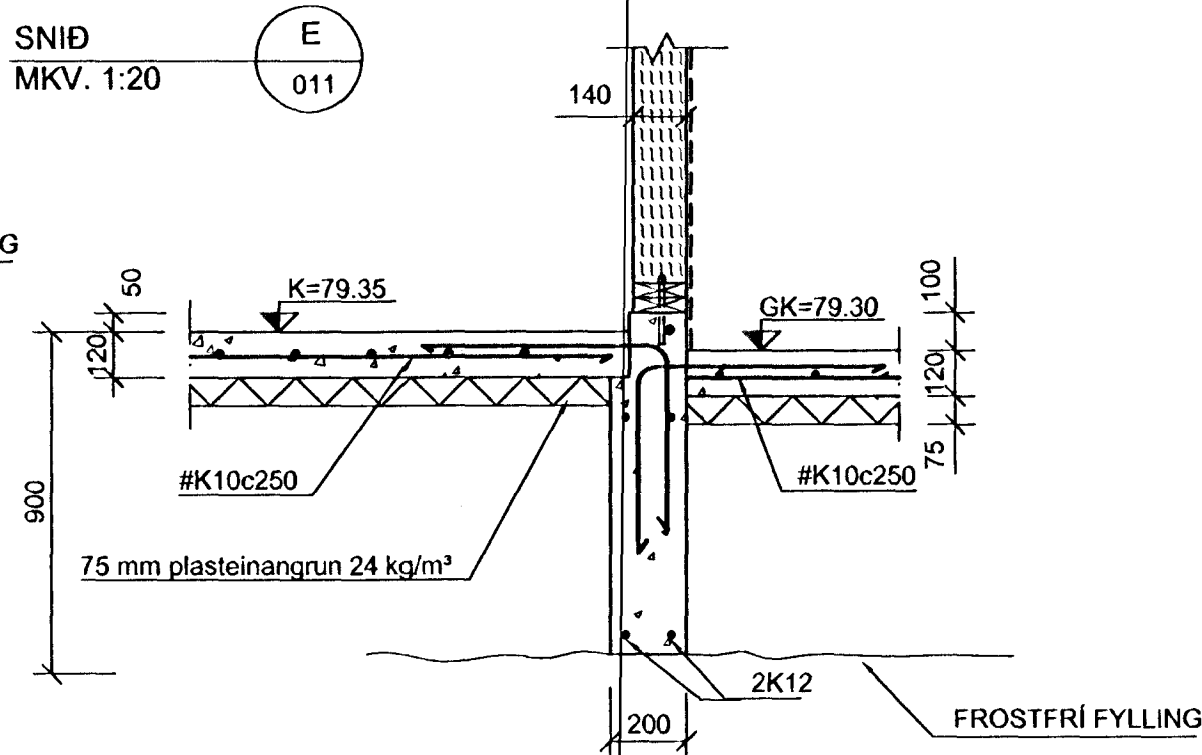

SNID F
MKV. 1:20 011

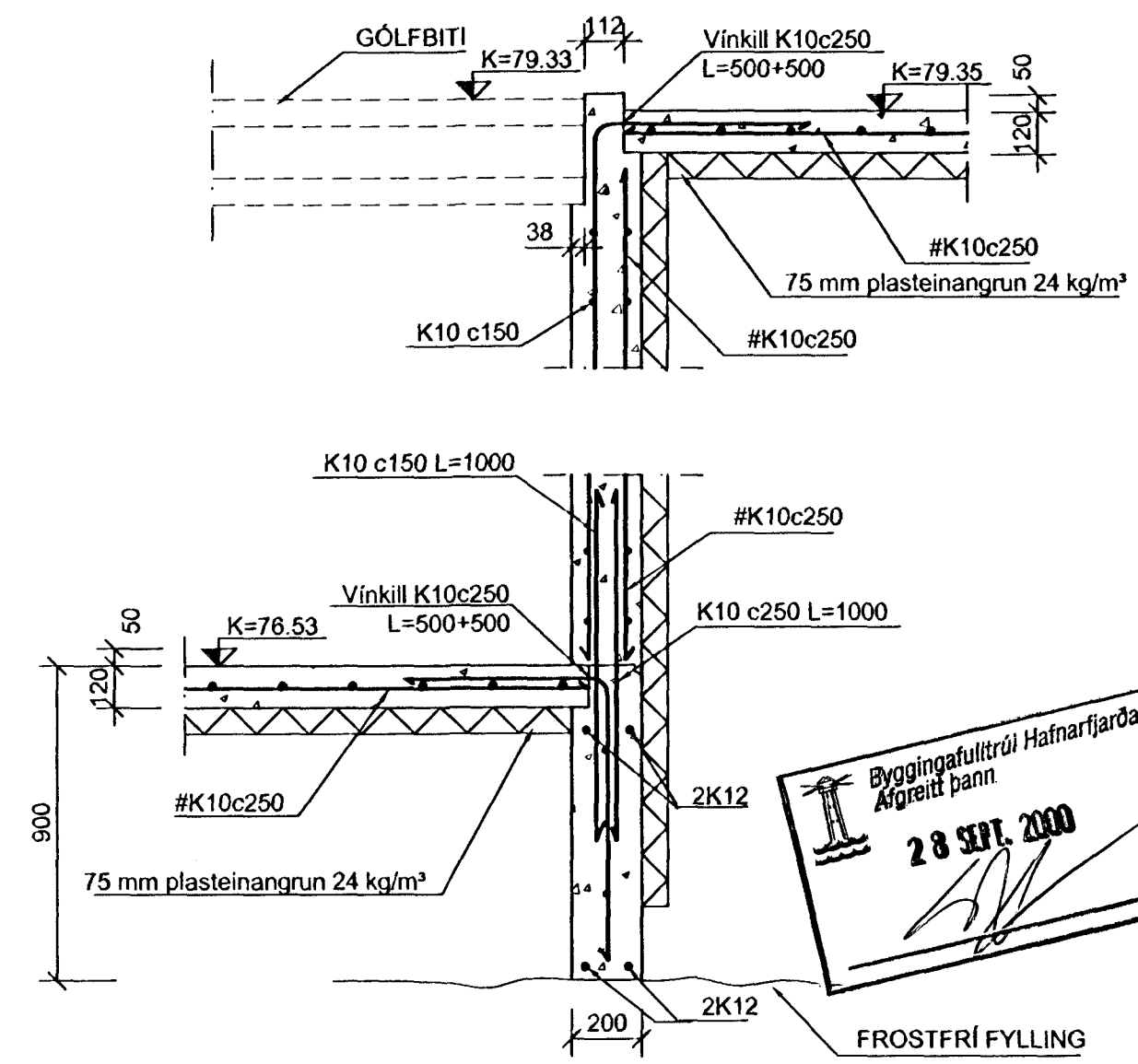

SNID G
MKV. 1:20 011

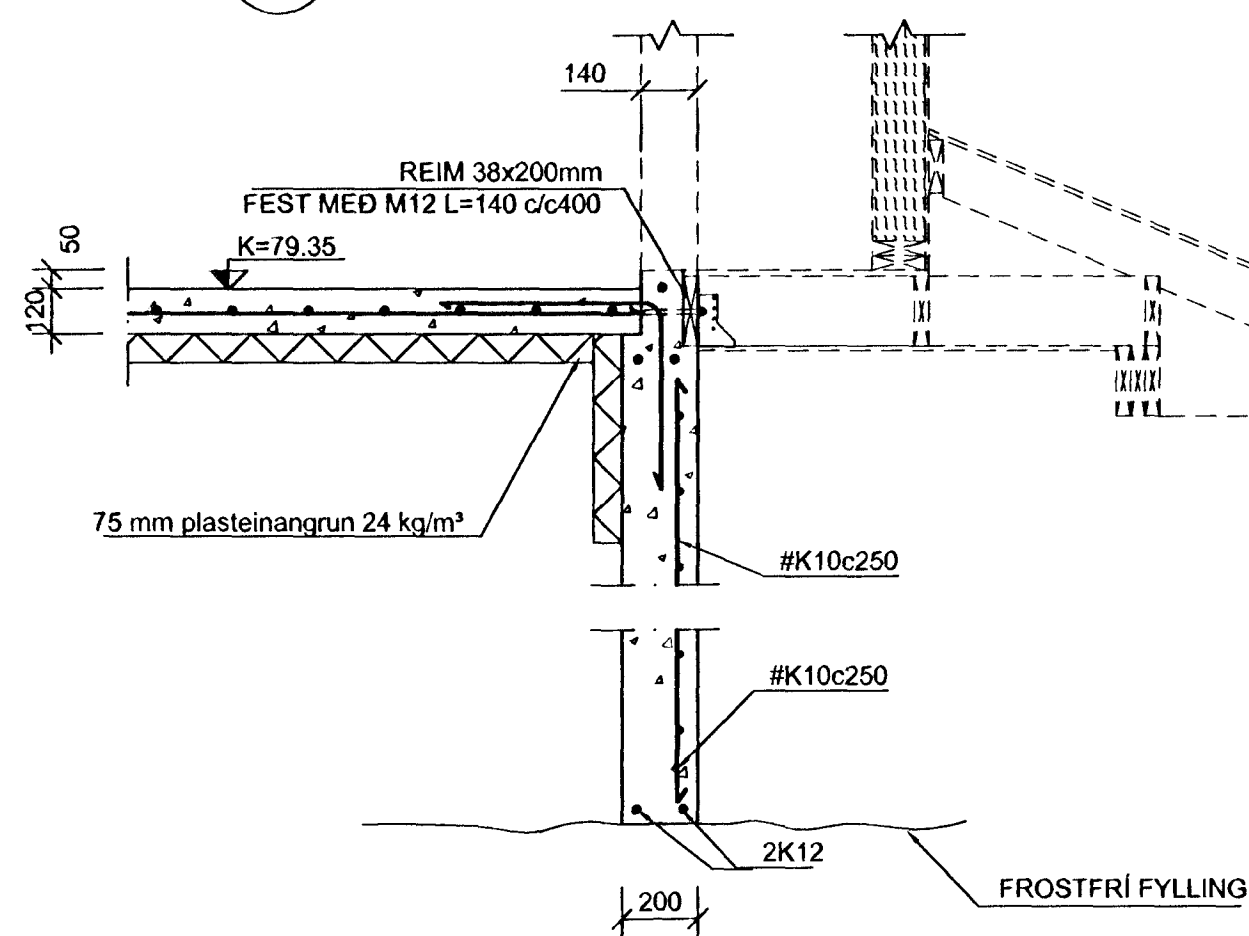

SKÝRINGAR:

ÖLL MÁL ERU í mm
GÖT OG RAUFAR VEGNA LAGNA SJÁ VIÐKOMANDI LAGNATEIKNINGAR
SJÁ ALMENNAR SKÝRINGAR Á TEIKN. NR. 344-010
ÖLL STEYPA SKAL VERA S-250
KÓTAR ERU Í METRUM
ALLAR UNDIRSTÖÐUR HVÍLA Á FYLINGU
GK= ENDANLEG GÓLFHÆÐ
K= HÆÐAR KÓTI
MILLI TIMBUR OG STEYPU KOMI ASFALT PAPPÍ

BENDISTÁL

STAÐSETNING OG BENDING STÁLS SKAL VERA Í SAMRÆMI VIÐ IST-10
K TÁKNAR SUBUHÆFT KAMBSTÁL KS-40S LÁGMARKSSKRÍÐMÖRK 400 N/mm²

Byggingafræðingur
28. SEP. 2000

GAUKSÁS 25 HAFNARFIRÐI		VERKFRÆÐISTOFA SÚÐURNESJÁ EHF. HAFNARGÖTU 5B 230 KEFLAVÍK SÍMAR: 421 5035 & 421 4766 FAX: 421 1660; netfang: vs@vss.is	
HANNAÐ BG	TEIKNAD IB	YFIRE BG	DAGS 22-09-2000
KVARDI 1:20		NR. 344-012	
SAMP Kumpfle Guðm. Jón		VS006501	