

Grunmynd stíghús 1-4 hæð 1:20

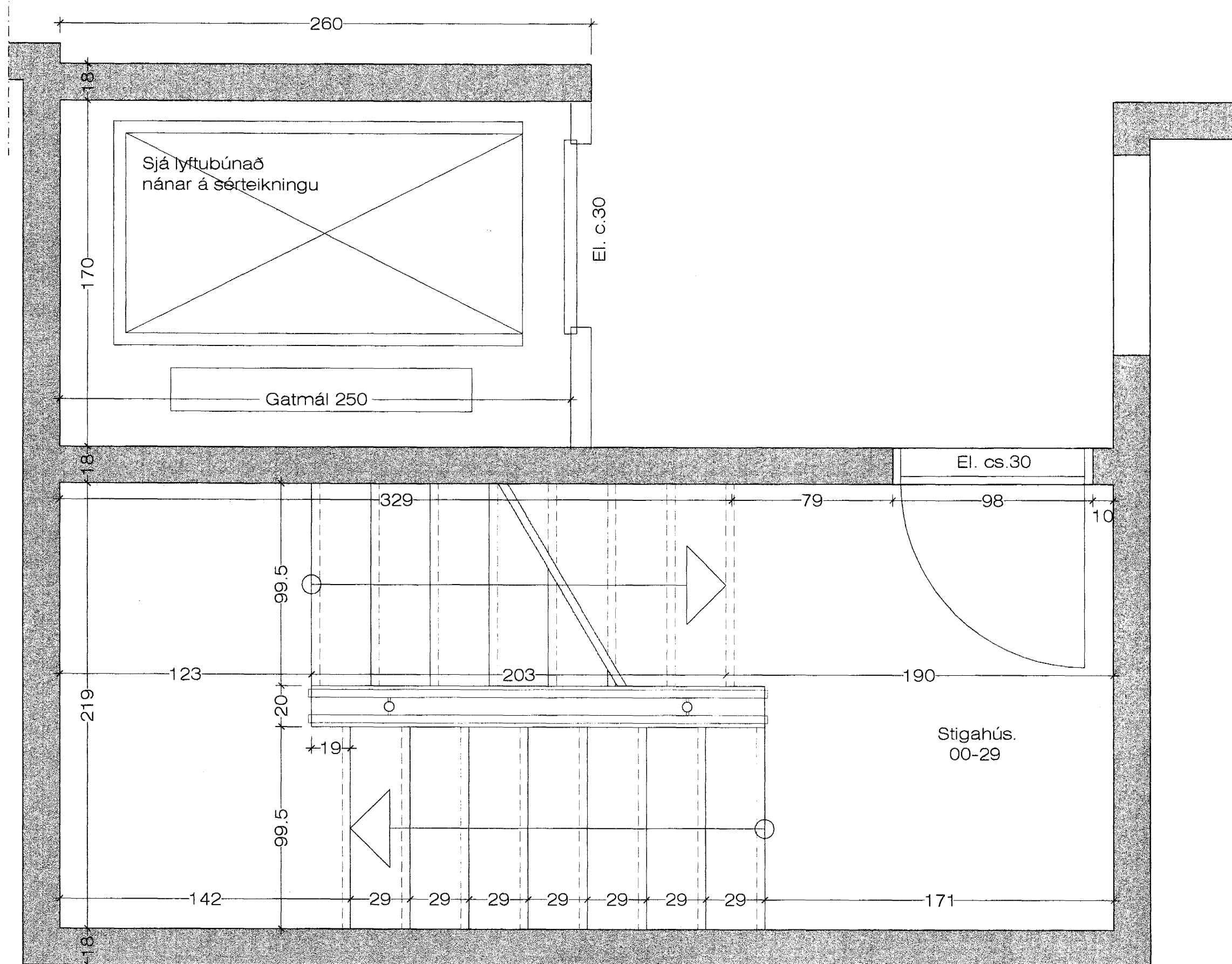

Grunmynd stíghús kjallara 1:20

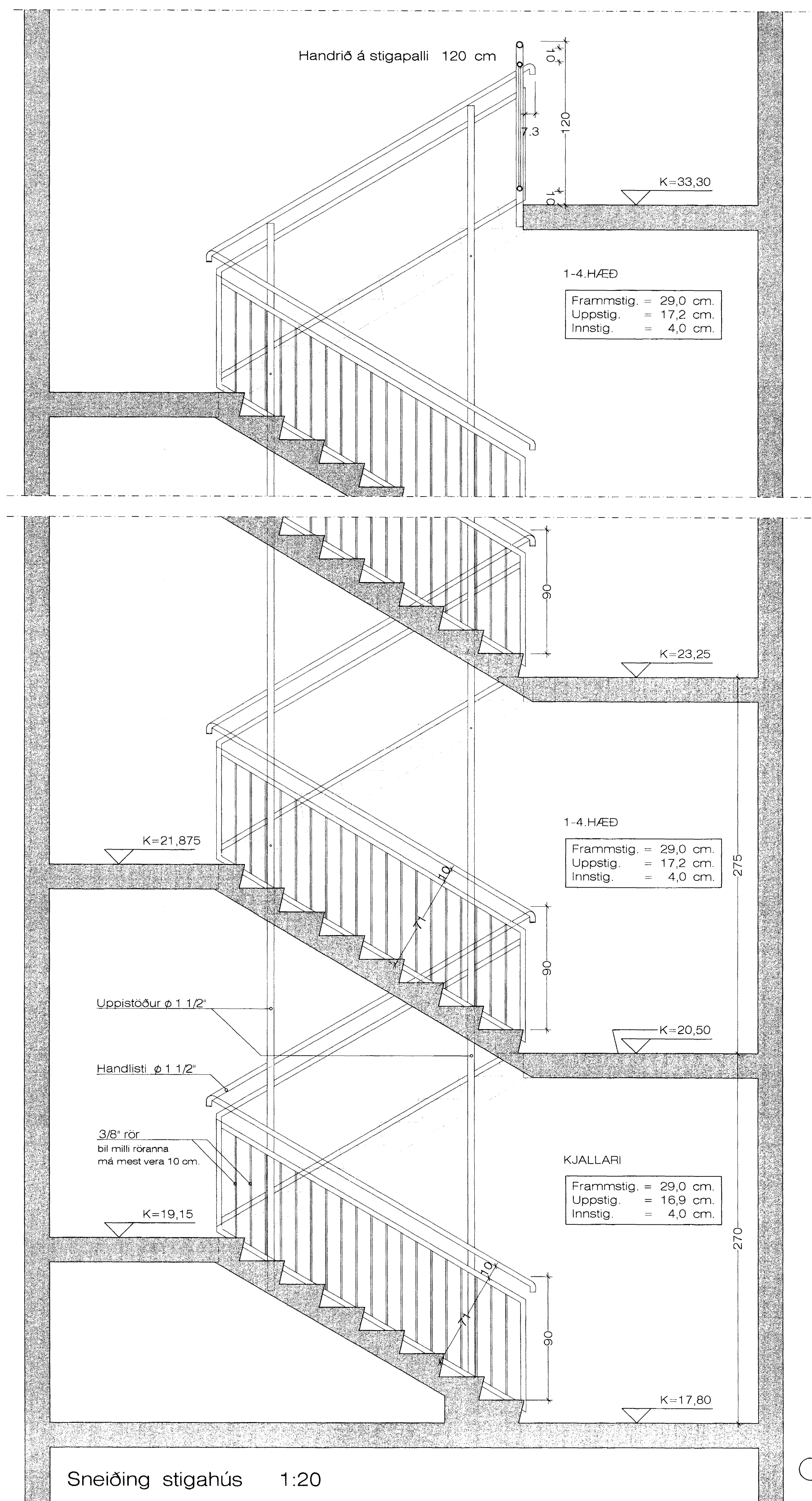

Sneiðing stíghús 1:20

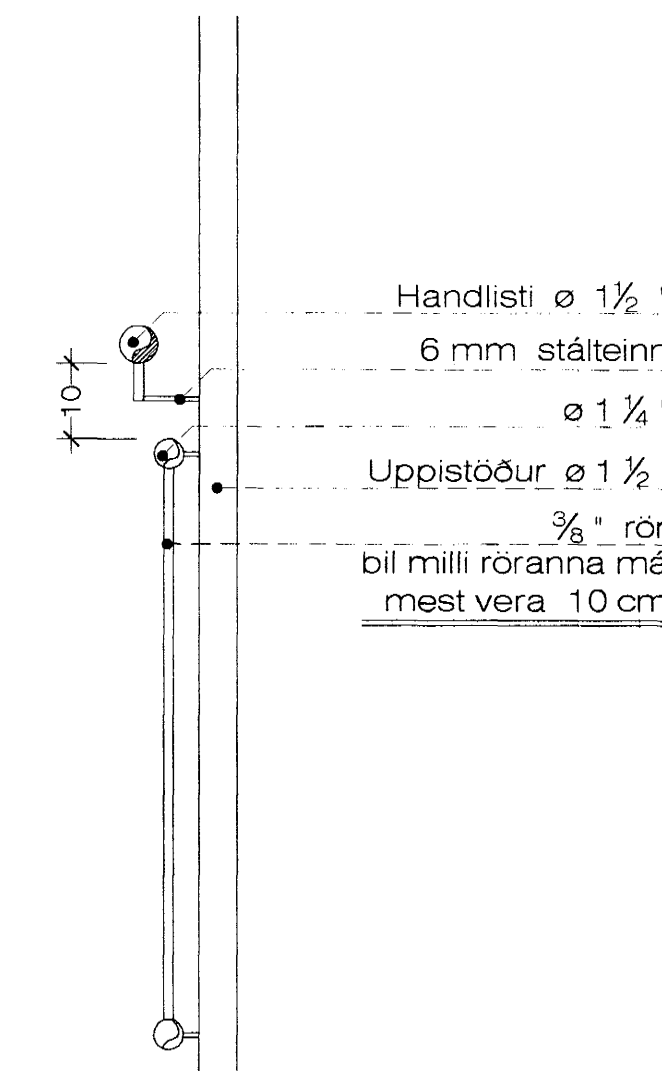

Handrið hlutamynd 1:10

Athuga skal öll mál nákvæmlega á staðnum áður en smíði hefst.

Samþykkt þann  
29 NOV. 2004  
Byggingafulltrúinn í Hafna  
F.h. Sigurbjartur Halldórs.

Jón Guðmundsson, arkitekt. Suðurlandsbraut 16 2.11.2004 08:31 Eskv. 2002.dwg