

Höfundur eldri bygginga: Þorvaldur Kristmundsson

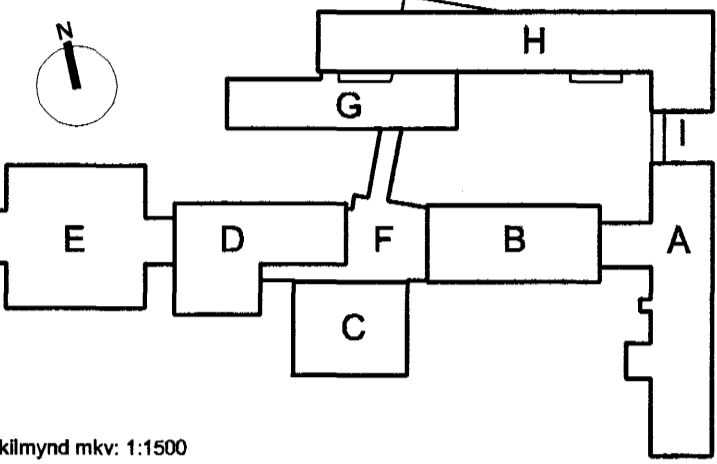

Lýðmynd m.k.v: 1:1500

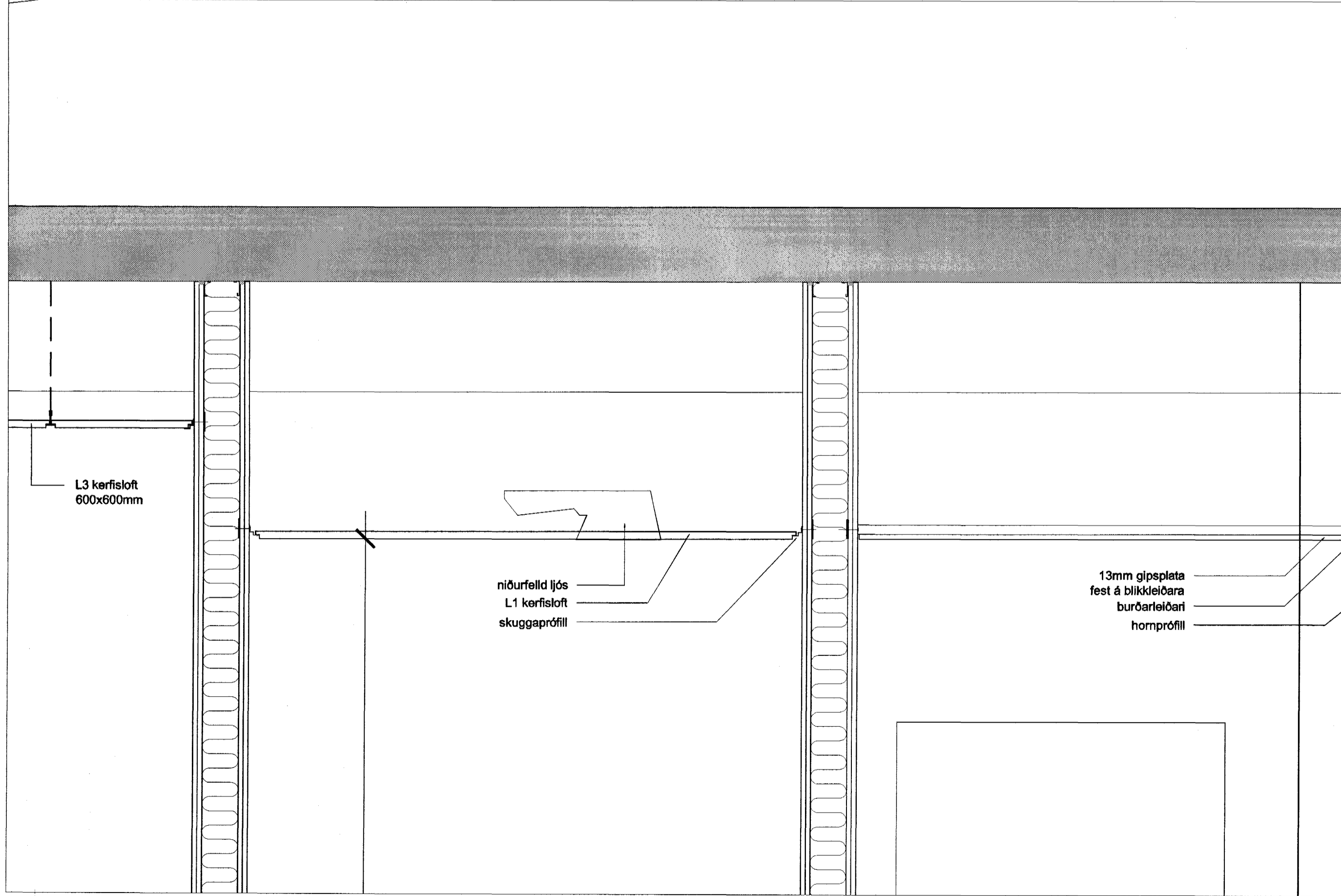
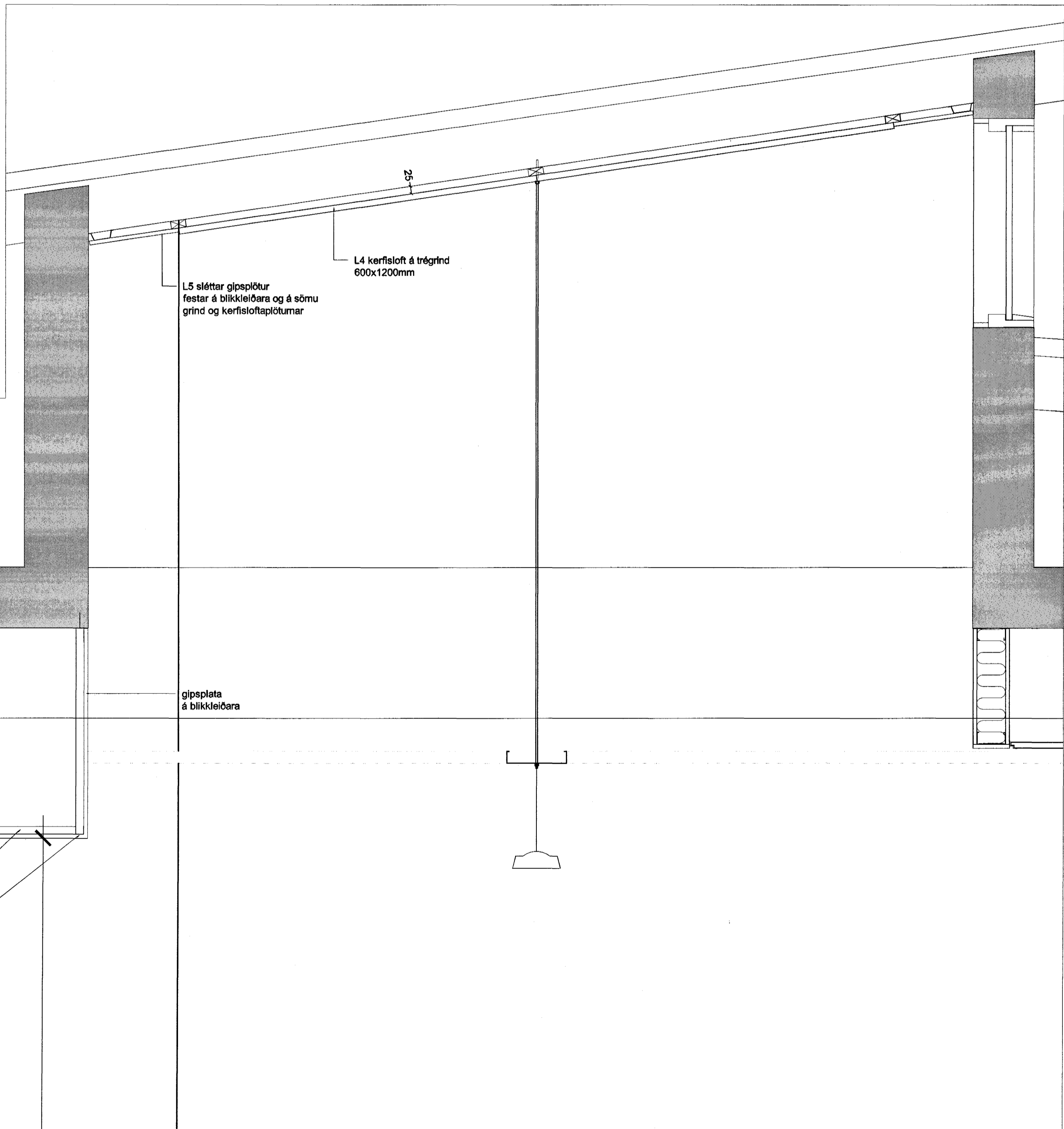
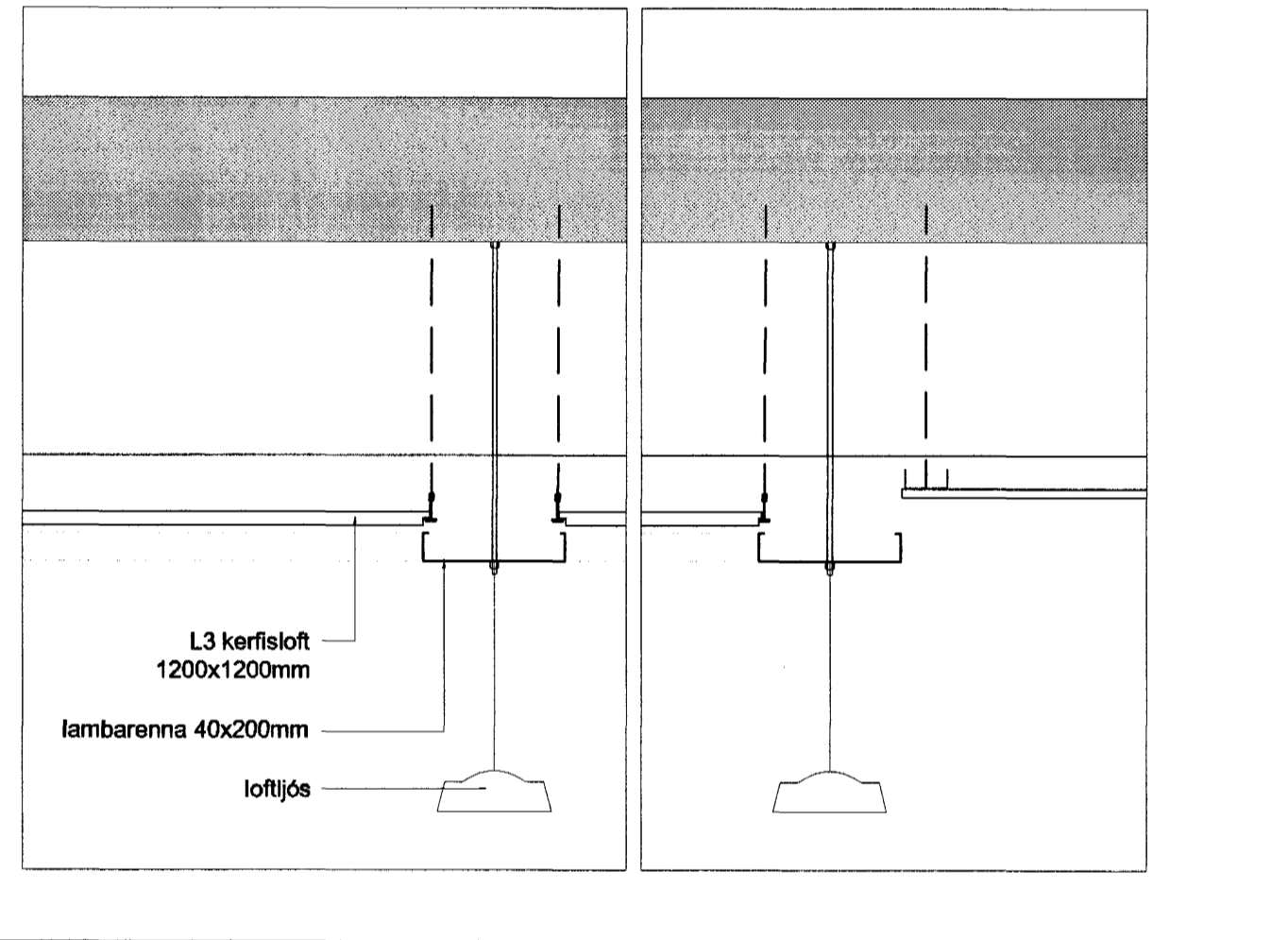
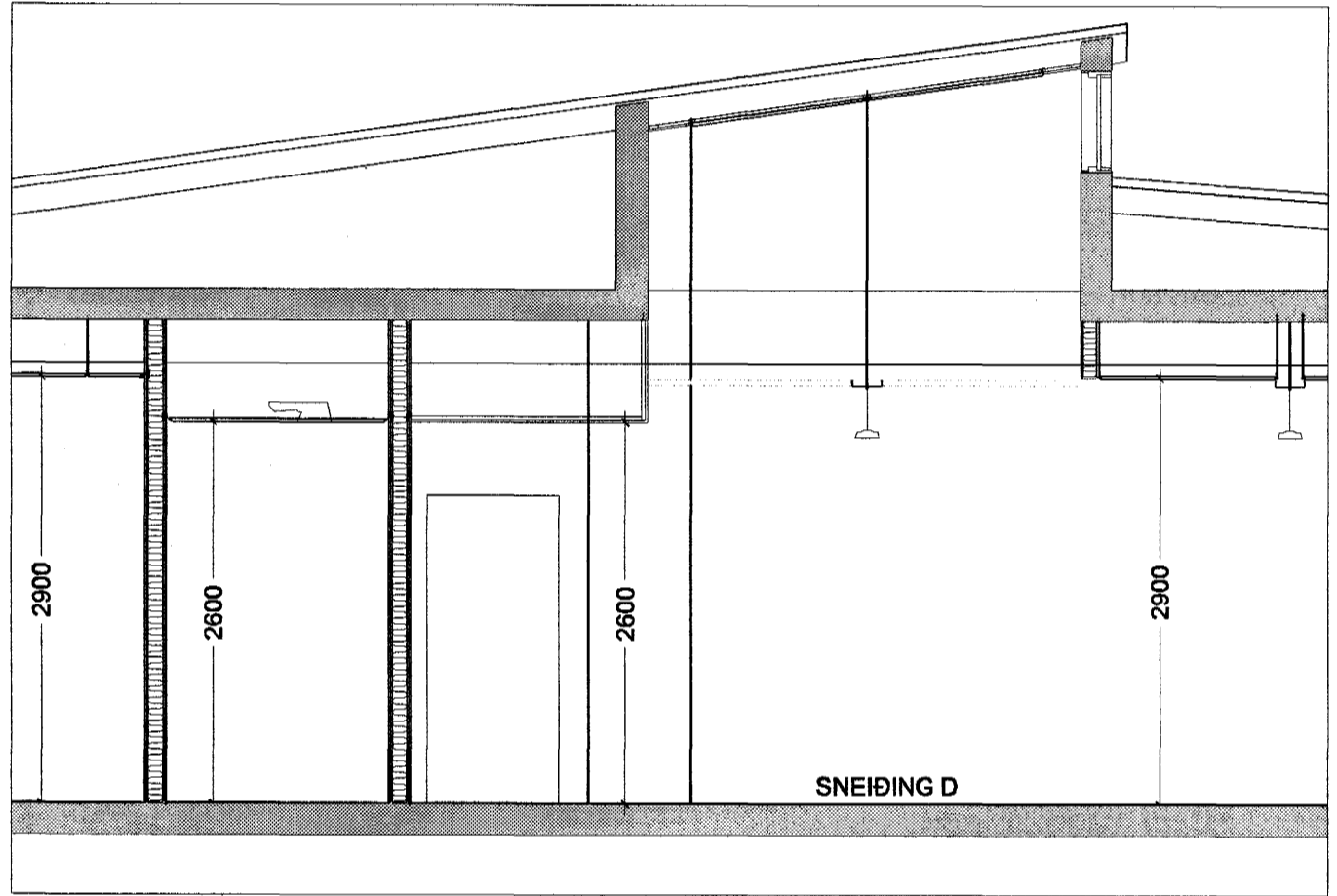

Byggingaútrúð Hafnarfjarðar
Afgreitt þann
21 AUG. 2003
VG
VINNUTEIKNING
04 JUN 2003

Fastelgnafélag Hafnarfjarðar
VIÐIÐAÐASKÖLI, VIÐBYGGING
Hrauntungu 7, stgr. 1400-01 43100070 0240
VERKTEIKNING
GRUNNMYND, KERFISLAUSNIR Á LOFTUM
1. HÆÐ
MKV.: 1:10 / 1:50
DAGS: 14.03.2003
TEIKNAD: AE
SKRÁ: 0240, (45)4.01-(45)4.03.dwg (49)4.03
Frumútg.

BATTERÍÐ
ARKITEKTAR
Jón Ólafur Ólafsson FAI
kt: 090658-3999
Stjórnur Eyrjasson FAI
kt: 110457-3989
S: 54 54 700 F: 54 54 701
Netfang: batteri@arkitekt.is
Heimasíða: www.arkitekt.is