

GRUNNMYND 1:50

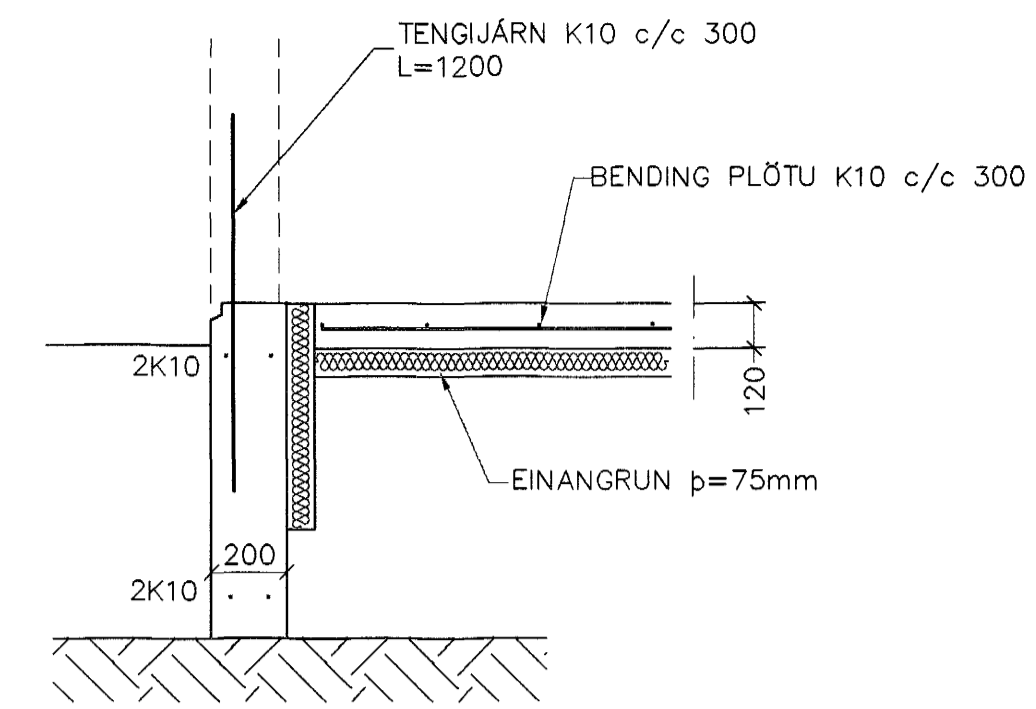

SNID 1 1:20

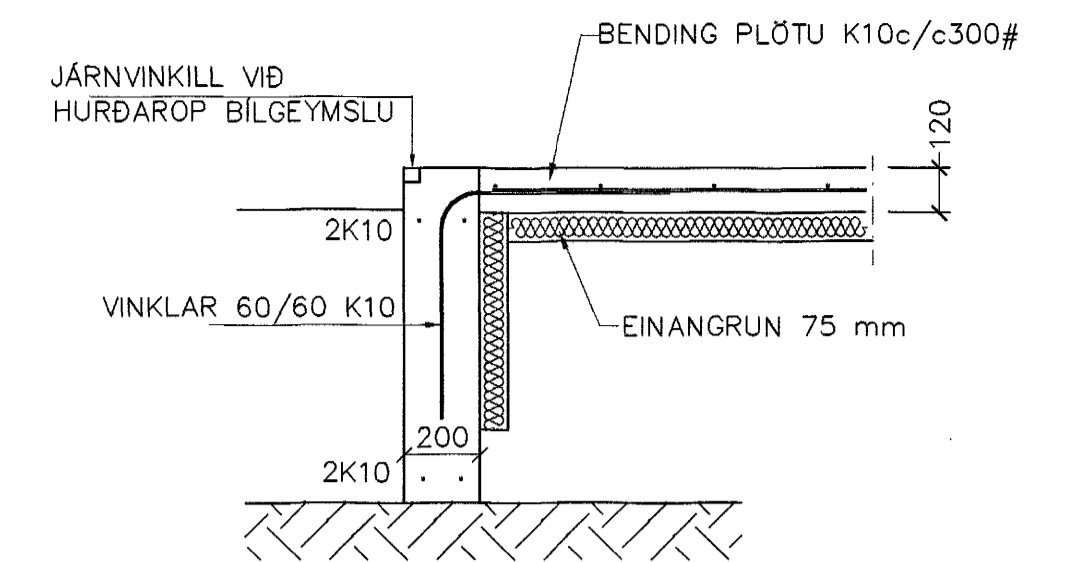

SNID 2 1:20

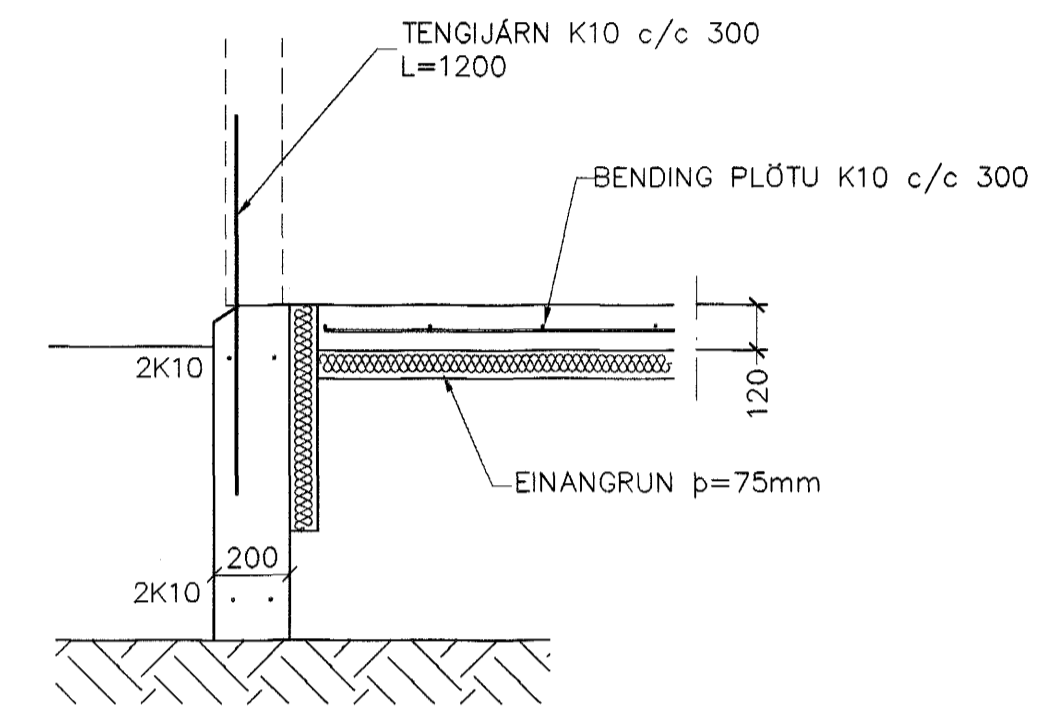

SNID 3 1:20

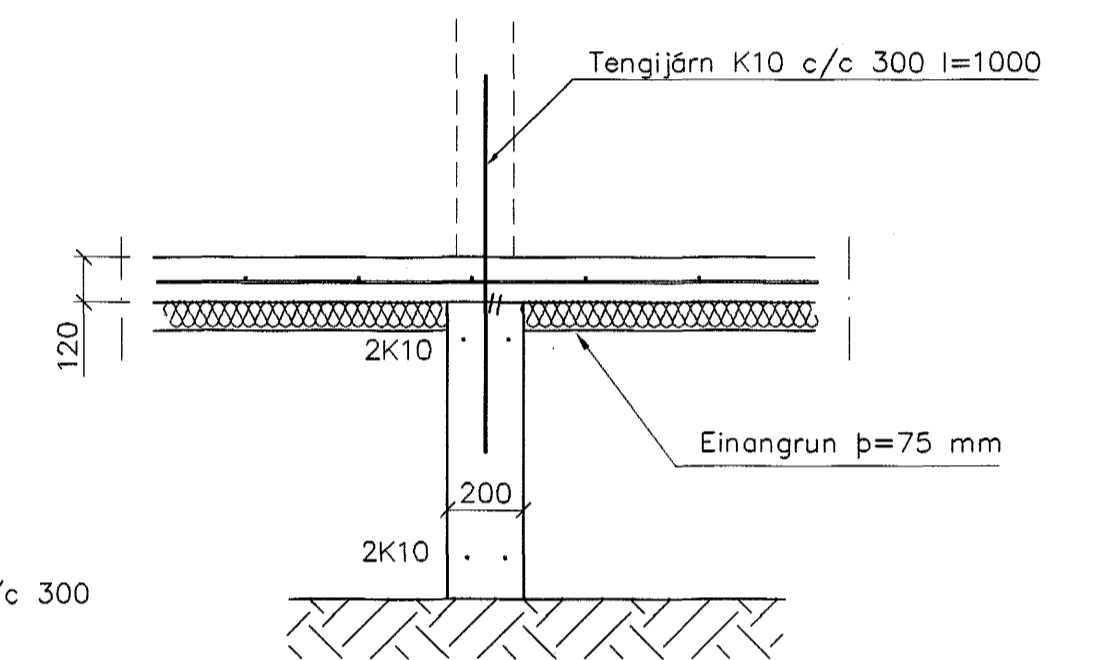

SNID 4 1:20

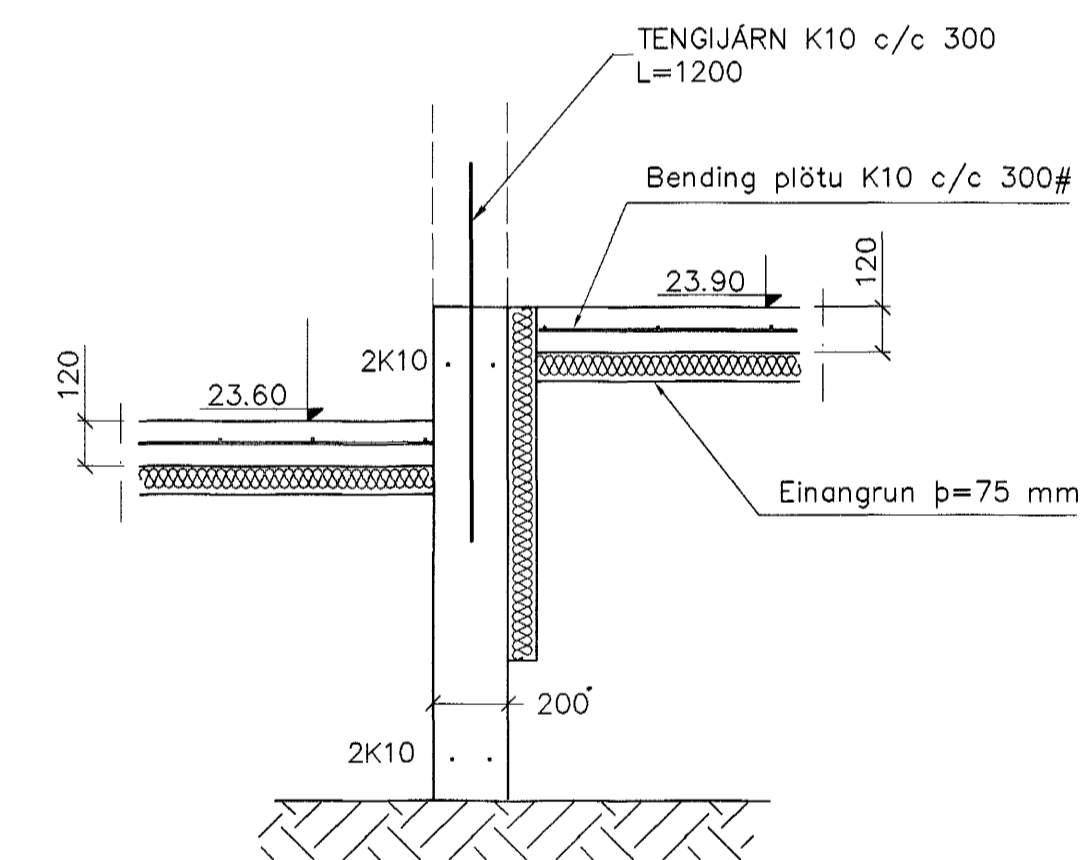

SNID 5 1:20

SKÝRINGAR

STEYPA=S250
 LOFTINNIHALD > 5%
 V/S-TALA < 0,55
 BENDISTÁL= Ke410
 HÆÐ UNDIRSTAÐA ER > 100 SM
 FÝLLING INN Í SÖKKLA SKAL VERA FROSTFRÍ
 OG ÞJAPPAST Í 30 SM LÖGUM
 UNDIRSTÖÐUR HVÍLA ÞJAPPADRI FÝLLINGU
 ÞJÖPPUNARKRÖFUR E2 > 120 MPa, E2/E1 < 2,3.
 MESTA ÁLAG Á UNDIRSTÖÐUR < 500 kN/M

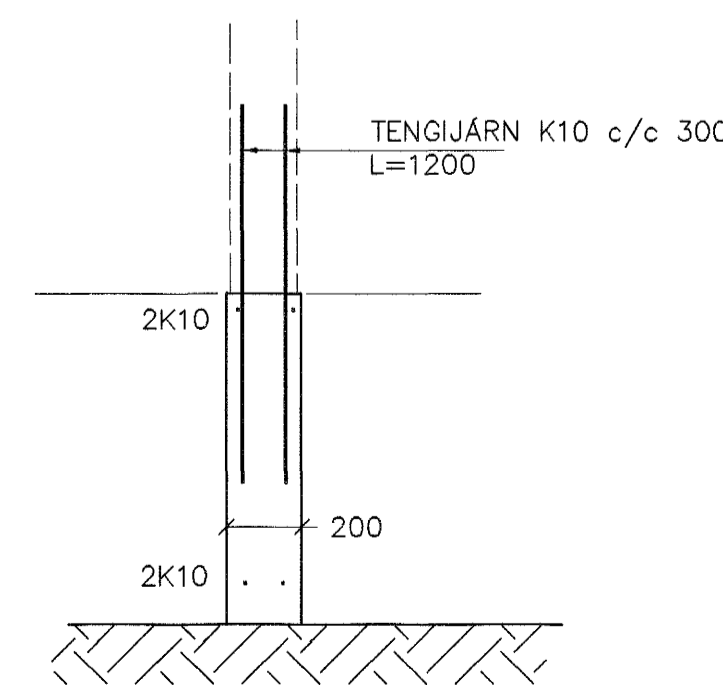

SNID 7 1:20

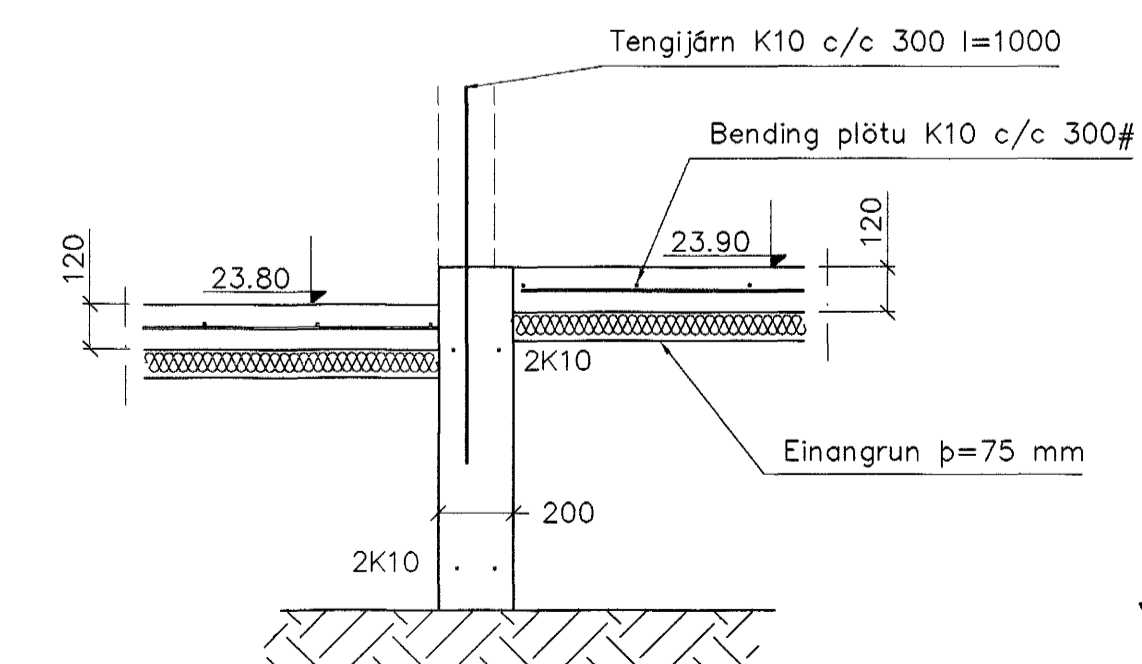

SNID 6 1:20

Br.	Dags.	Eðli breytinga	Sign
BURKNAVELLIR 9 HAFNARFIRÐI			
UNDIRSTÖÐUR-MÁLTEIKN			
MKV. 1:50 1:20			
DAGS. MÁL. 2003			
VERK NR. 2307			
TEIKN. NR. 1-01			
HANNAD SIG. ÞORLEIFSS. KT. 241148-3009			
TEIKNAD G.H.			
HAFNARFIRÐI			
TAEKNIÞJÓNUSTA SIGURÐAR ÞORLEIFSSONAR ehf STRANDGÖTU 11 220 HAFNARFIRÐI Sími 555-4255 FAX 565-2875 E-mail taeknihjonusta@islandia.is			