

GRUNNMYND 1:100

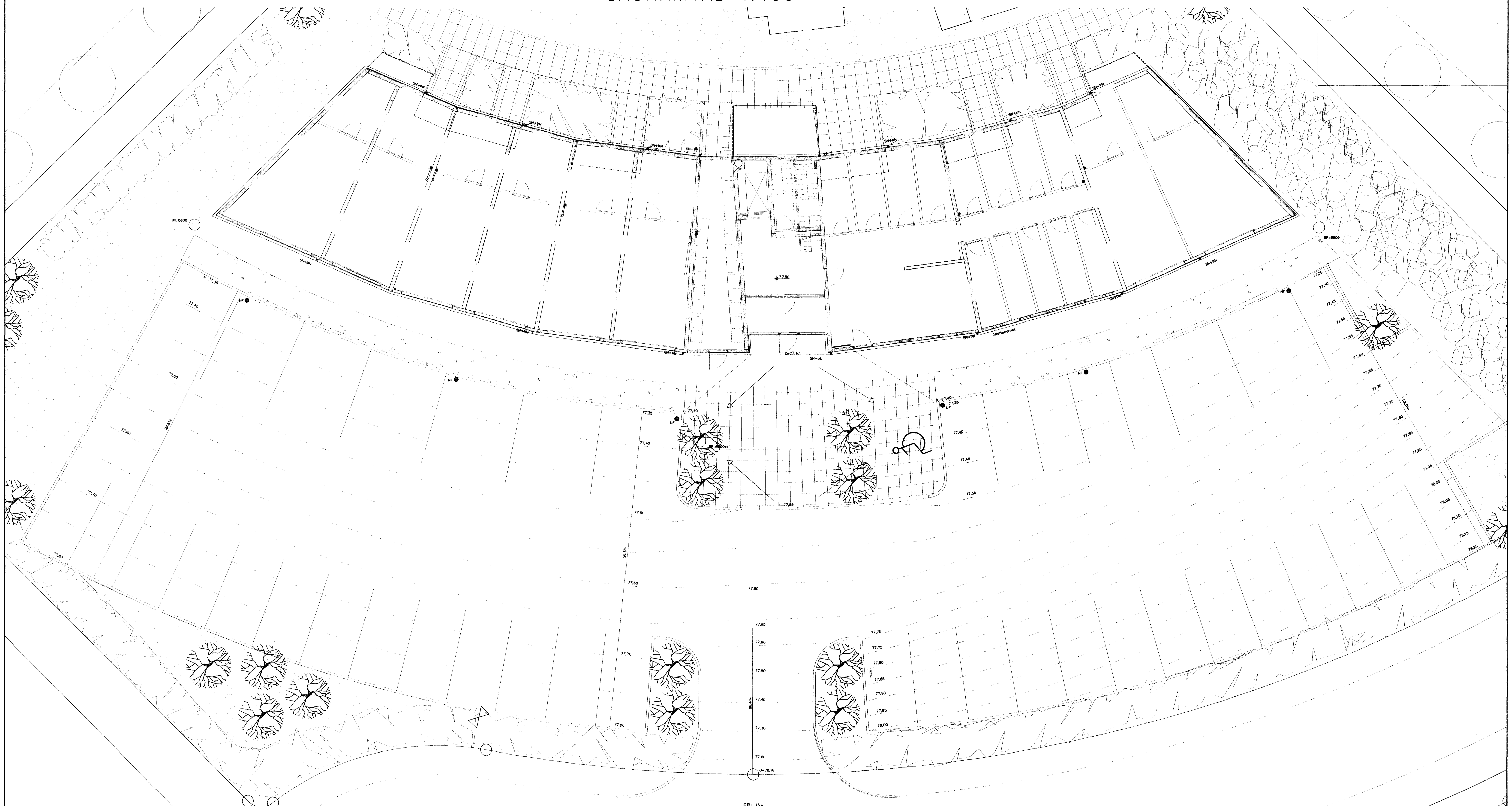

FRÁGANGUR 1:20

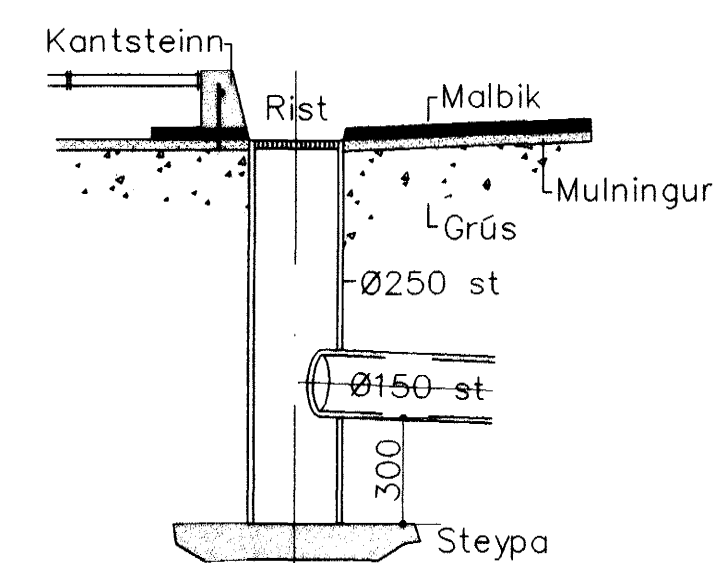

Málsetningar á plani skulu vera samkvæmt *Byggingarreglugerð Alþingis, Part 1*

2* Batt við anjöræðlu framan við inngangsdýr íbúða

25 JUNI 2003

Breytingar		ERLUÁS 2 HF.	H BS T BD S
Nr.	Dags.Nafn		
1	21.11.02 BS	Verkfæðistofa Þráinn & Benedikt Laugavegi 178, 105 Rvk. Sími: 553 1770, 568 7775, Fax: 568-7701 Netfang: post@islandia.is	M 1:100/20
2	14.03.03 BS		Nr. S101
		Hæðarlega bílastæði	Dags. 080149-3608