

20 SNID 1:20

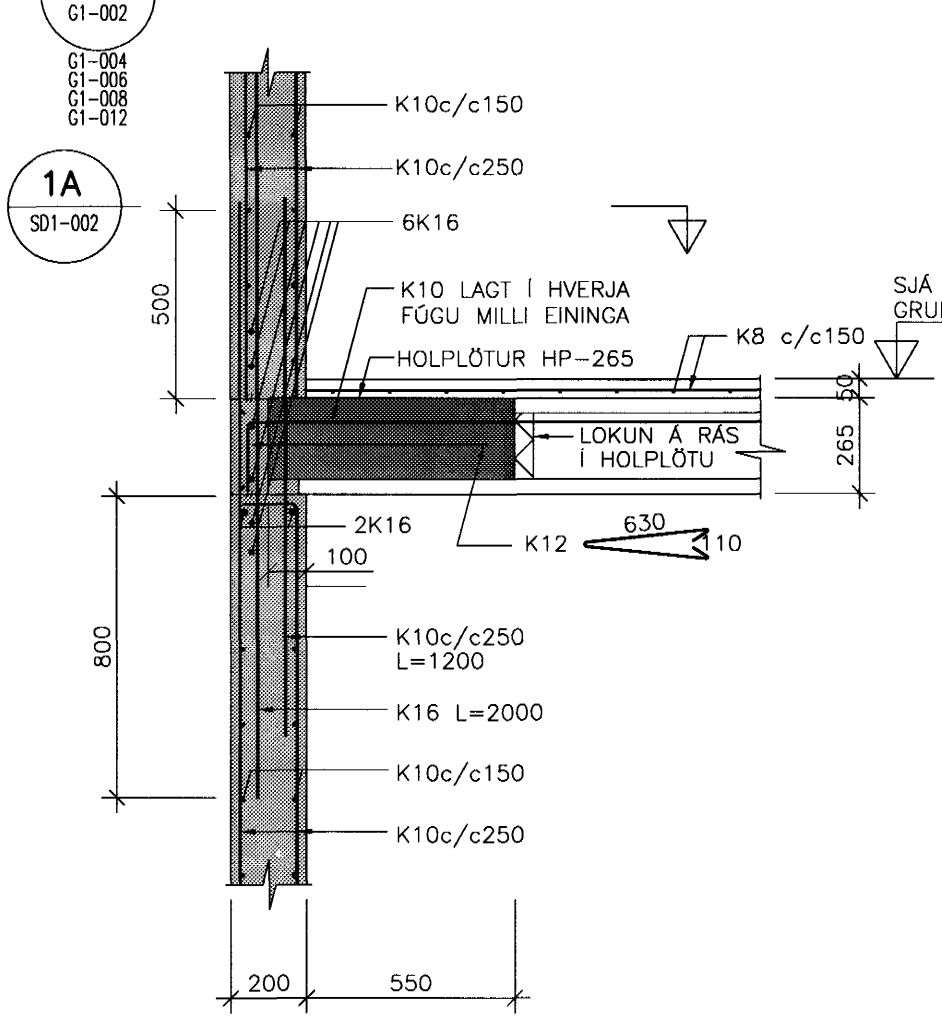

21 SNID 1:20

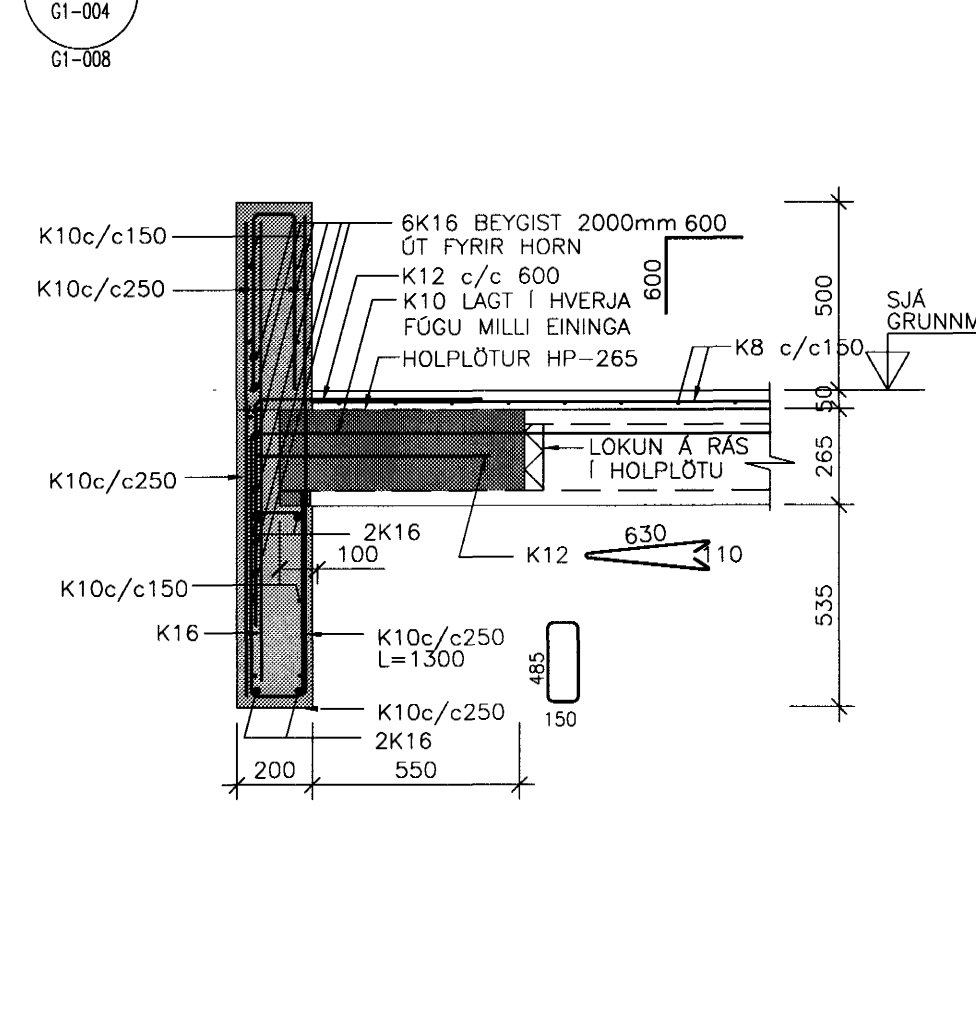

22 SNID 1:20

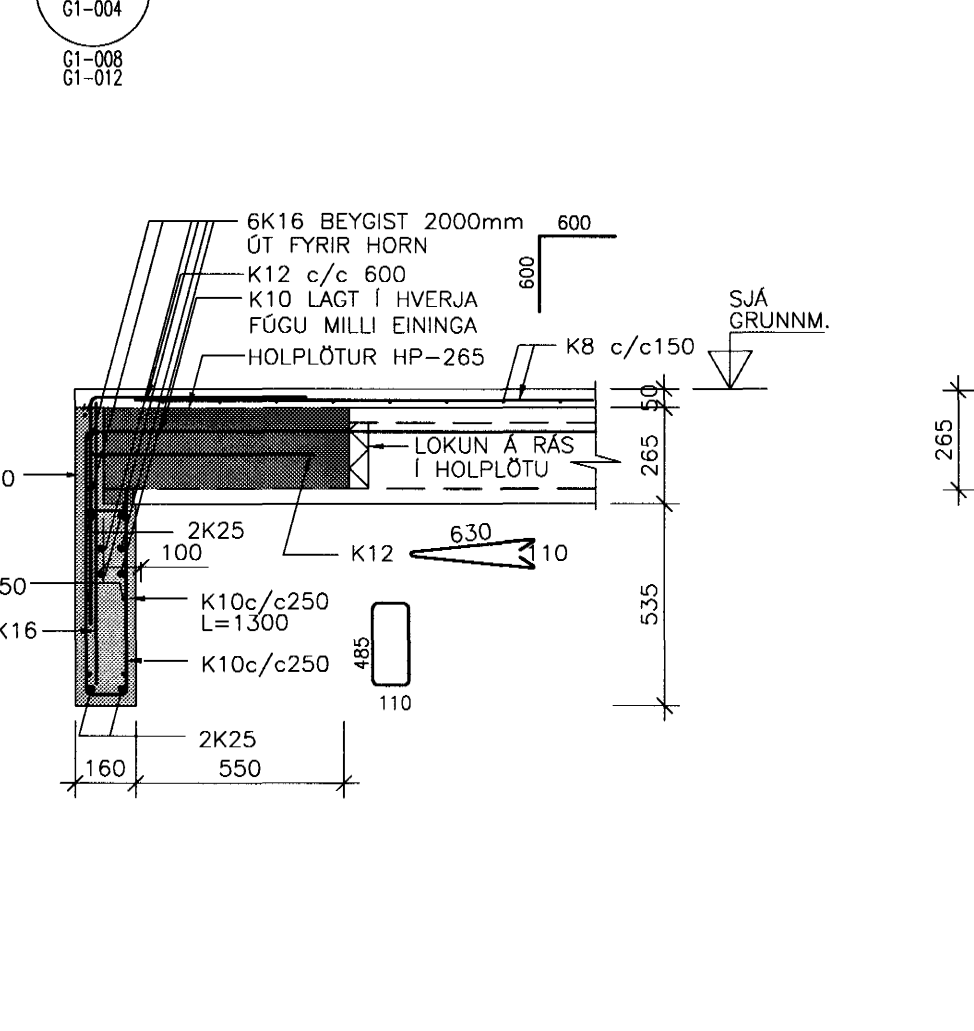

23 SNID 1:20

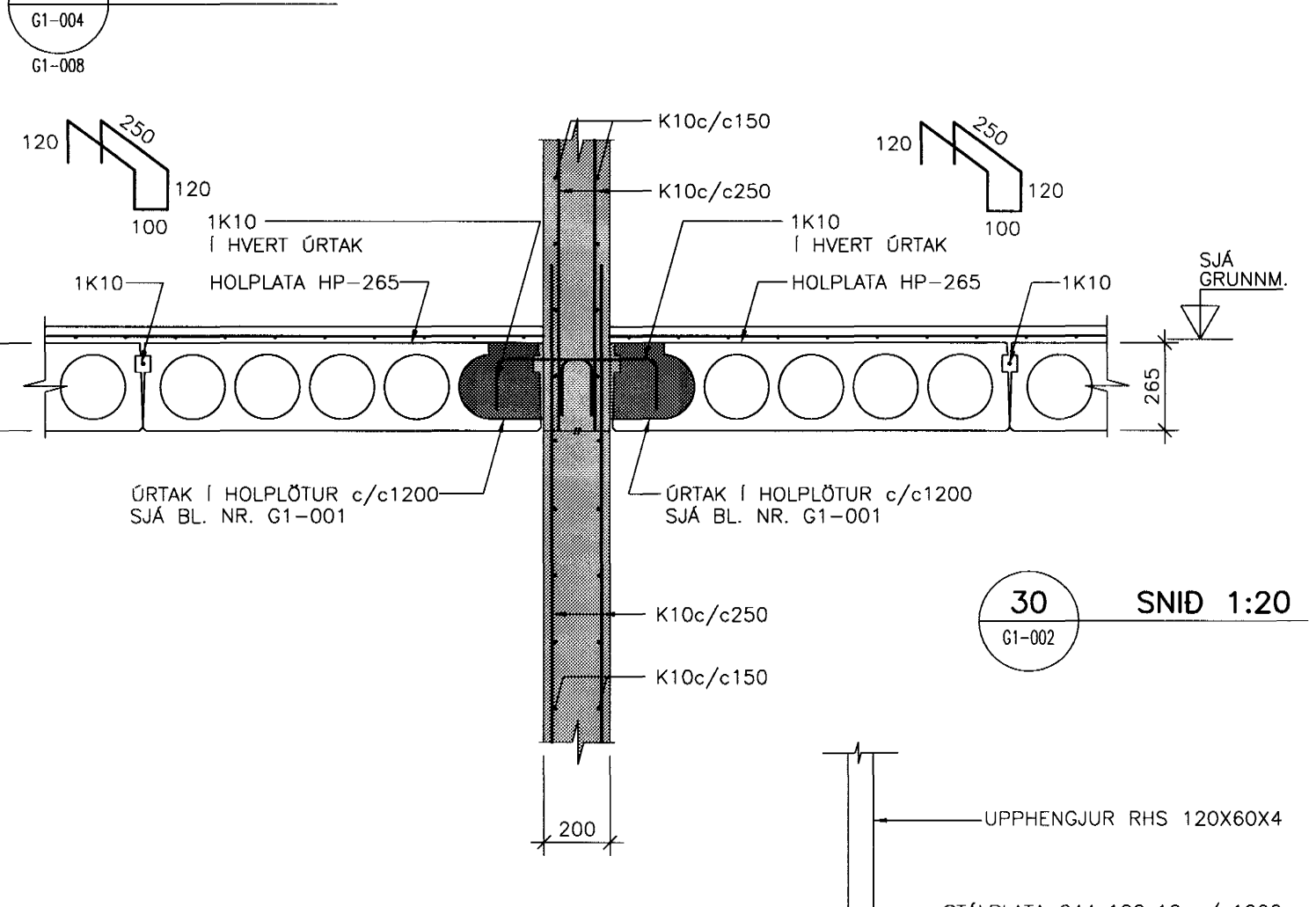

30 SNID 1:20

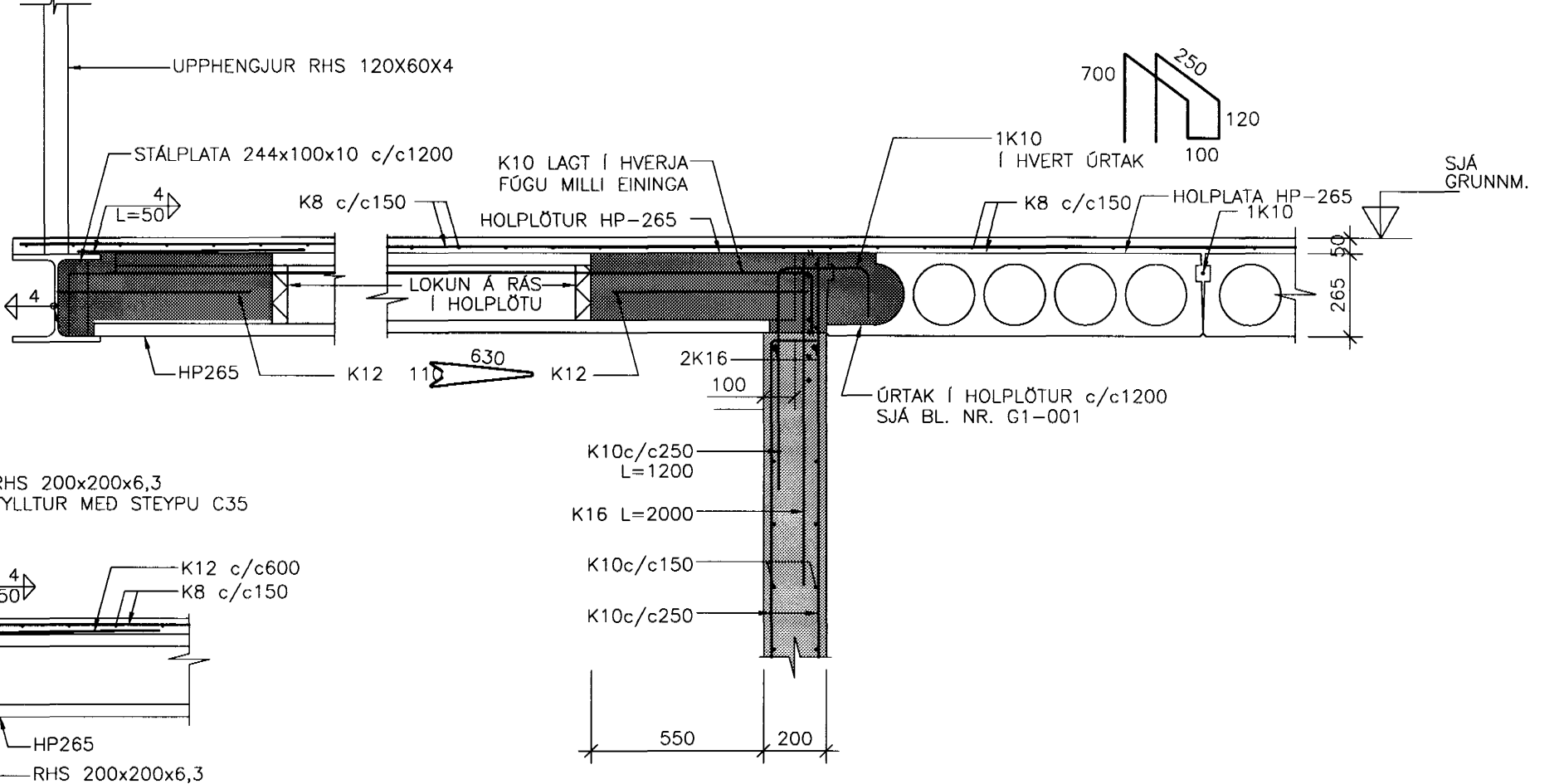

1A SNID 1:20

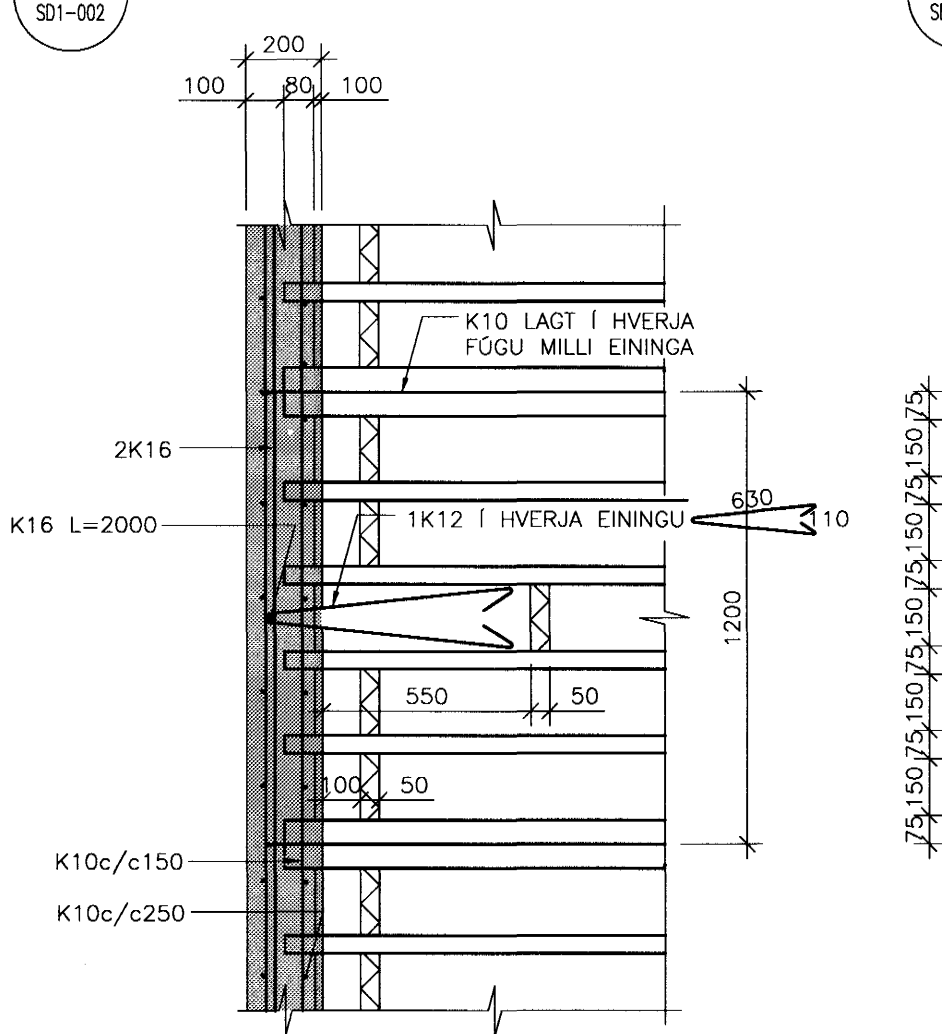

1B SNID 1:20

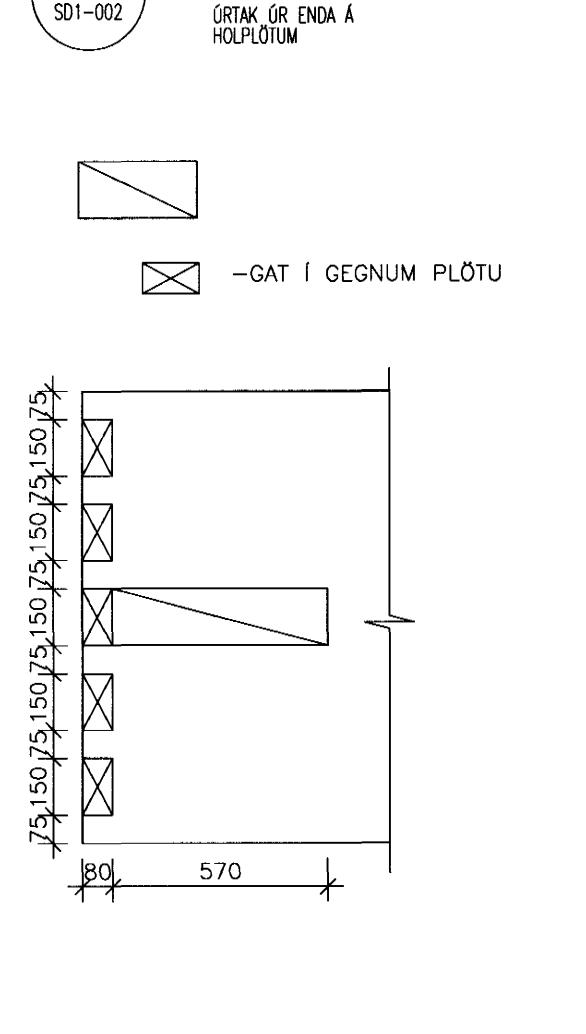

24 SNID 1:20

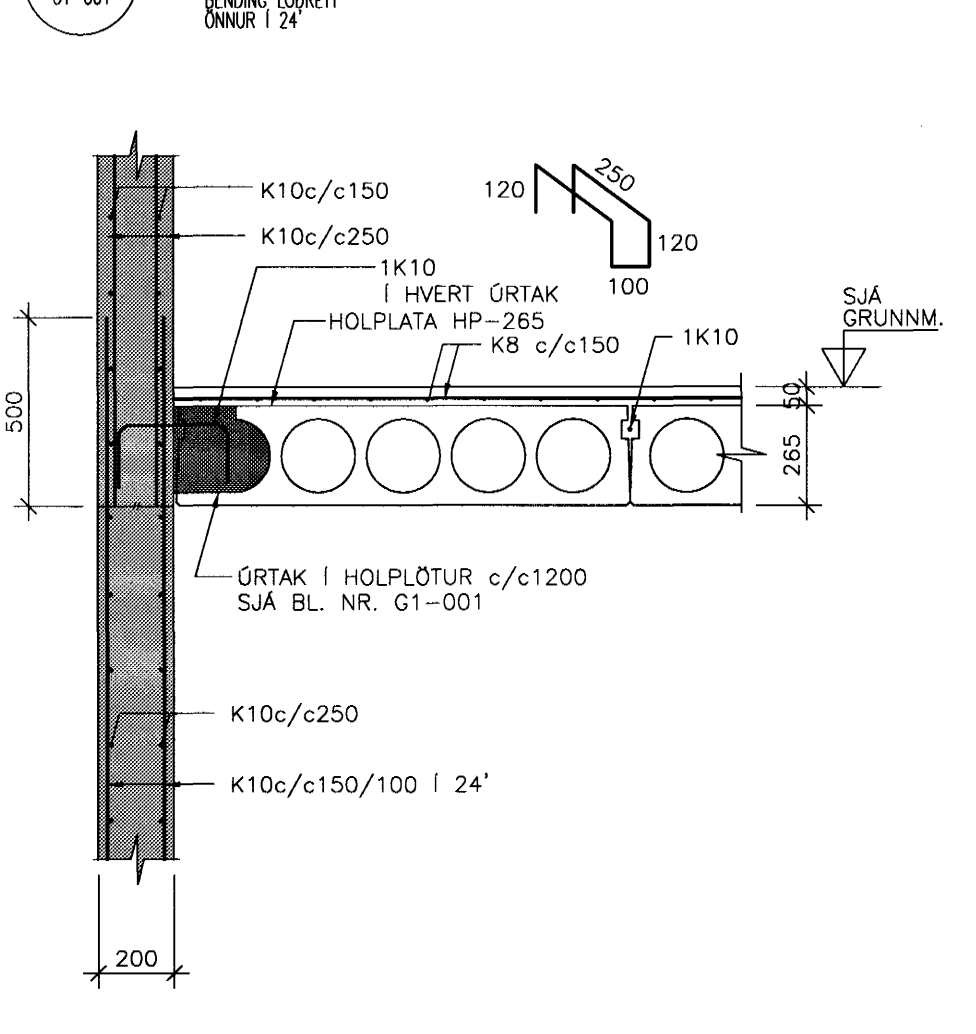

25 SNID 1:20

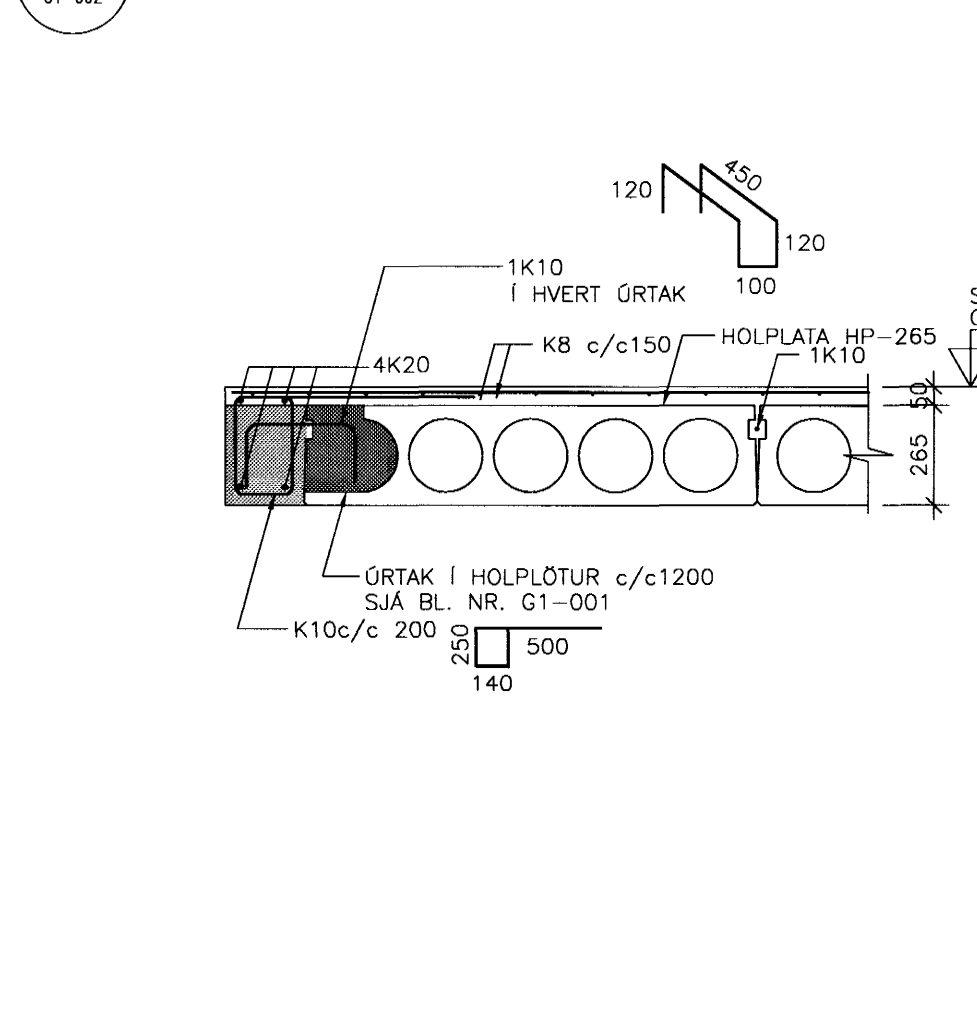

26 SNID 1:20

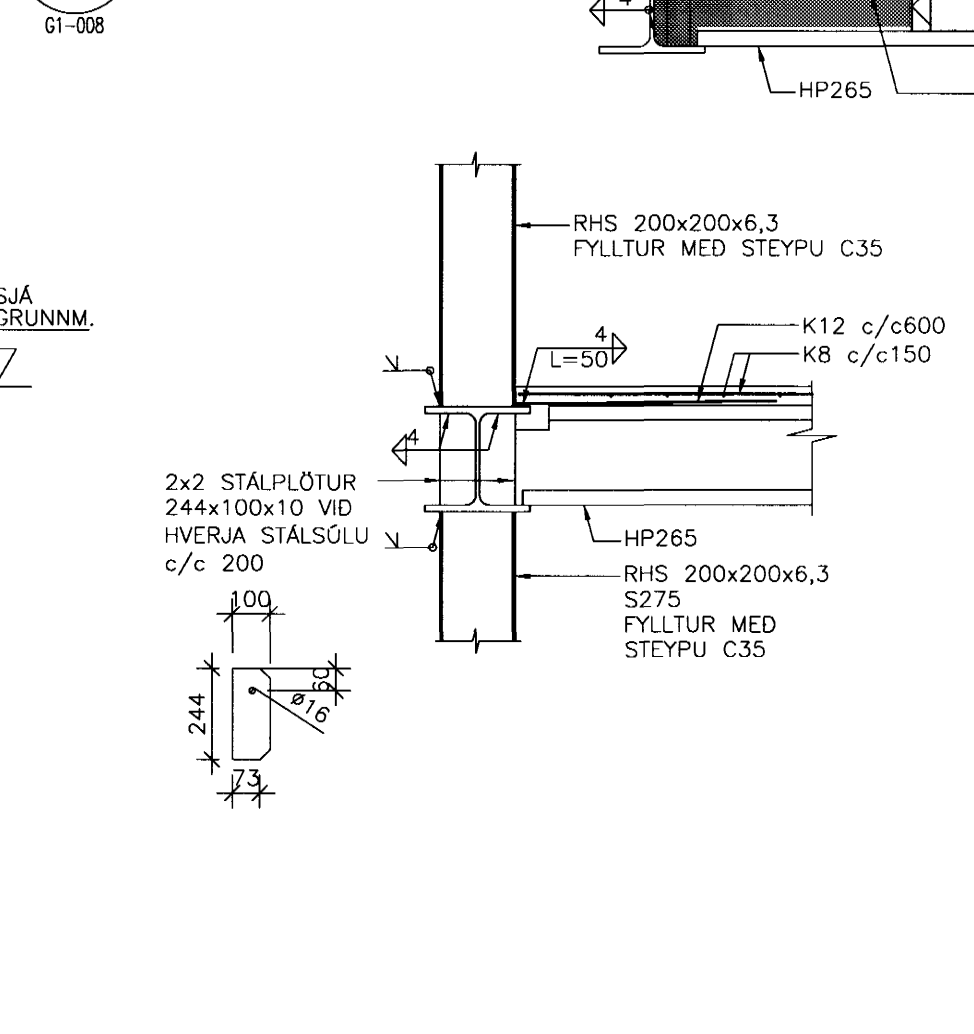

27 SNID 1:20

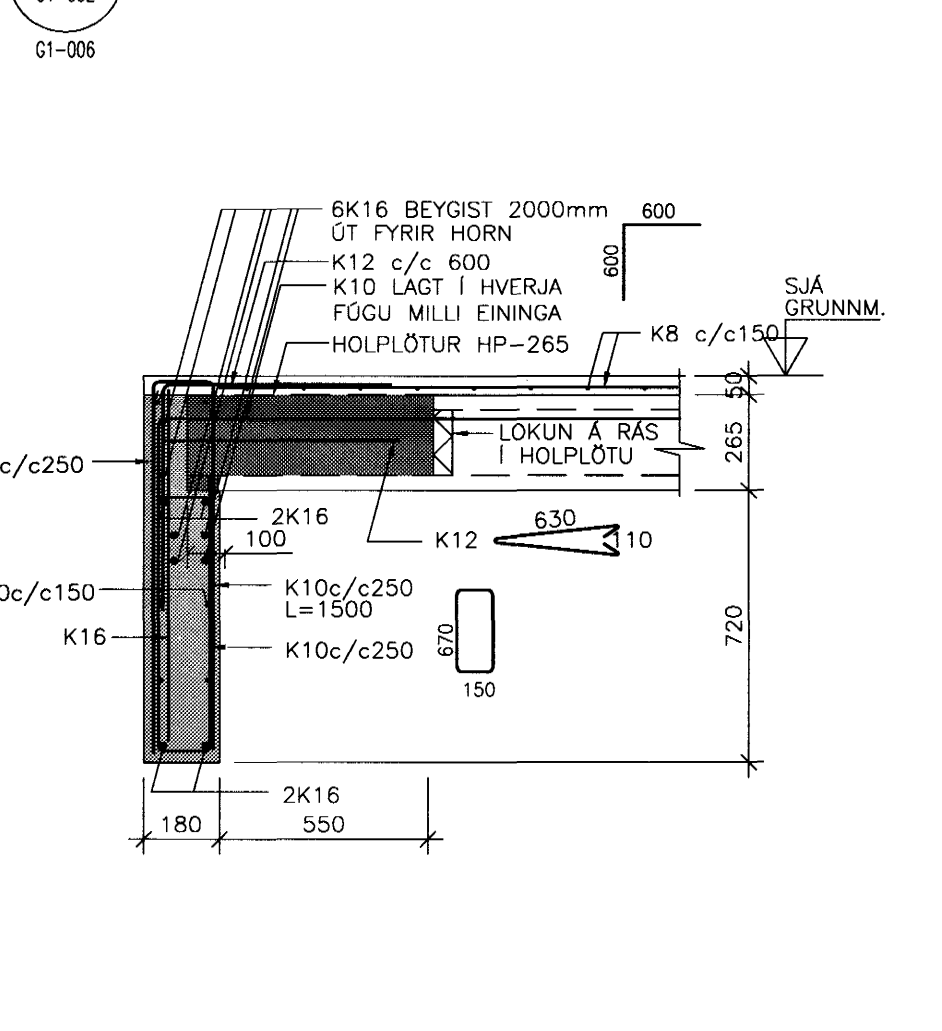

28 SNID 1:20

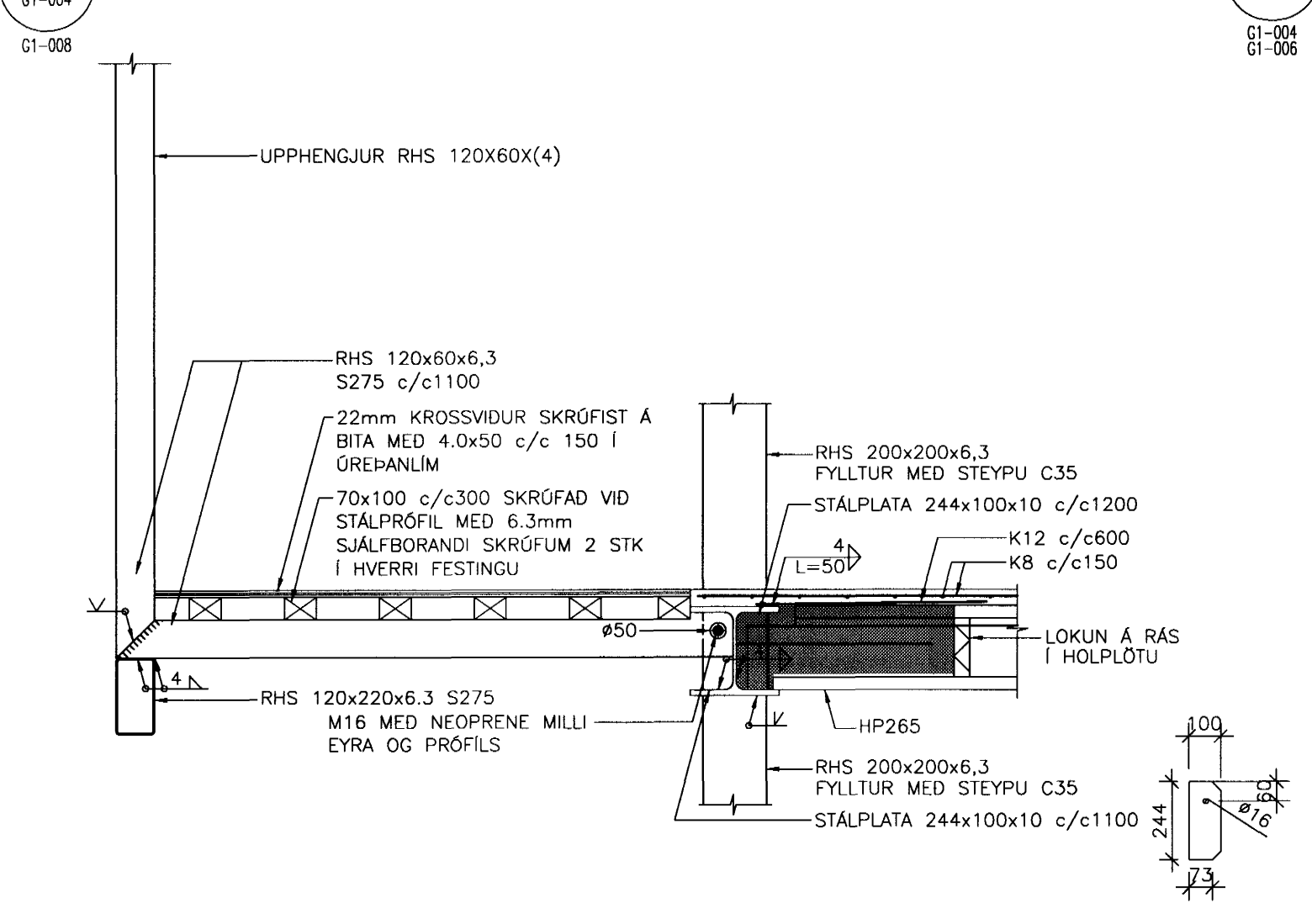

29 SNID 1:20

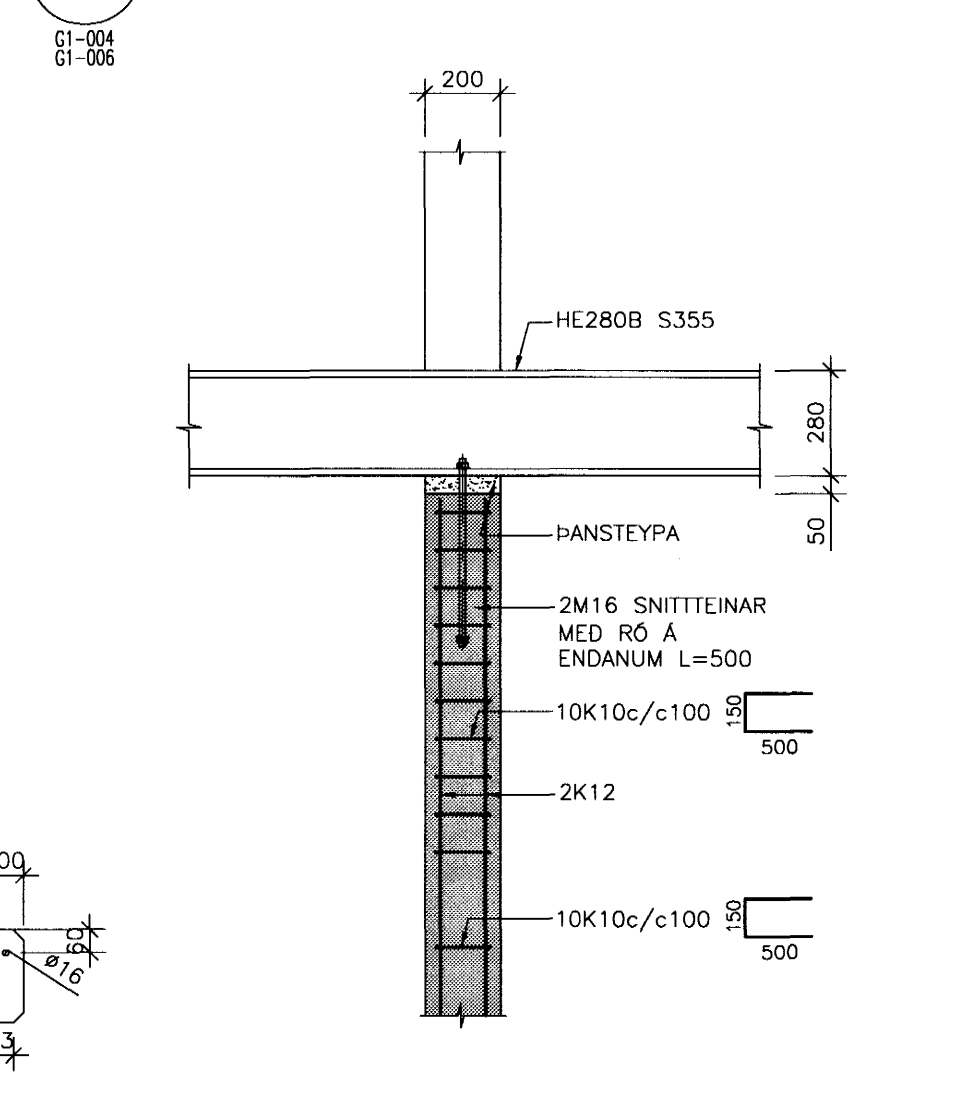

FESTING STÁLBITA MILLI 2 OG 3 VID GTFVEGG Í LÍNU F

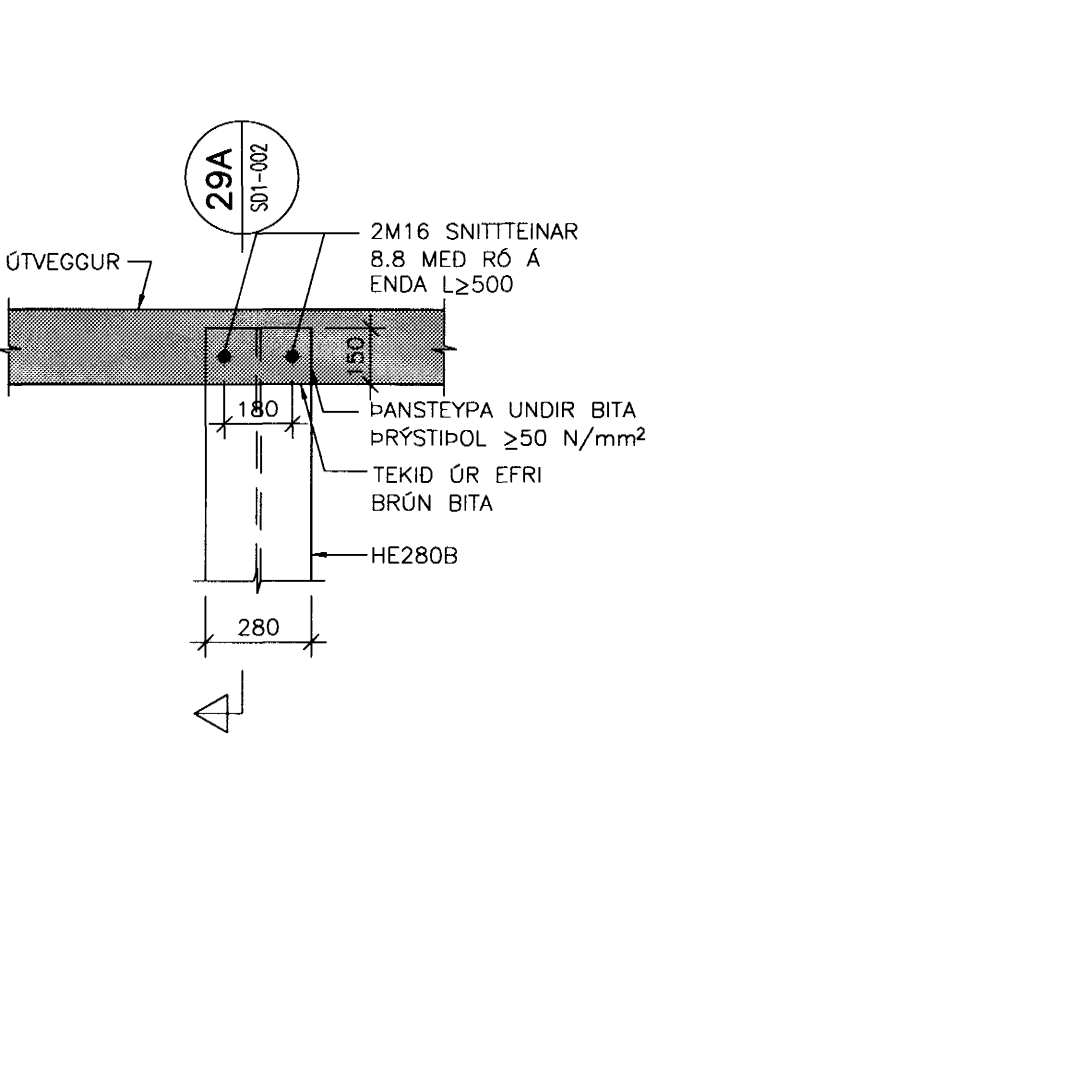

SM2 SÉRMYND 1:20

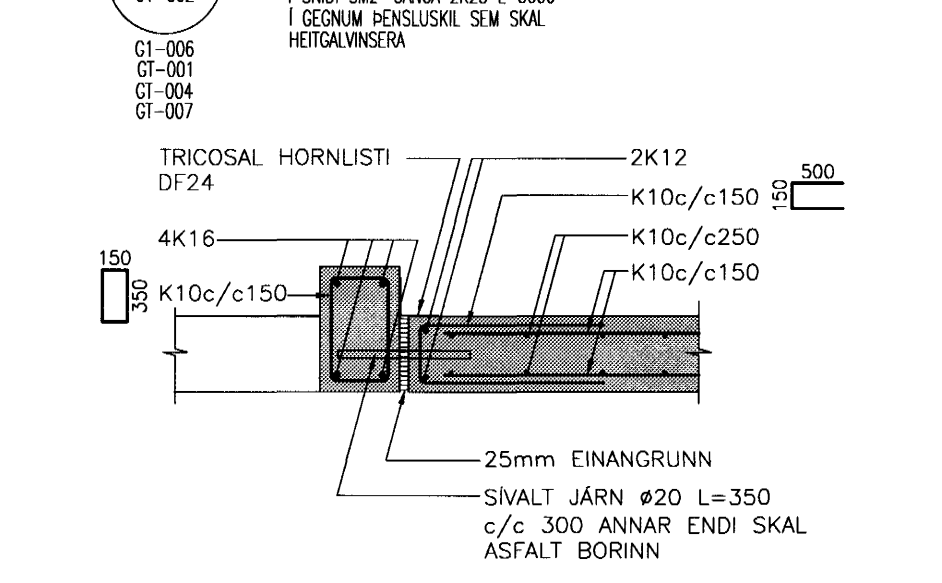

SM3 SÉRMYND 1:20

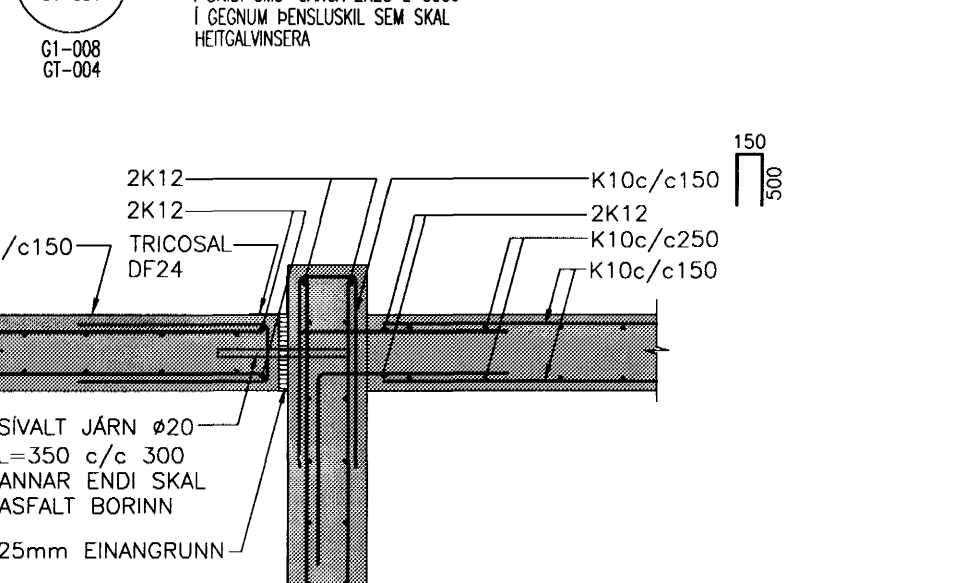

SM4 SÉRMYND 1:20

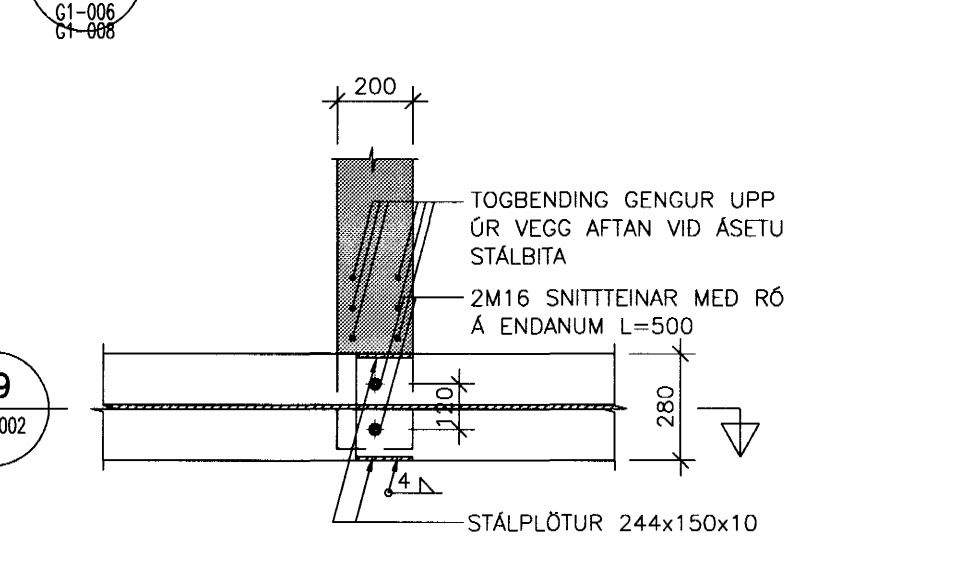

29A SNID 1:20

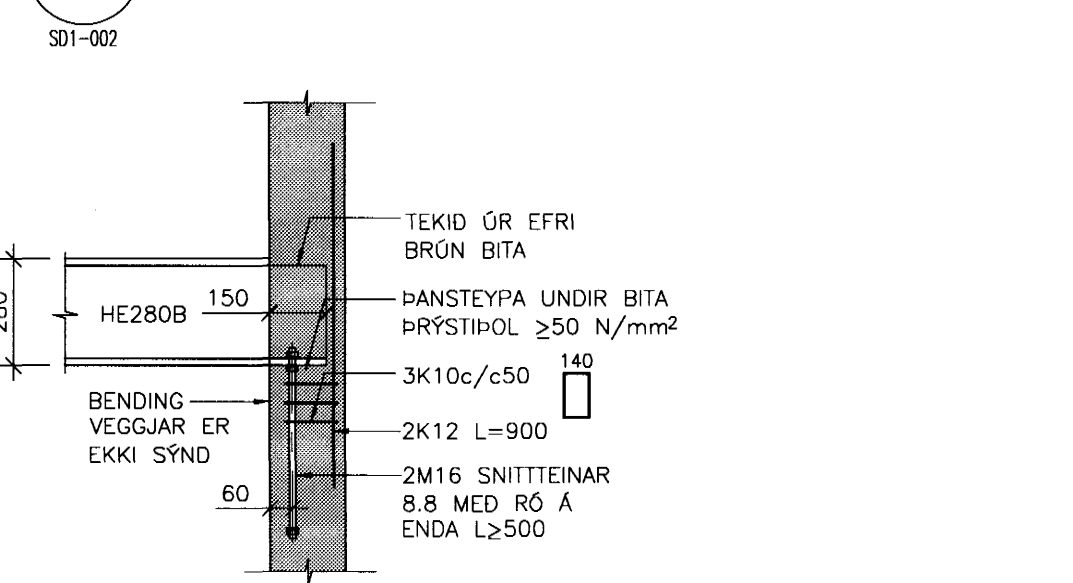

SKÝRINGAR: ÖLL MÁL ERU Í MM. ALLIR KÓTAR ERU Í M. ÚRTÖK Í STEYPU Í KRINGUM GLUGGA VEGNA ÍMÖRKERFIS SJÁ TEIKNINGU ARKITEKTA. TILVÍSANIR: ALMENNAR SKÝRINGAR SJÁ BL. NR. B2-B-VA-001

15/7/03 SC 071070-5069

Table with columns: BR. DAGS., BREYTING, REIKN., TEKN. and rows for different drawing versions.

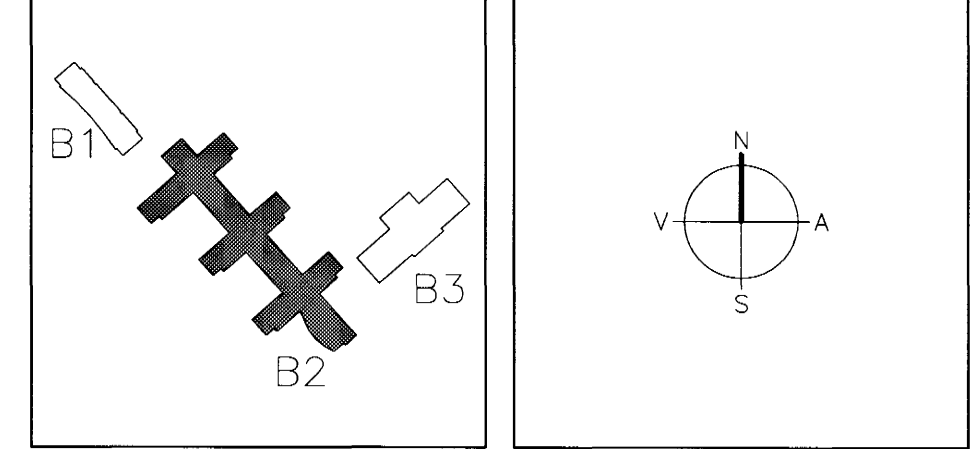

ARKITEKTAR BERGSTADASTRÆTI 10, RVK sími:551-1460, netfang:arkitekt@shot.is

EINAR E. SÆMUNDSEN INGBJÖRG KRISTJÁNSDÓTTIR MARGRÉT SIGURDARDÓTTIR

VSÓ RÁÐGJÖF SÓLVANGSVEGUR 4 LÆKJARSKÓLI

Bygginguvalturinn Hafnarfjarðar Algjett þann 15 AUG. 2003 VG

BURDARVIRKI PLATA YFIR 1.HÆÐ SNID OG DEILI