

Snið C1

Skýringar:
 Myndin sýnir bendingu kjallaraplötu.
 Brotin lína merkir járn í efri brún.
 ☉ Merkir plötupykkir
 Í horn koma mottur k12 c/c 150 stærð 2000x2000 (sérmerkt)
 Kótar eru í metrum ys. en málsetn í mm
 Steypa er s:250
 Mk: 1:50 á grunnmynd en 1:20 á sniðum

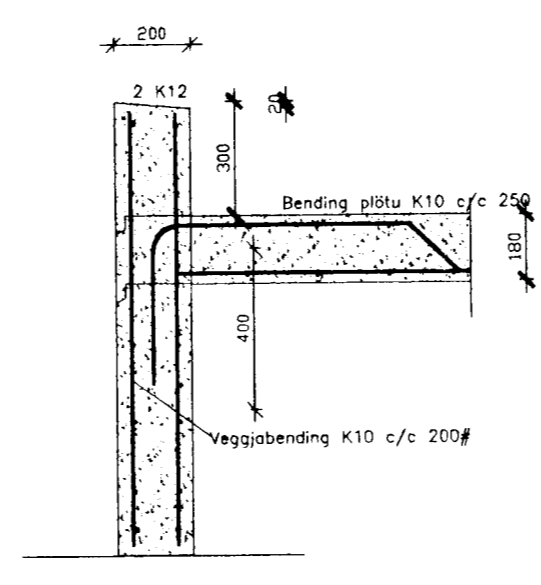

Snið C

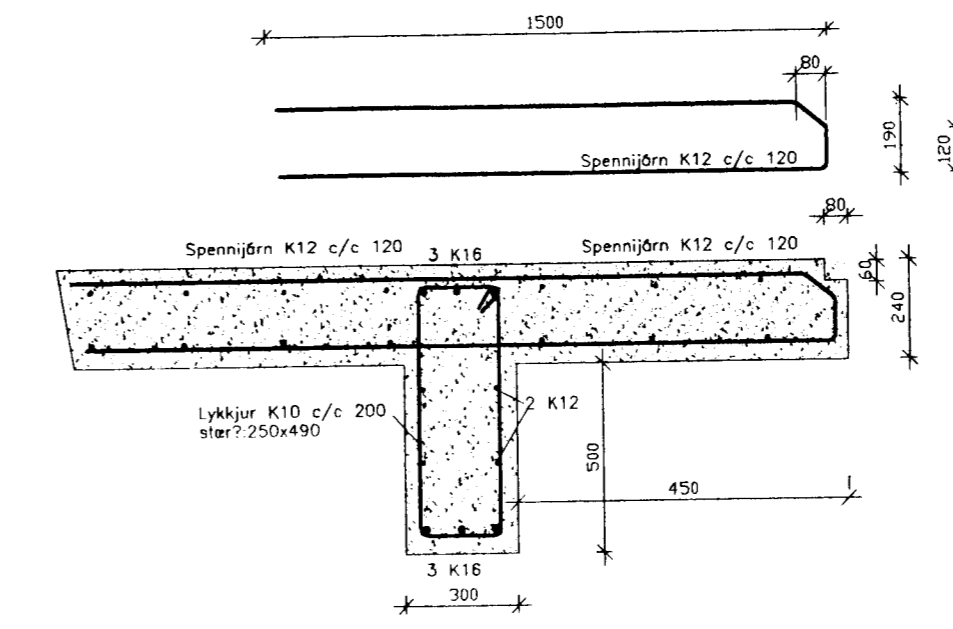

Snið B

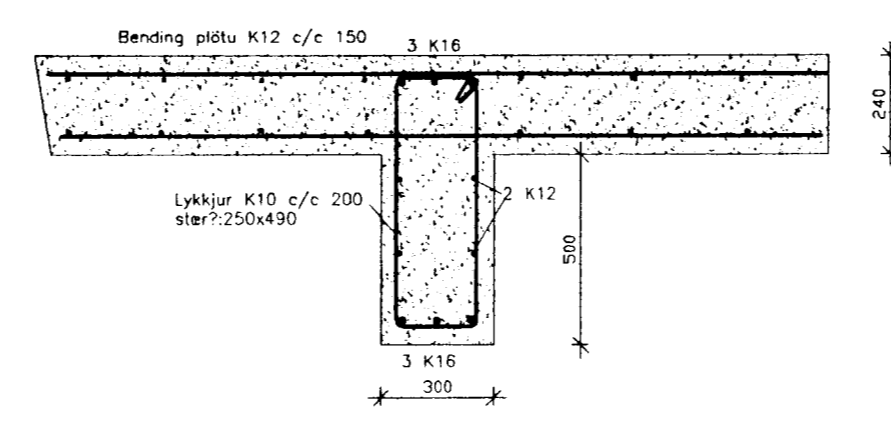

Snið D

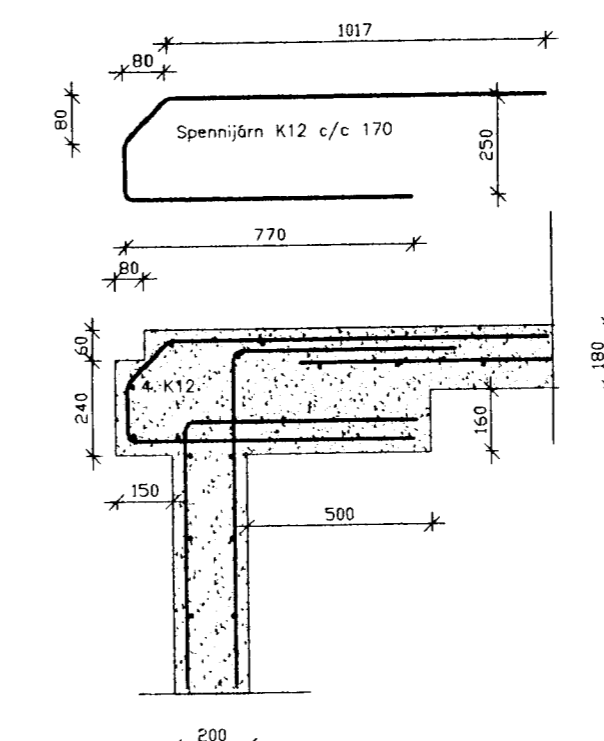

Snið A

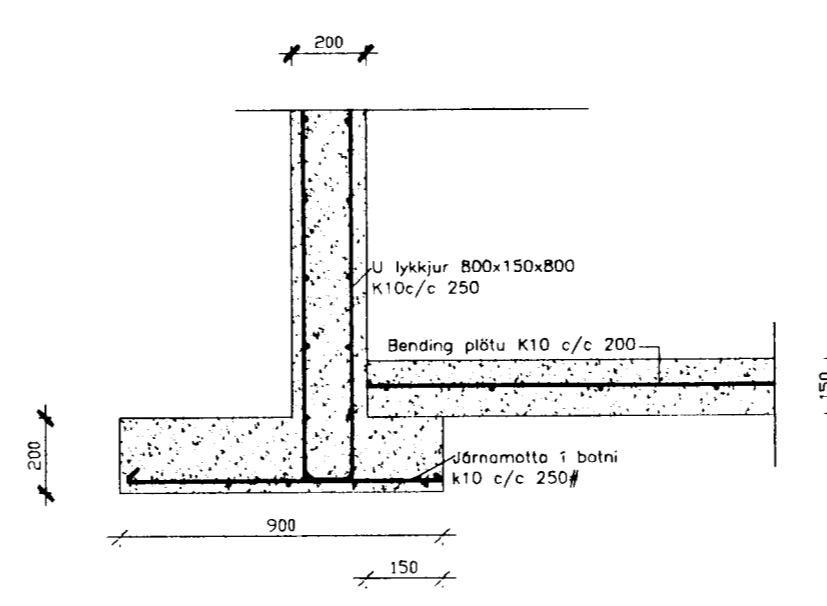

Snið E

Breytingar:	

Verkhli: Bending kjallaraplötu og snið	Teikn nr. Ís-05-03 Tölvu nr. Ís-05-03
Tilvísanir: Sjá teikn nr.:.....Ís-05-01 og 02	
Samþykkt þann 16 MAÍ 2001 Byggingafrádráttur í Hatnarfirði E. Sigurbjartur Halldórsson	

Verkefni Íshella 5 Hfj.	
TSÓ ehf Tækniþjónusta KT.601200-2440 Hrígateig 7 105 Reykjavík S:5533700,8997864,5812304 Fax:5533700 Netfang:tso@simnet.is	Mæliskvarðar: 1:50, 1:20
	Teiknað af: Sæma
	Dagsetning: Maí 2001
	Undirritaun <i>[Signature]</i>
Hannað: Sæmundur Óskarsson Byggingatæknifræðingur KT.180160-3109	