

**Snið 22-22**  
Mkv. 1 : 20

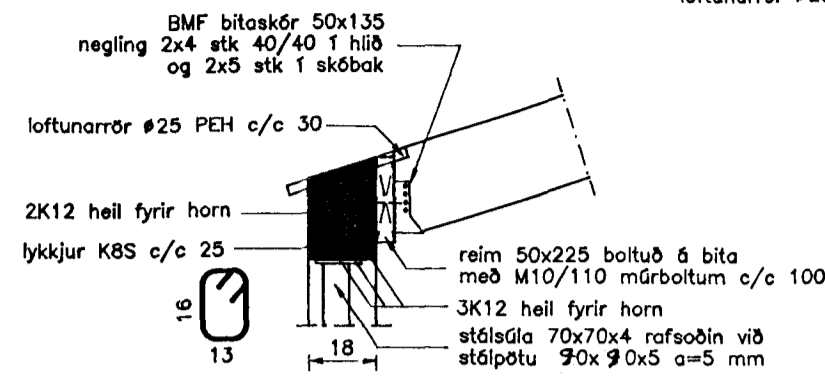

**Snið 23-23**  
Mkv. 1 : 20

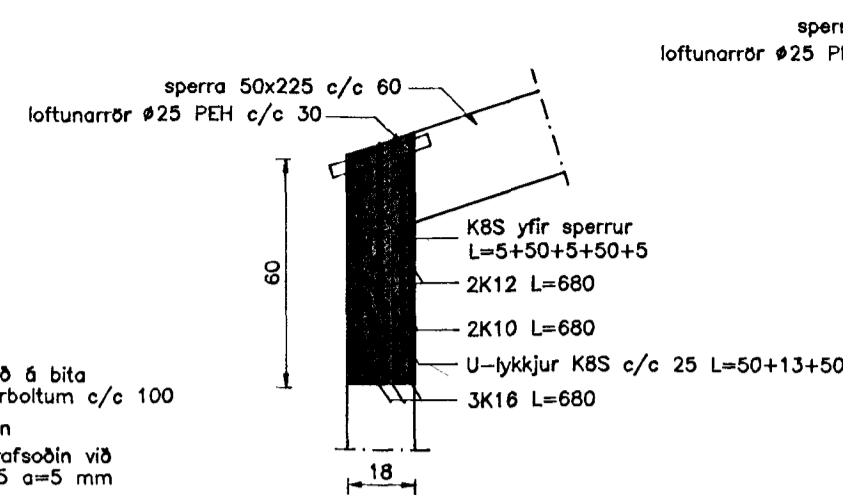

**Snið 24-24**  
Mkv. 1 : 20

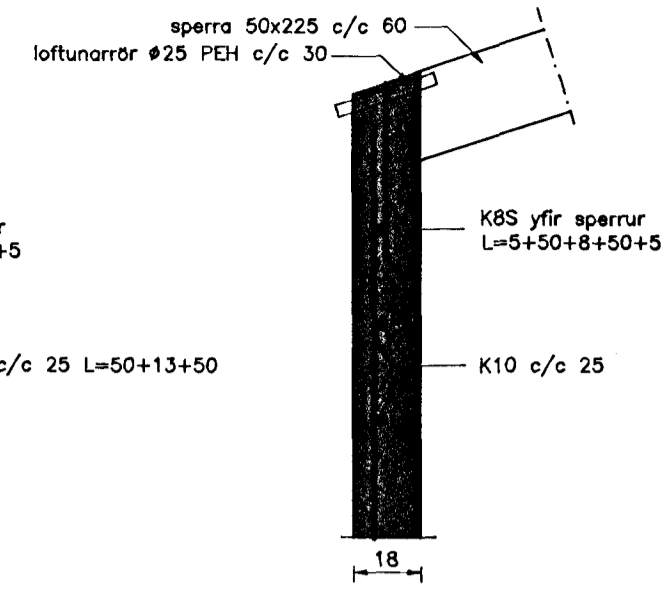

**Snið 25-25**  
Mkv. 1 : 20

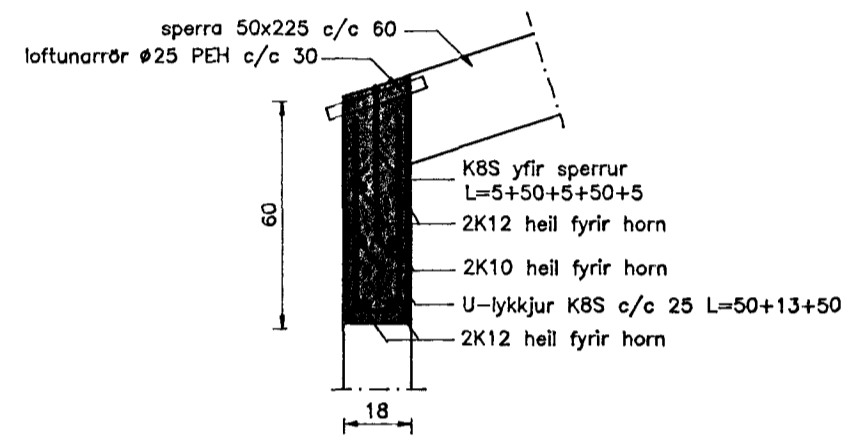

**Snið 26-26**  
Mkv. 1 : 20

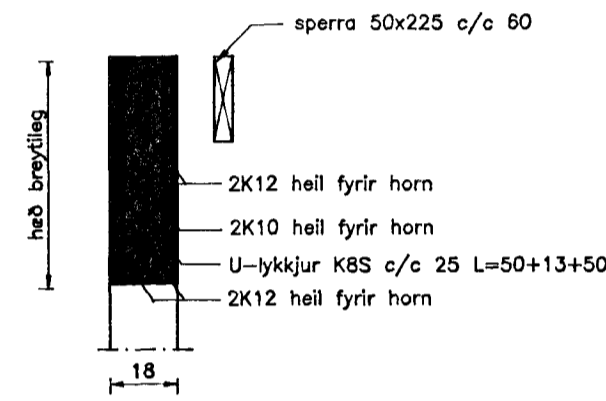

**Snið 27-27**  
Mkv. 1 : 20

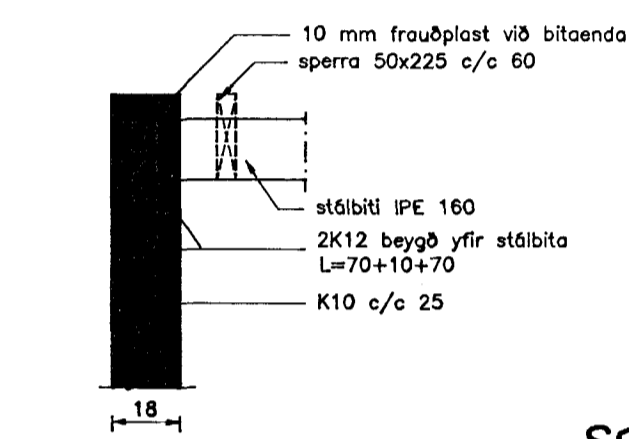

**Snið 28-28**  
Mkv. 1 : 20

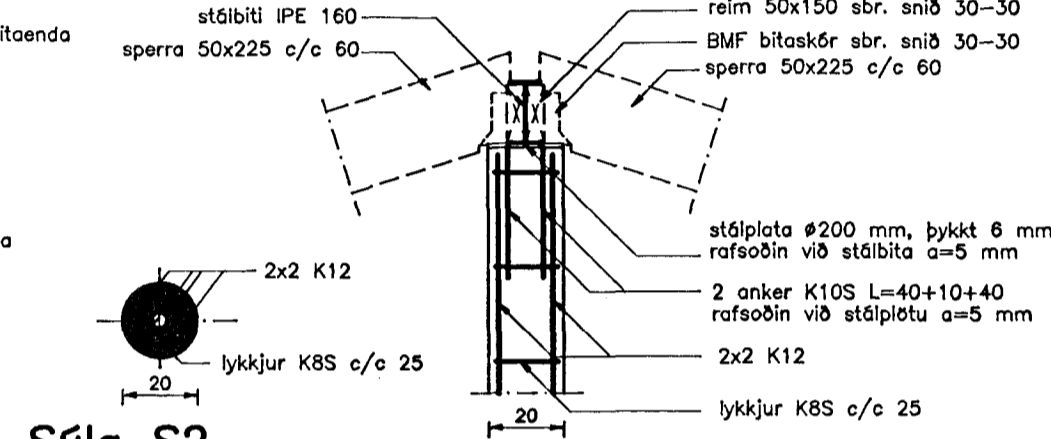

**Súla S2**  
Mkv. 1 : 20

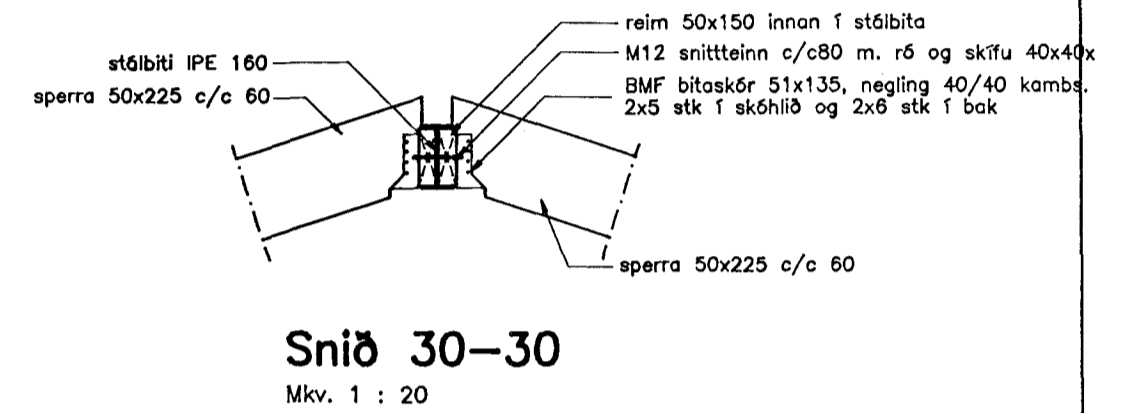

**Snið 30-30**  
Mkv. 1 : 20

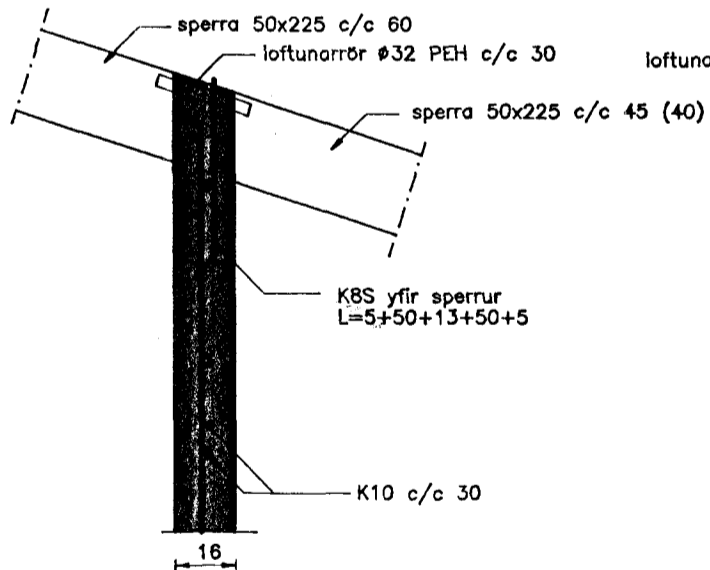

**Snið 31-31**  
Mkv. 1 : 20

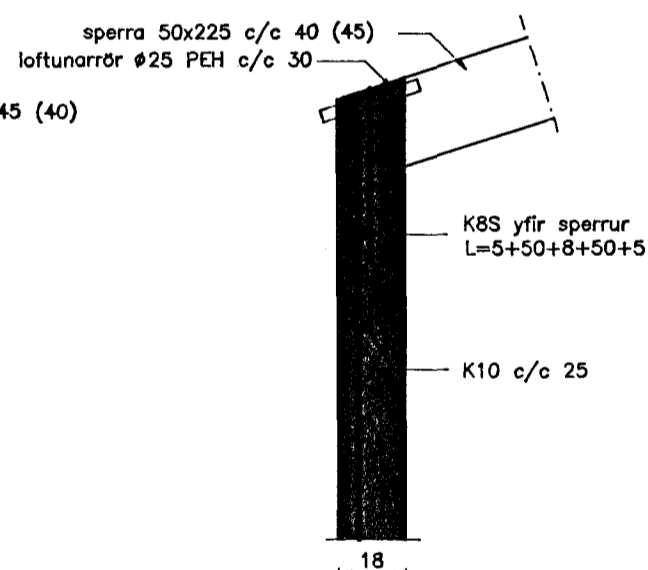

**Snið 32-32**  
Mkv. 1 : 20

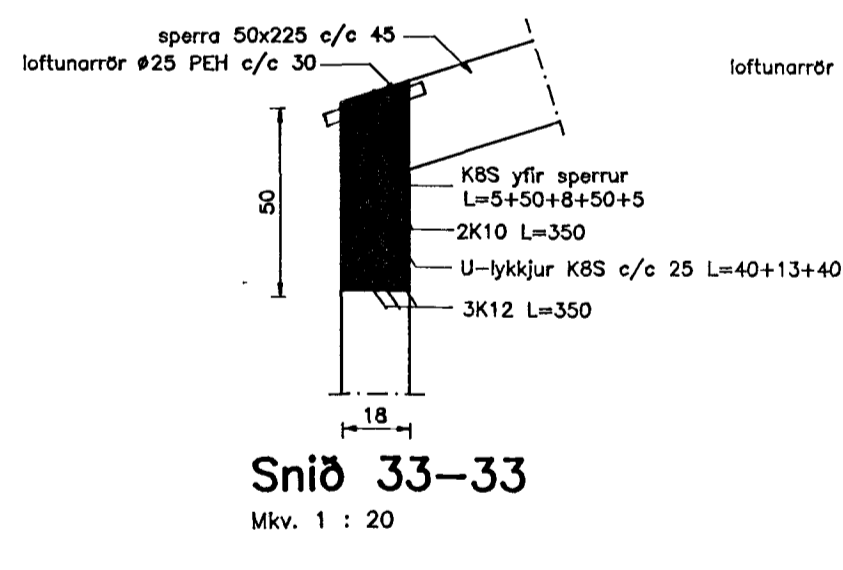

**Snið 33-33**  
Mkv. 1 : 20

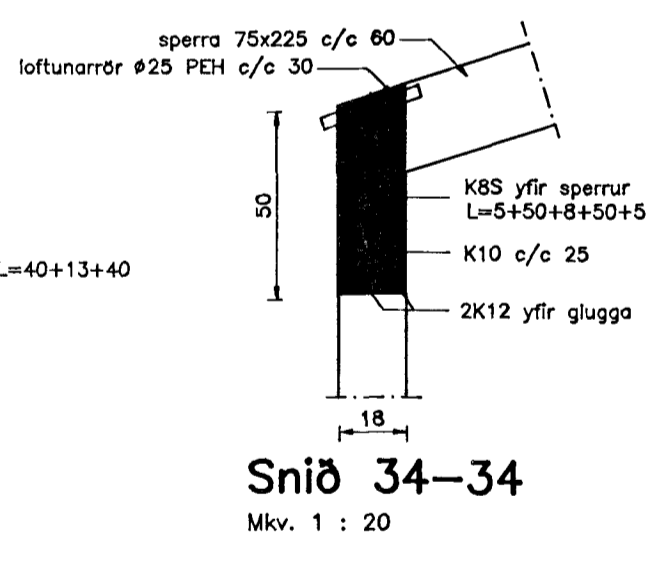

**Snið 34-34**  
Mkv. 1 : 20

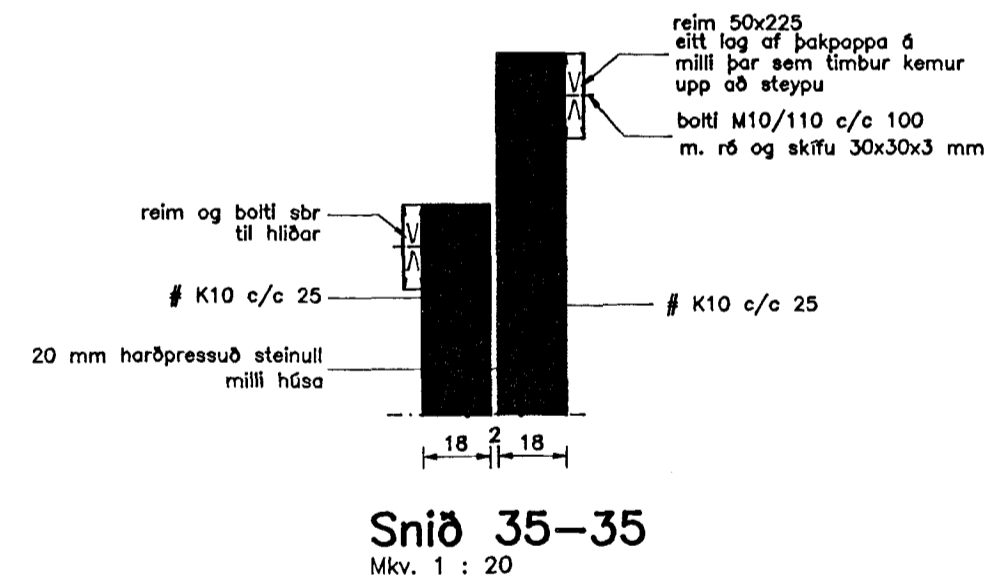

**Snið 35-35**  
Mkv. 1 : 20

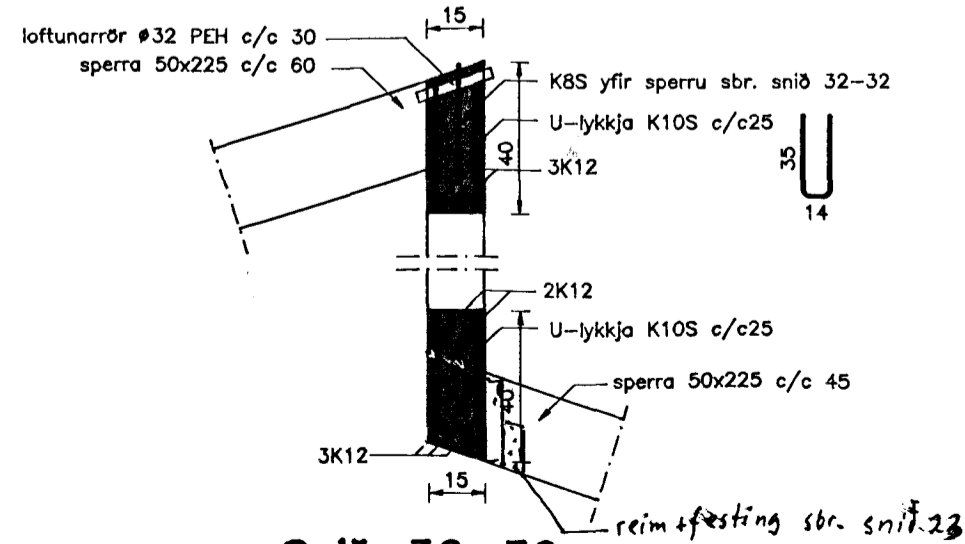

**Snið 36-36**  
Mkv. 1 : 20

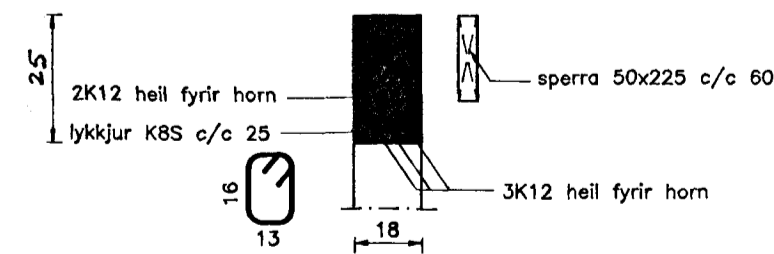

**Snið 22a-22a**  
Mkv. 1 : 20

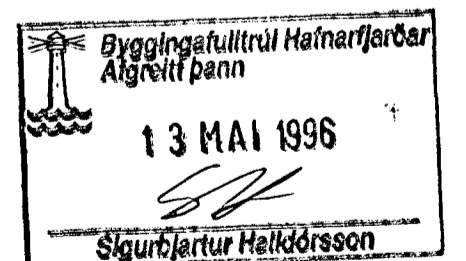

**TEIKNISTOFAN TORGIÐ**  
RÁÐGJÖF - HÖNNUN - EFTIRLIT  
ARNÓLI 36, 108 REYKJAVÍK, Sími 568-8866, FAX 568-8878  
Porsteinn Friðbjörnsson, Mognás P. Guðmundsson, byggingateknifráðingur, Innviðisvorkerfi.

VERK:	Lindarberg 80-82 Hafnarfirði
TEIKNING:	Snið 1 burðarvirki
TEIKN. NR.:	606
DAGS:	12.11.95.
BREYTT:	B
KVARD:	1:20
VERK NR.:	95-804 HANNAÐ: ÞF

B: 08.05.96. Smávægil. br. á sniðum.  
A: 03.05.96. Smávægil. br. á sniðum.