

Snið A, 1:20

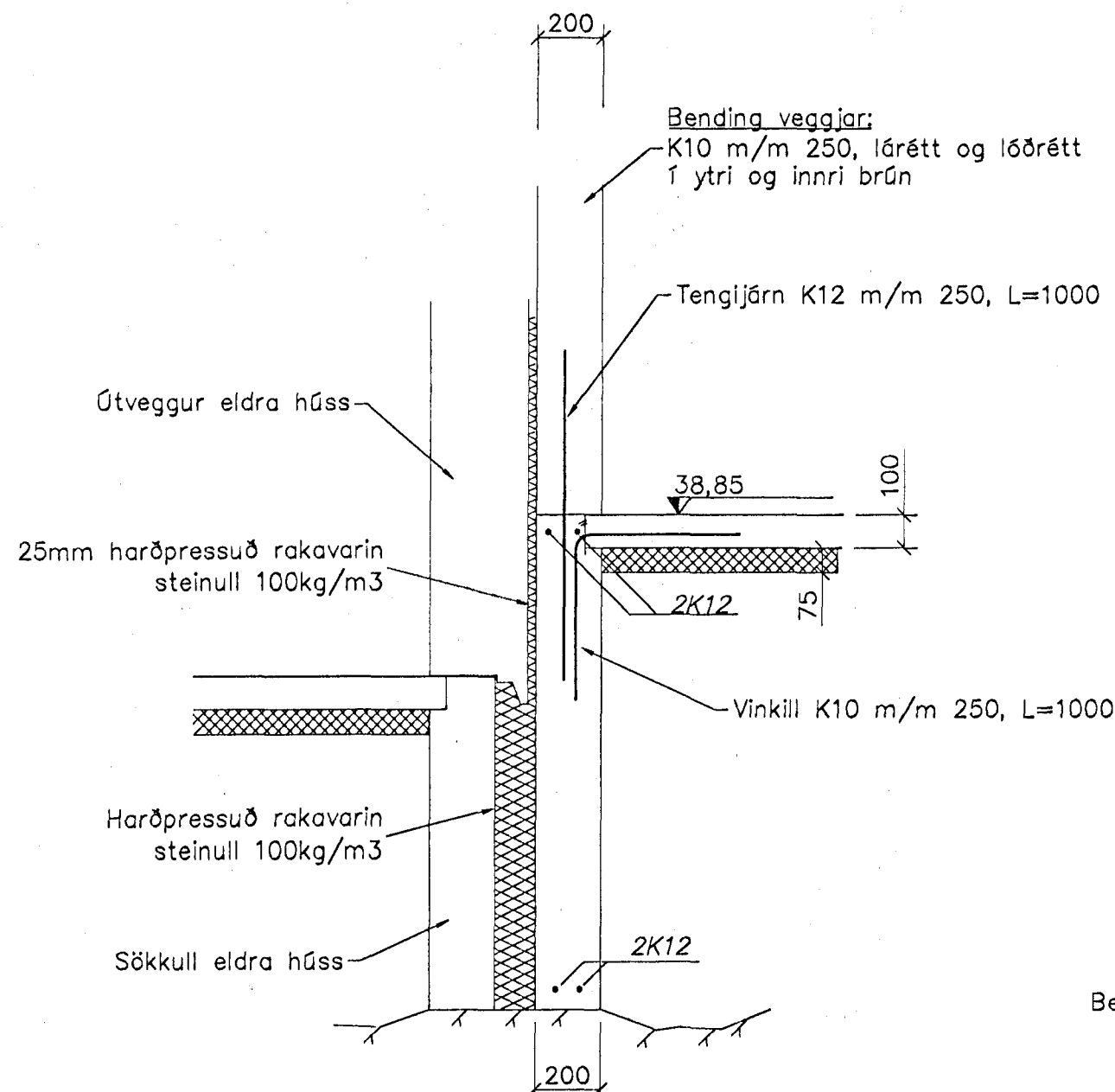

Snið E, 1:20

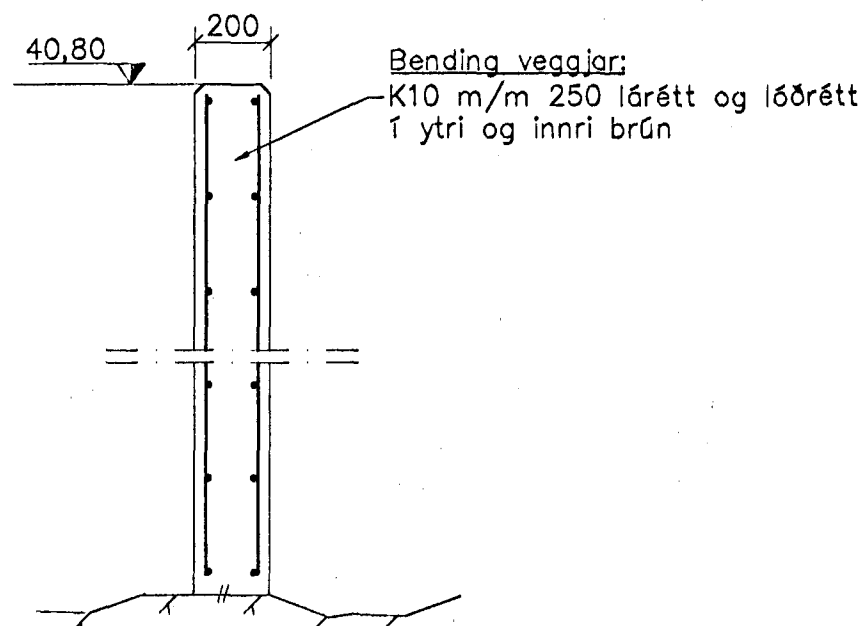

Snið J, 1:20

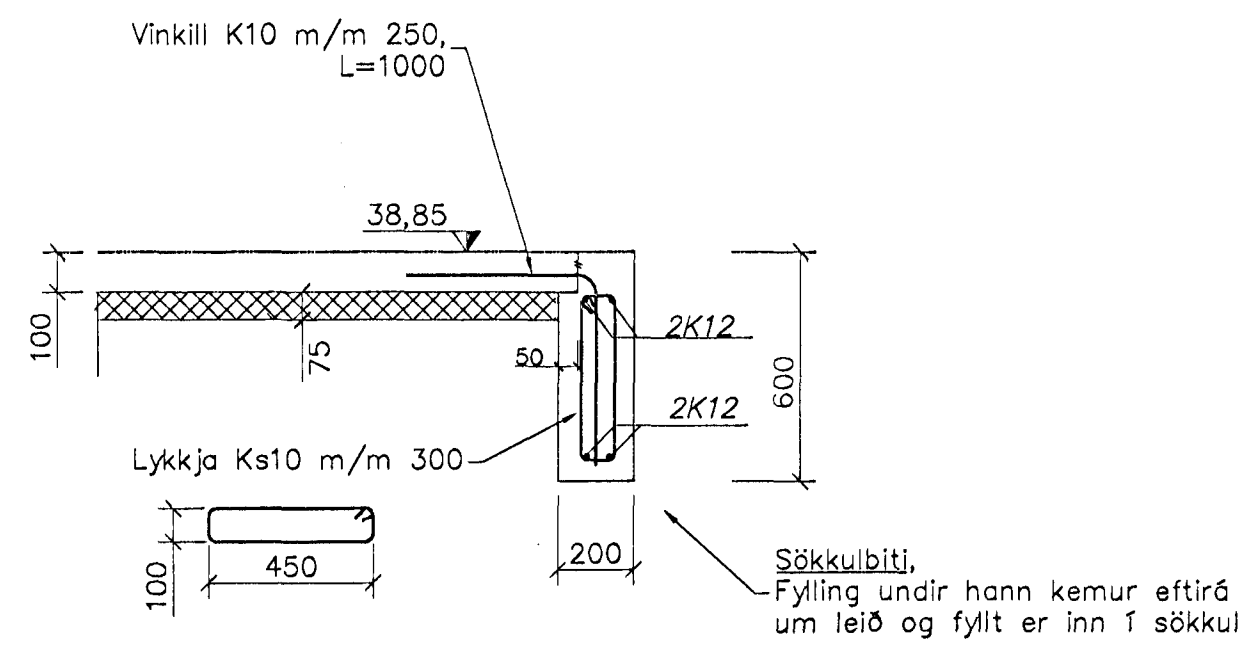

Snið B, 1:20

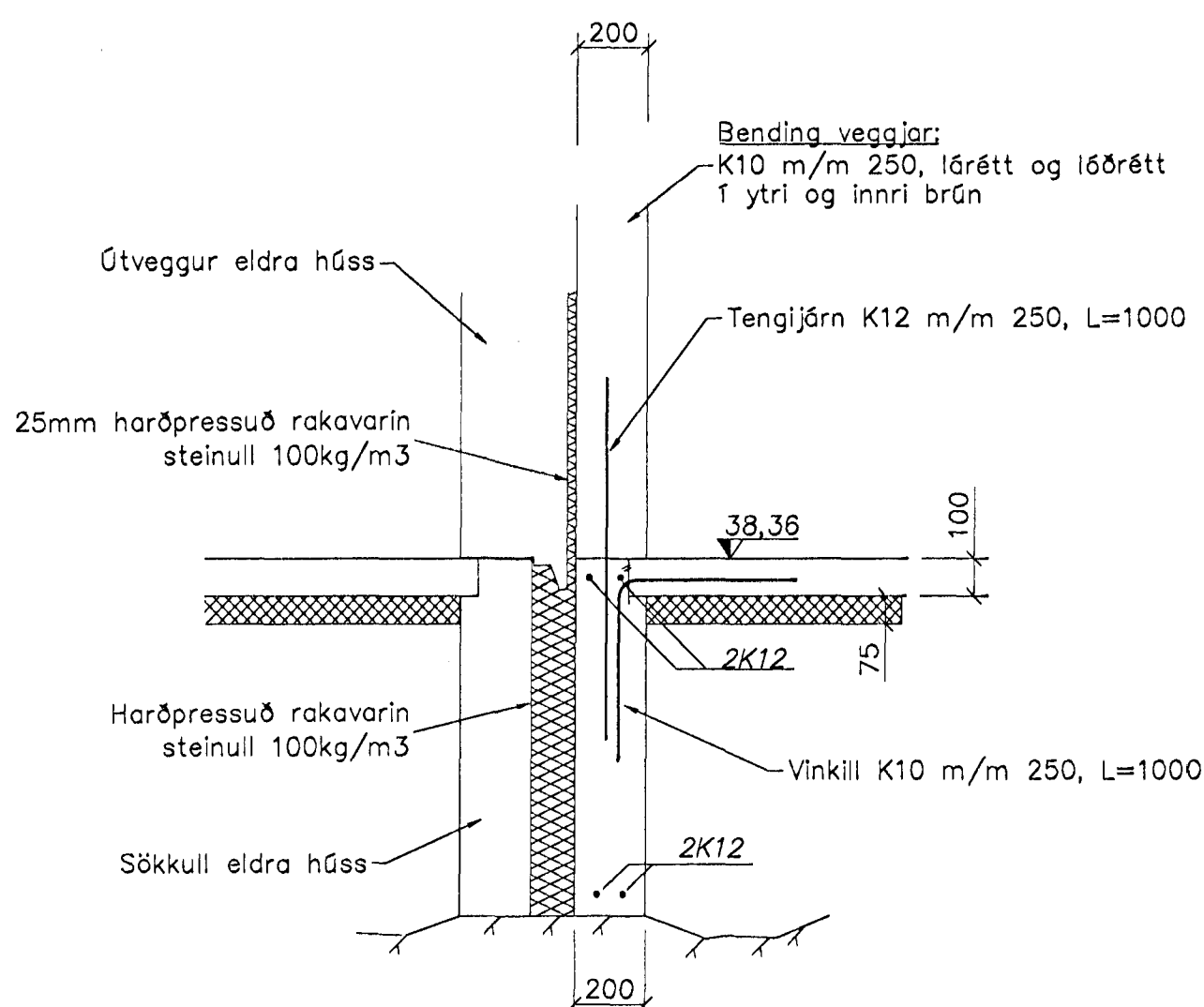

Snið F, 1:20

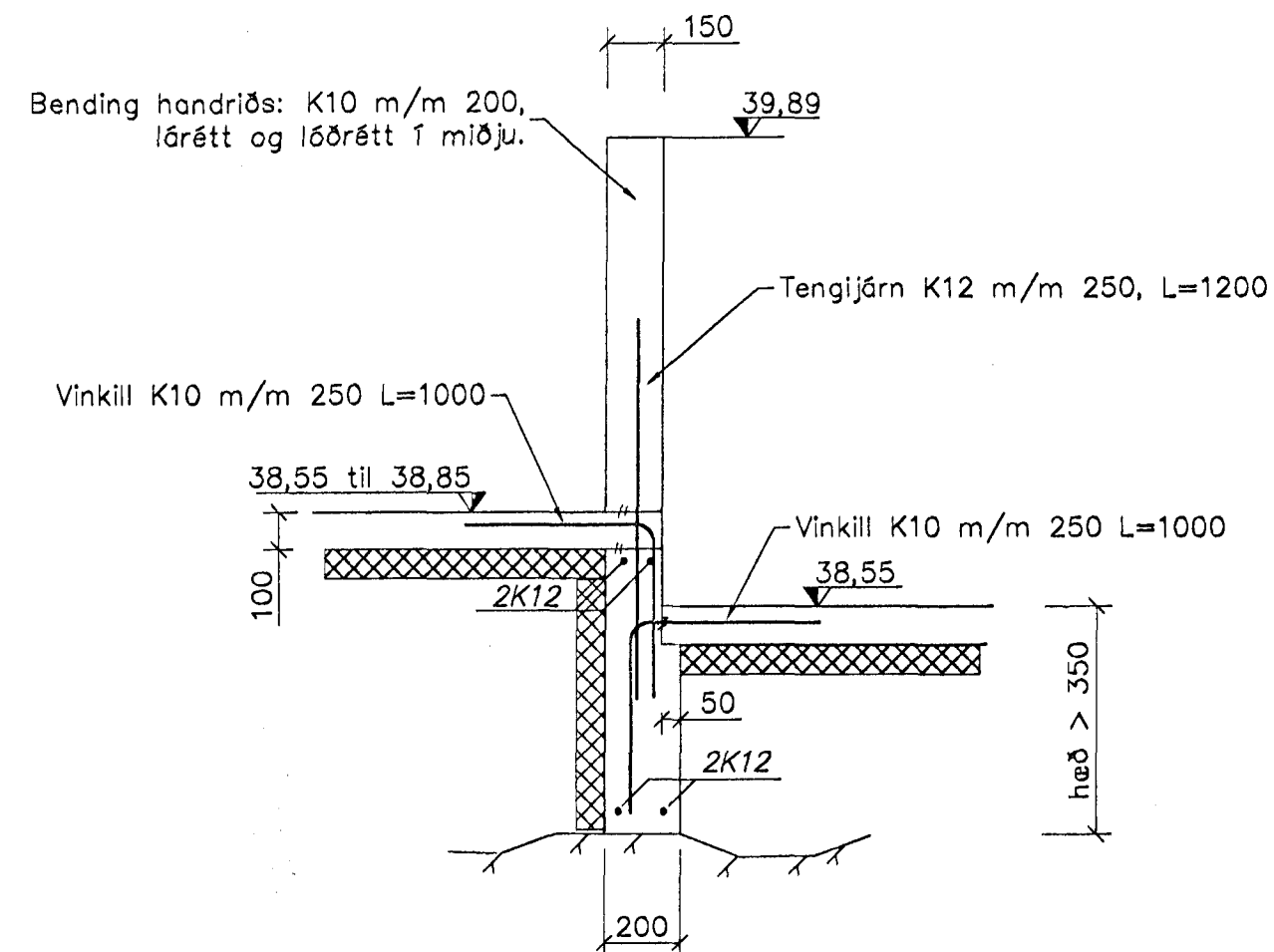

Snið I, 1:20

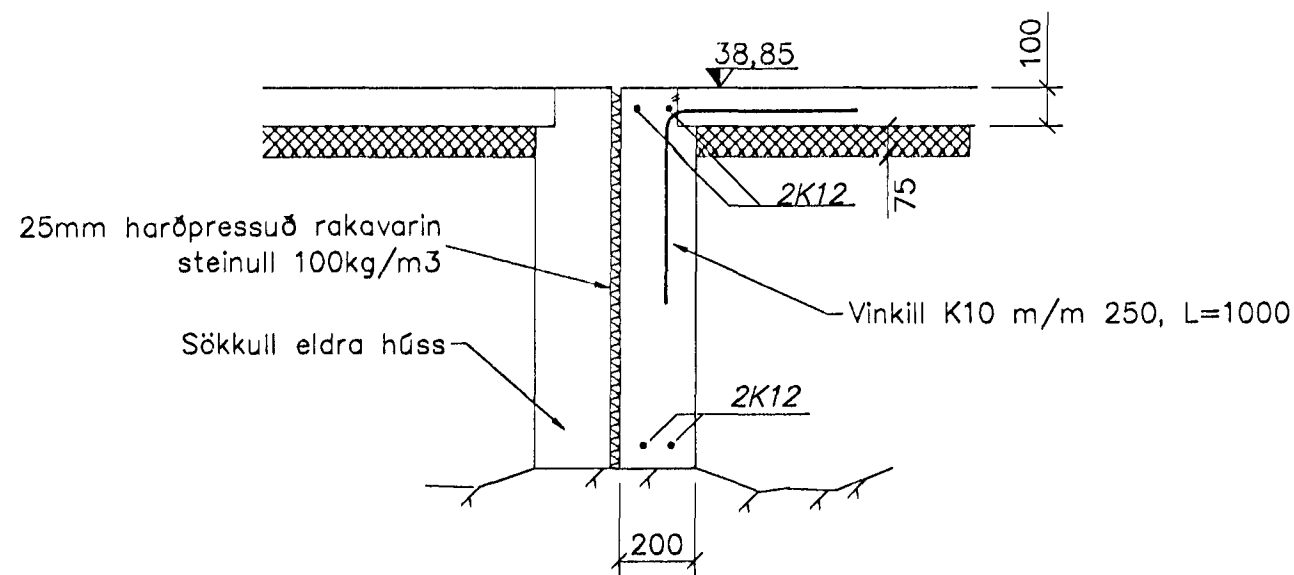

Snið C, 1:20

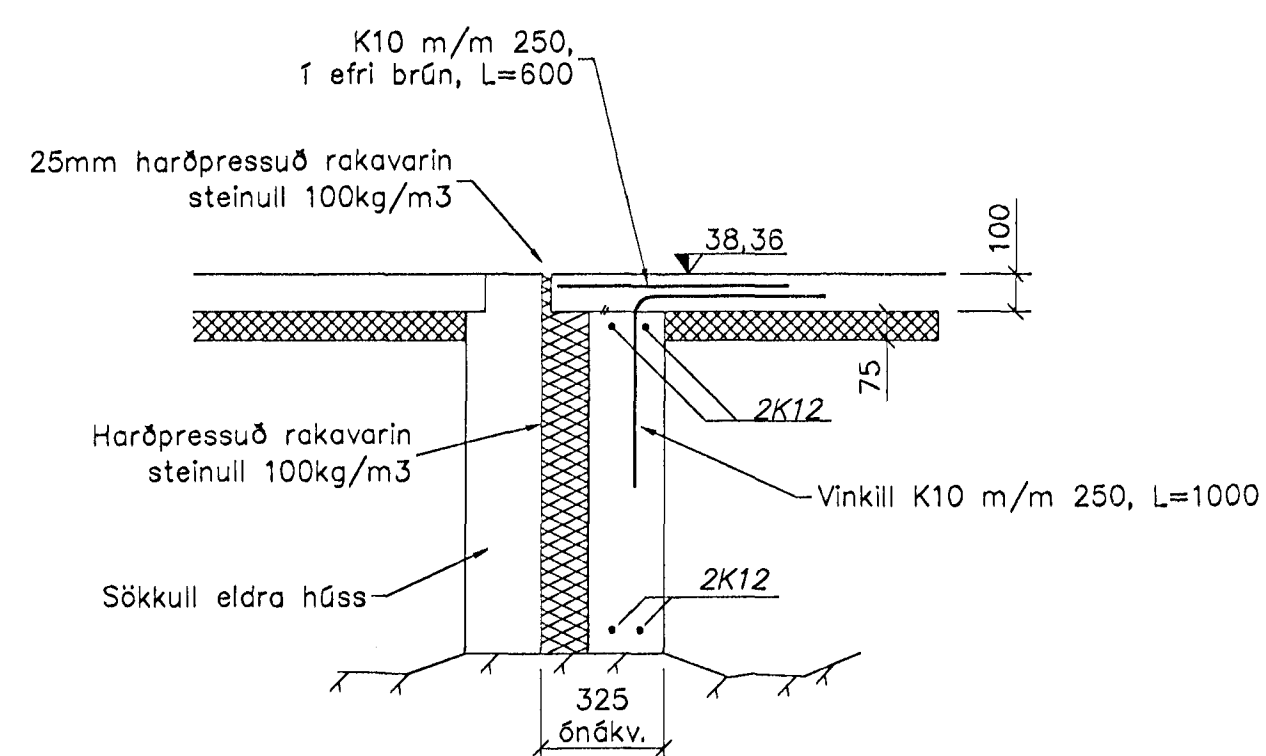

Snið G, 1:20

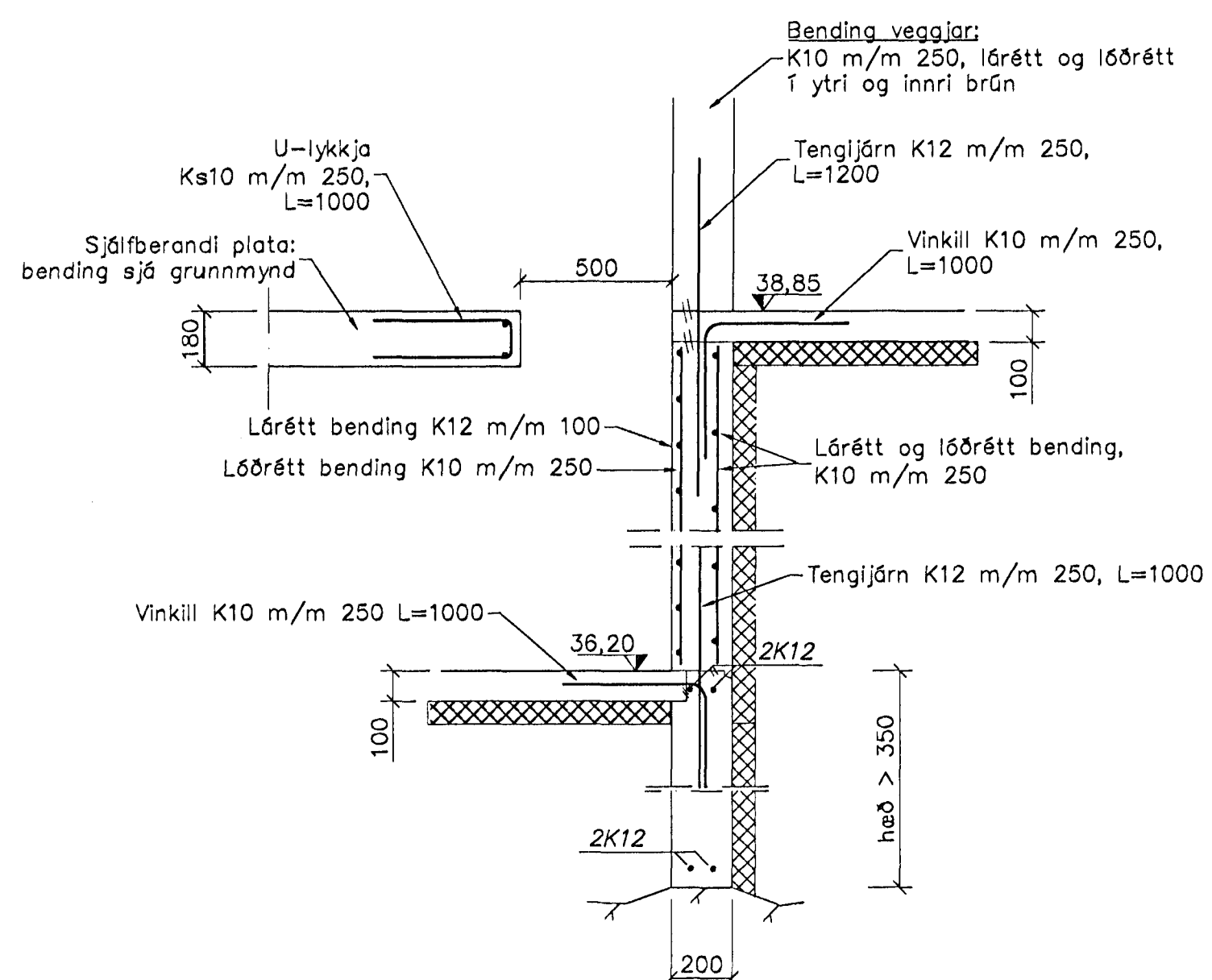

Snið K, 1:20

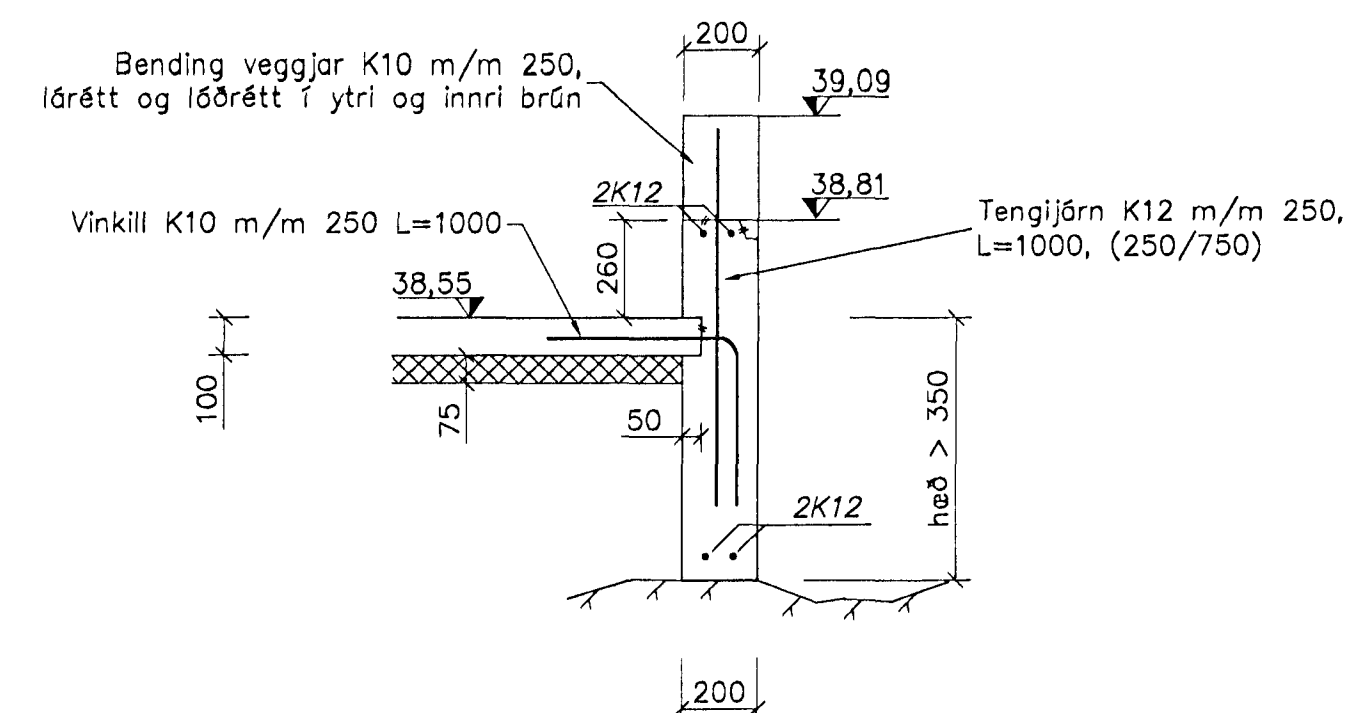

Snið D, 1:20

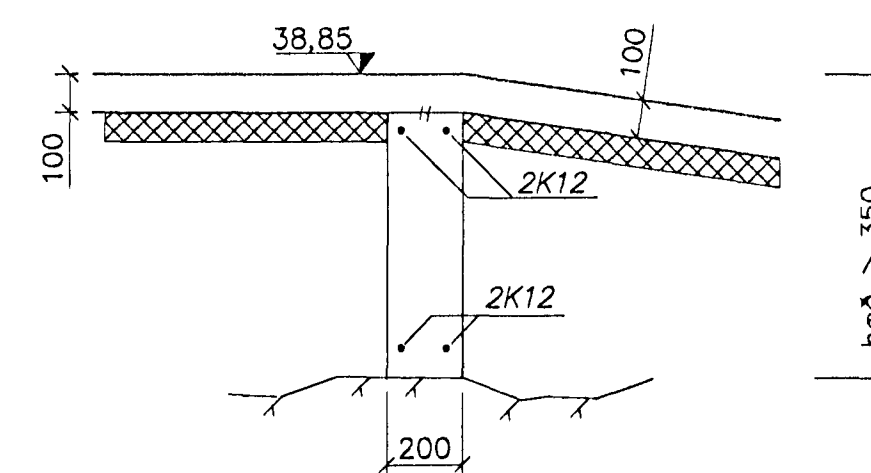

Snið H, 1:20

Skýringar:

Öll mál eru millimetrar [mm], en hæðarkótar eru í metrum [m].
 Á milli botnplötu og einangrunar kemur 0,2mm pólplast sem skal skarast um 400mm á samskeytum.
 Einangrun undir botnplötu skal vera 75mm "polystyren" einangrun (25-30 kg/m³).
 Botnplata er járnþent með K189 bendinetti í miðja plötu.
 Frekari skýringar sjá teikningu nr. HB03-100.

Byggingafulltrúi Hafnarfjarða-
 Afgreitt þann
 22. DES. 1997
 Sigurbjartur Halldórsson
 10. des. 1997

VINNUTEIKNING

E-Strendingur ehf.		Einsetning Óludátunsskóla	
Vestfirðisbúnaðar- Ráðgjafingur 14-15 Hafnarfjarður 4100 Reykjavík, Sími 590 1000		1. áfangi - viðbygging	
brýgning	nafn	Sökkjar, snið	
höfundur	HBM	des. 1997	
teiknari	HBM	des. 1997	
hlutverk	012/1997	dagsetning	des. 1997
	Hallgrímur Halldórsson	teikn. nr.	HB03-107
		málkvæði	1:20
			A1

1 2 3 4 5 M