

DEILI 3

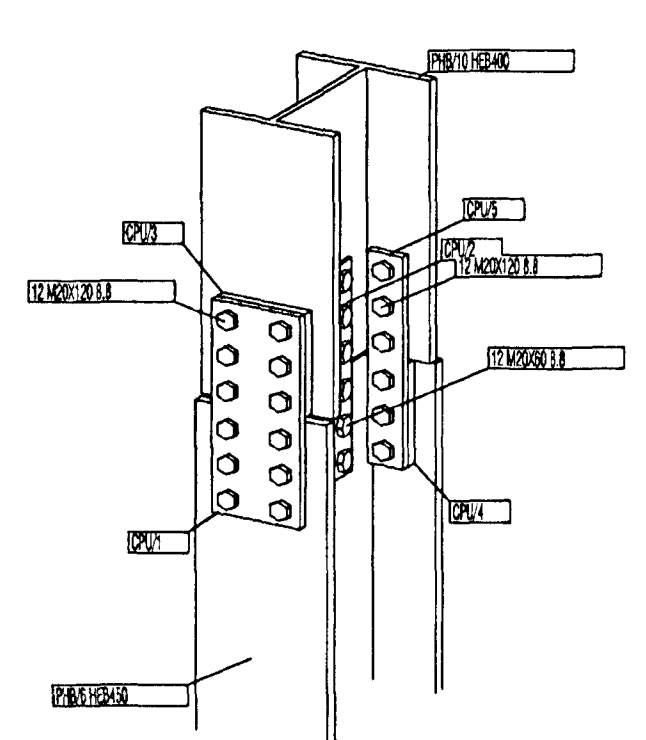

DEILI 1

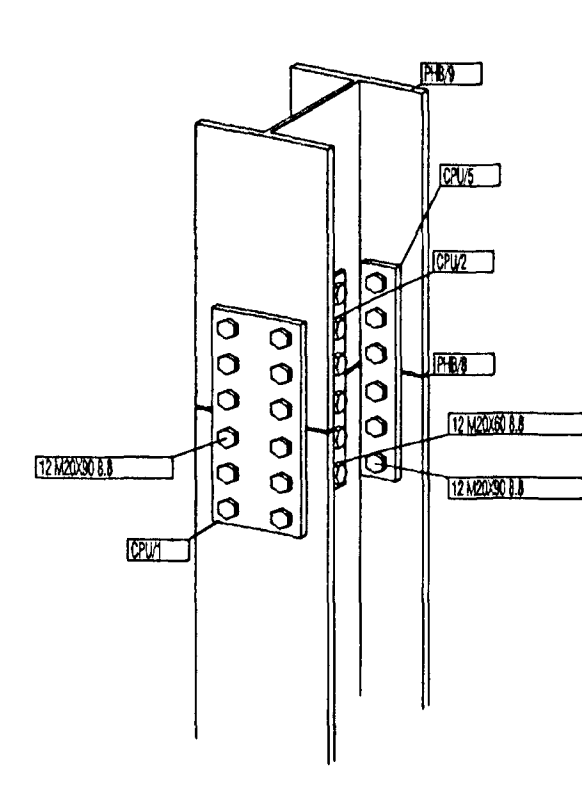

DEILI 2

# stöð	styrkur torque Mo (m.Kp.)		
	8.8	10.9	12.9
M12	9.46	13.20	15.95
M16	23.10	31.90	39.05
M20	45.10	63.90	78.90
M22	60.50	85.80	102.30
M24	78.10	110.00	132.00
M27	115.50	165.00	198.00
M30	159.50	220.00	264.00

COPERFIL®
GROUP

VEKTOR -hönnun og ráðgjöf- Nýbýlavegi 6, 200 Kópavogur.		Sigurður Halsteinsson byggingafræðingur Kl. 000809-7748 símt 554-8650 fax 554-8688		Óseyrarbraut 40 Skipaskáli Rúmmynd	
Telín. nr.	Tilvisun á teikningu	By.	Dag.	Hinnar	Teknað
Sambýxt	<i>Sigurður Halsteinsson</i>			SH	KR
Dagsetning	Vert nr.	Málkvarði	Telín. nr.		
Ágúst 1999	S850	1:100	S850P2P		