

Vísad: 7.2.2023 14:52:00	Óprentur: 07.02.2023		
Útg. A	Dags. 07.02.2023	Skýring	Br.afi. Yfir. ISO BJP

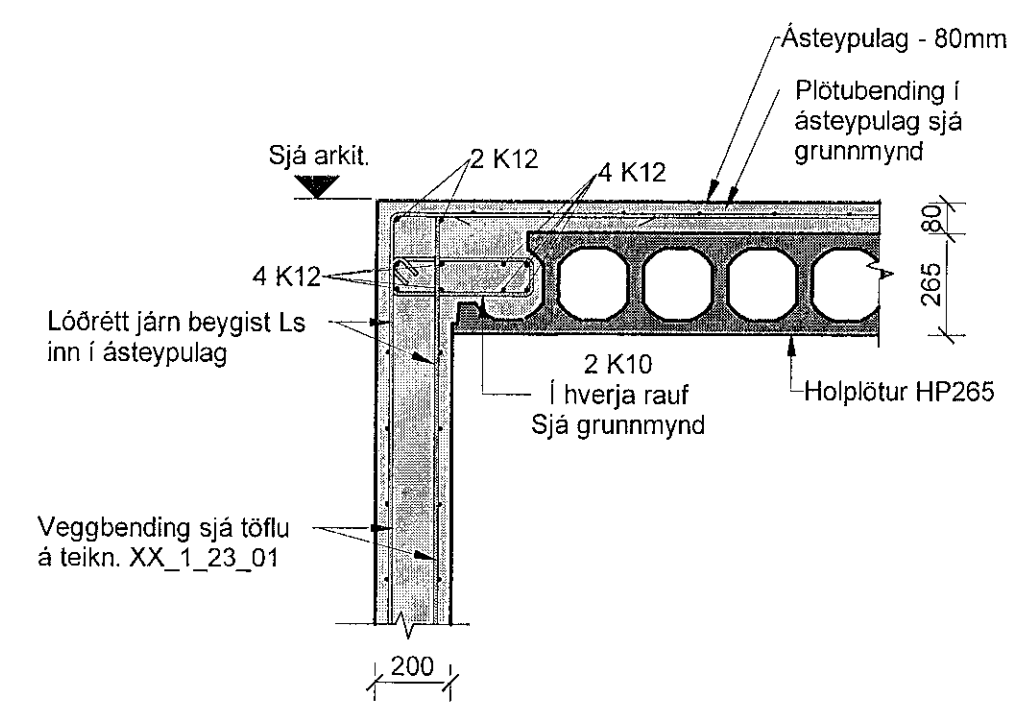

EA Snið EA
01.121.01 1 : 20

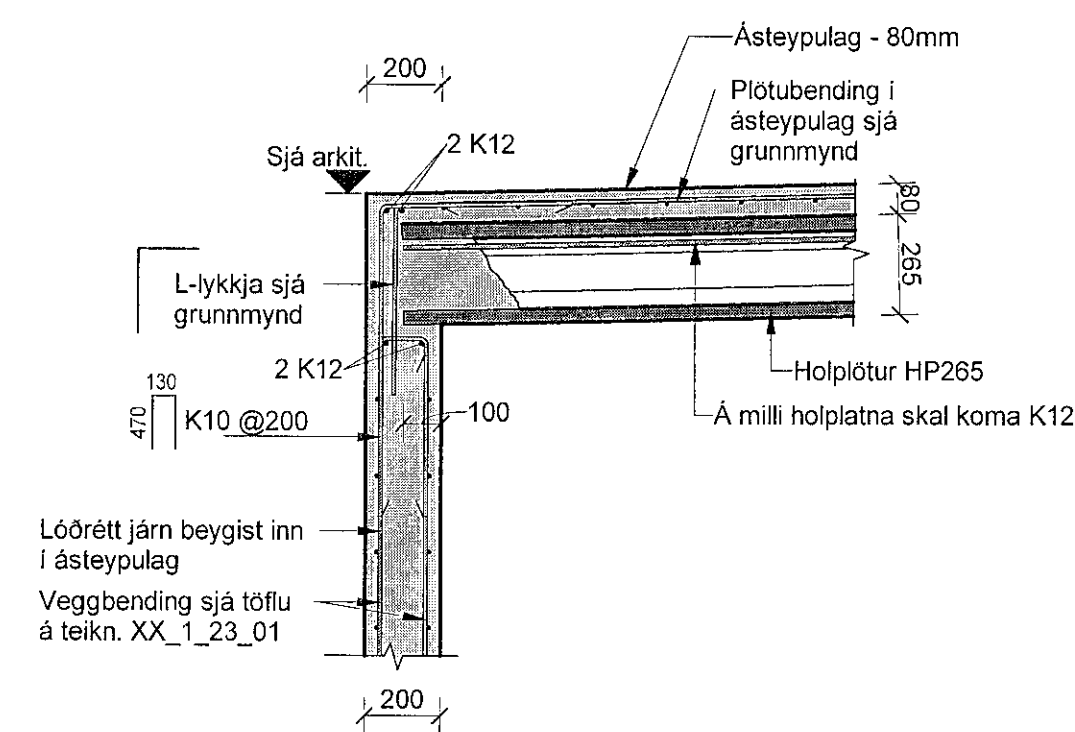

EB Snið EB
01.121.01 1 : 20

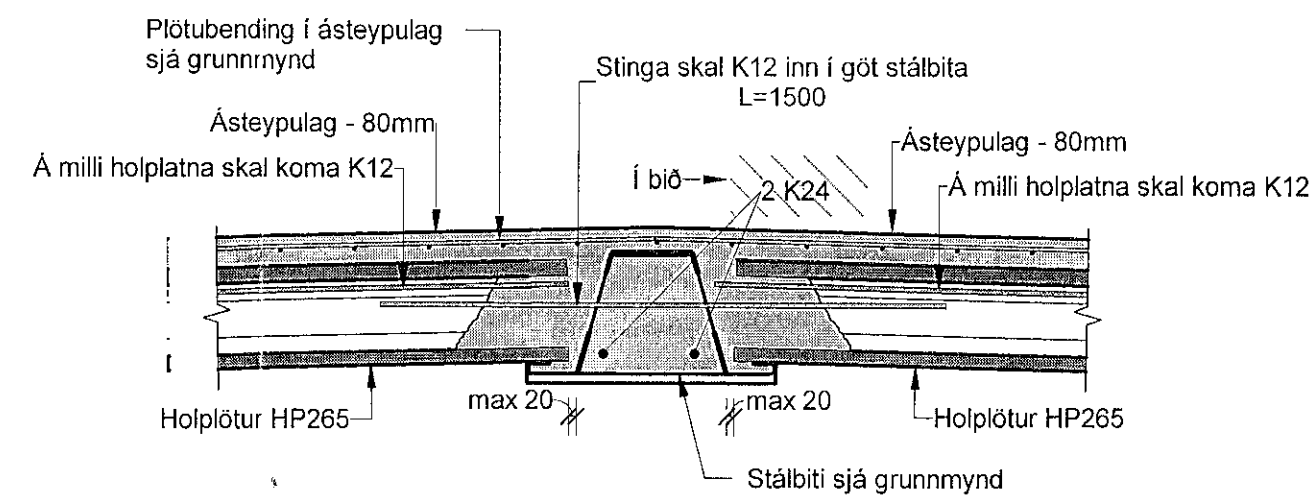

EC Snið EC
01.121.01 1 : 20

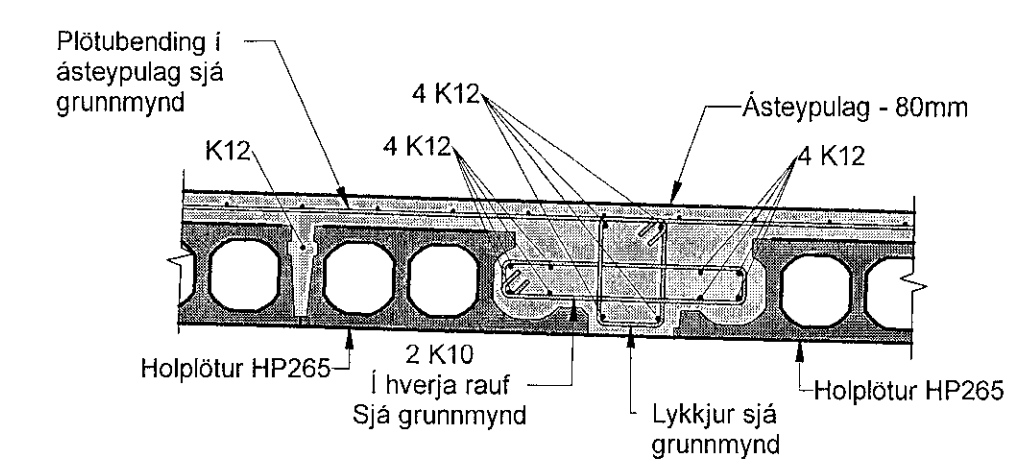

EG Snið EG
01.121.01 1 : 20

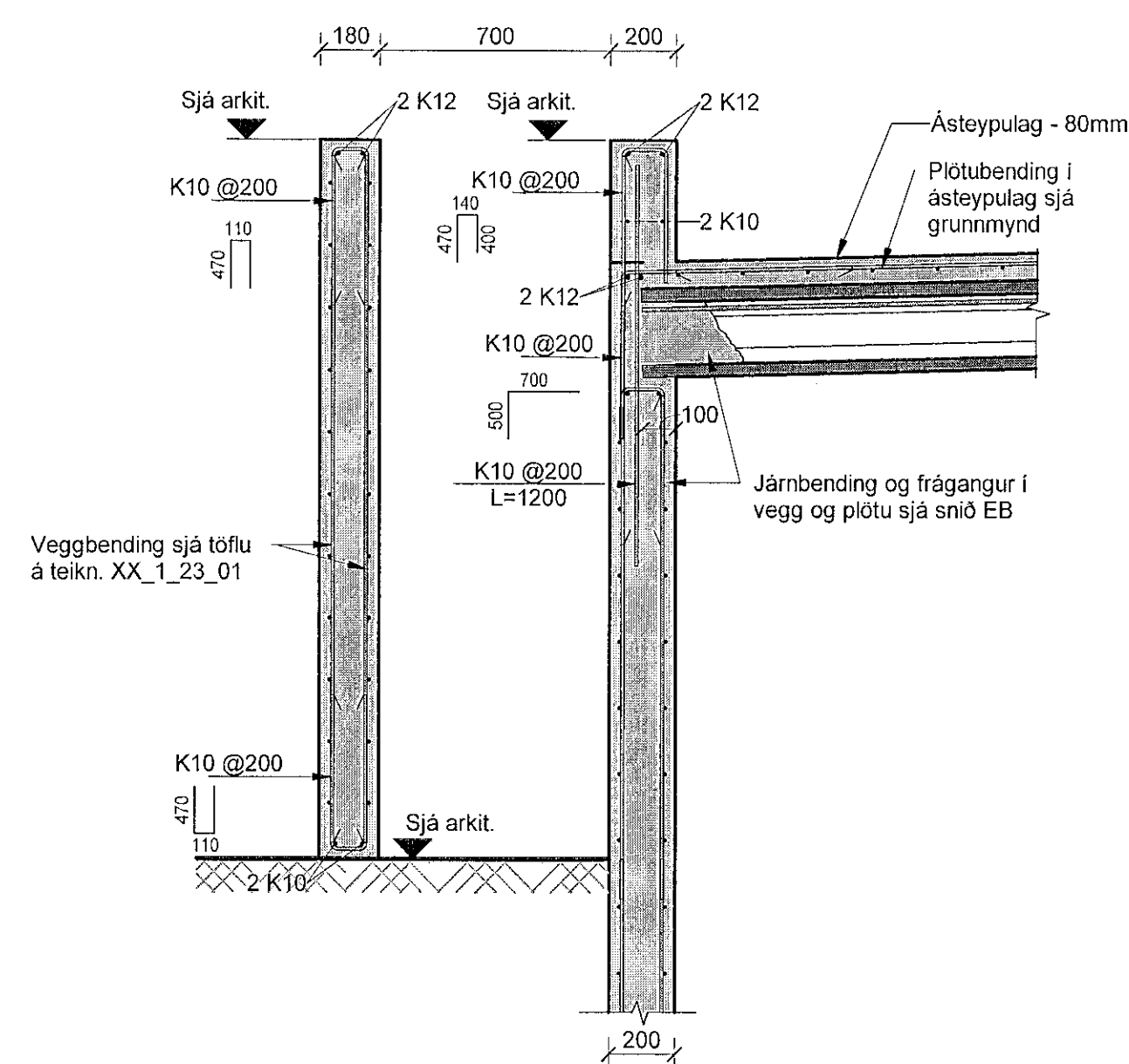

EF Snið EF
00.121.04 1 : 20

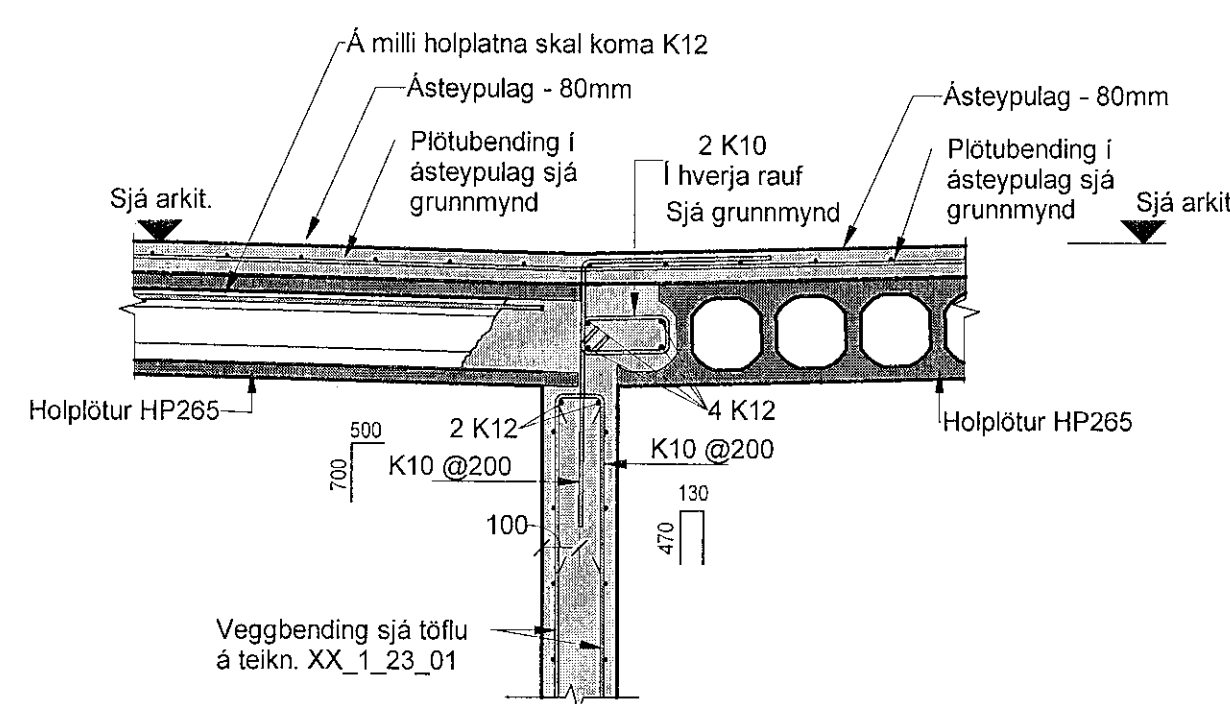

EI Snið EI
01.121.03 1 : 20

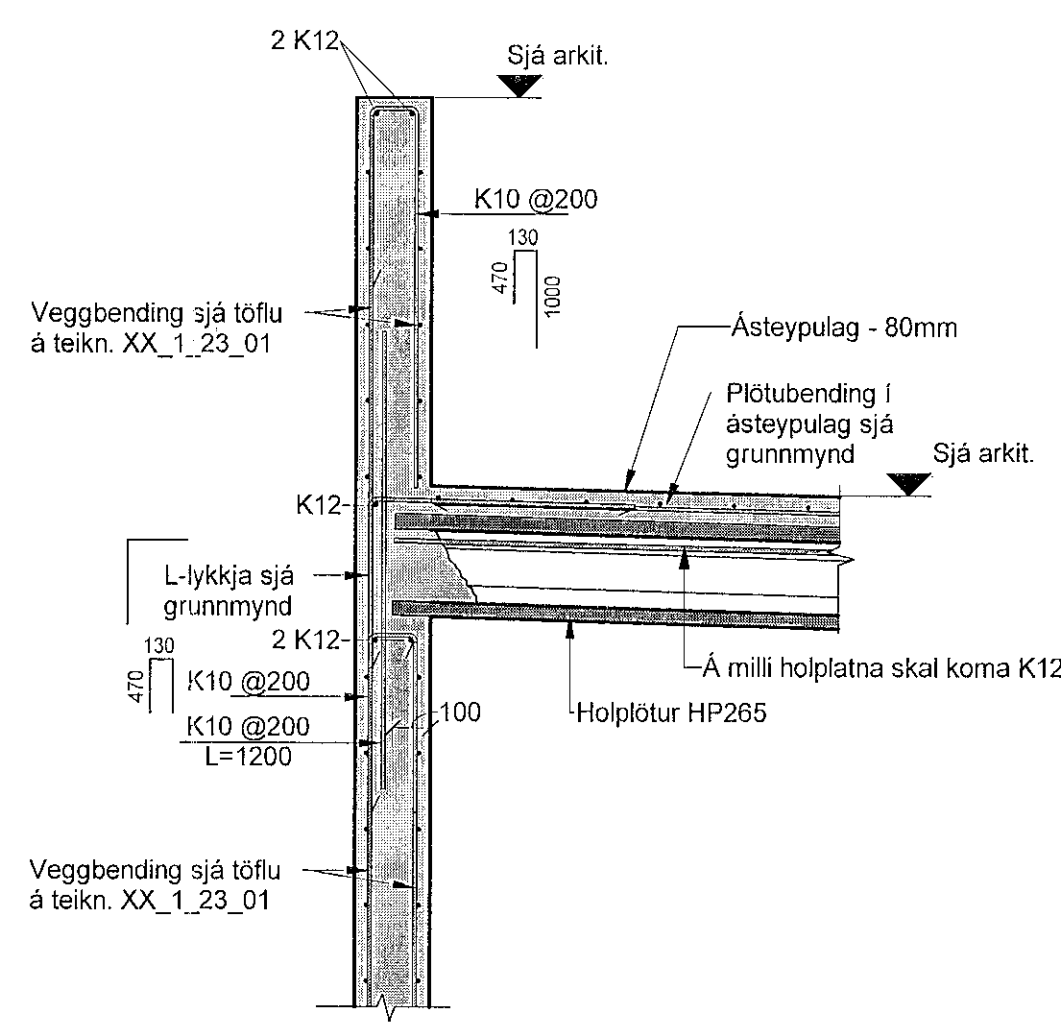

EH Snið EH
01.121.01 1 : 20

Skýringar

Öll mál eru í mm, nema hæðarkótar í m.
Þar sem op eru ofan við undirstöður beygjast standandi járn, sem hefðu gengið upp í vegg, inn í botnplötu.
Sjá almenn skýringablöð, XX_1_04_01, XX_1_04_02, XX_1_04_03, XX_1_04_04 og XX_1_04_05.
Sjá einnig gataplön og teikningar annarra hönnuða sem tilheyra þessu verki.
Verktaki skal hafa samband við hönnuð ef eitthvað er óljóst.

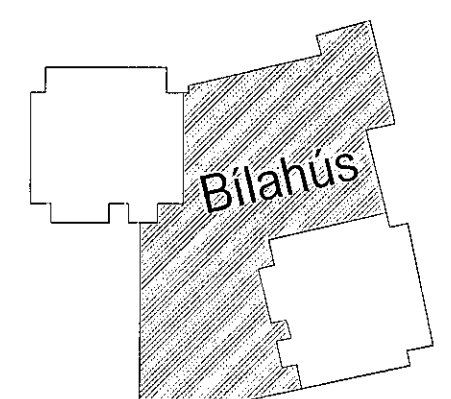

Hringhamar 31-33 - Bílahús
221 Hafnarfirði
Mhl.03
Burðarvirki
Járnþending
Snið og deili

TEKNIÐNÖMUR	BLASTVÆRÐ	HANNVÆRÐ	ISÓ
100488	A1	TEKNIAB:	MG
XX_1_23_22	YFRIFARIB:	BJP	
DAGS	MÆLIKVÆRÐ	ÓTGÁFA	
07.02.2023	1 : 20	A	

Útgáfuúmer og sagsseting aðalskipdata: A 31.08.2022
Hönnuður: Bjarni Jón Pálsson - kt. 291163-5139
Hönnunarsjött: Hallur Kristmundsson - kt. 220573-3899