

Sambýkt þann
16. maí 2023
fr. byggingarfulltrúna í Hafnarfirði
Róbert A. Róbertsson

- TEKNIKALEIÐBEIÐNINGAR: 210114-SA-141 TIL 146
- VÍÐAD TIL TEIÐINGAR NR.: 210114-SA-101 FYRIR ALMENNAR UPPLÝSINGAR
 - VÍÐAD Í SKIÁL NR.: 210114-ESP-01 (STAUFORSKRIF) UM BURÐARDL, SKOÐUN OG ALMENNAR UPPLÝSINGAR
 - VÍÐAD Í SKIÁL NR.: 210114-01-01 TEIÐINGASKIÁL
 - VÍÐAD TIL BYGGINGATEKNIKA NÚMÉR: 210114-SA-106 Aft 20 FYRIR STAÐSETNINGAR
 - UNO ALLAR BOLTADAR TEIÐINGAR ERU SVIÐER/BURÐAR TEIÐINGAR, (FLOKKUR A EN 1993-1-8 (3-4)), MEÐ FRÁVINGUM 3 mm
 - BOLTADAR TEIÐINGAR MEYRAR MEÐ „CLASS 10.9“ ERU FORHÆTTAR BOLASAMSETNINGAR (FLOKKUR B,C EDA E TIL EN 1993-1-8 (3-4)). SÁRNU ALMENNAR TILGÆTUSAMMÖR TEIÐINGAR UM FORHÆTTUADAFERD.
 - EF EKKI ANNAÐ SÝNT EGA SUDUR AD VERA AMÁL 6mm ALLTAF.
 - ZAMZD SMITTELNAR MEÐ BRÖD OG BR SKINNUM GAÐI 8 EGA AD VERA, HEIT EFTIR AD KRANAKORIN FUR VERD STILLT SAMRÝMÉNT TEIÐINGU NR. 210114-ESP-01 (STAUFORSKRIF).
 - NEIÐAD ANNAÐ SE TEIÐ FRAM.
 - ALLAIR HÉÐAFLUKTAR ERU Í [mm] VÉR TIL M.S.L.
 - ÖLL MÁL ERU [mm].

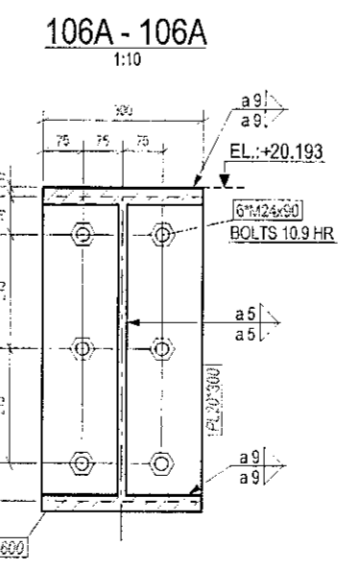
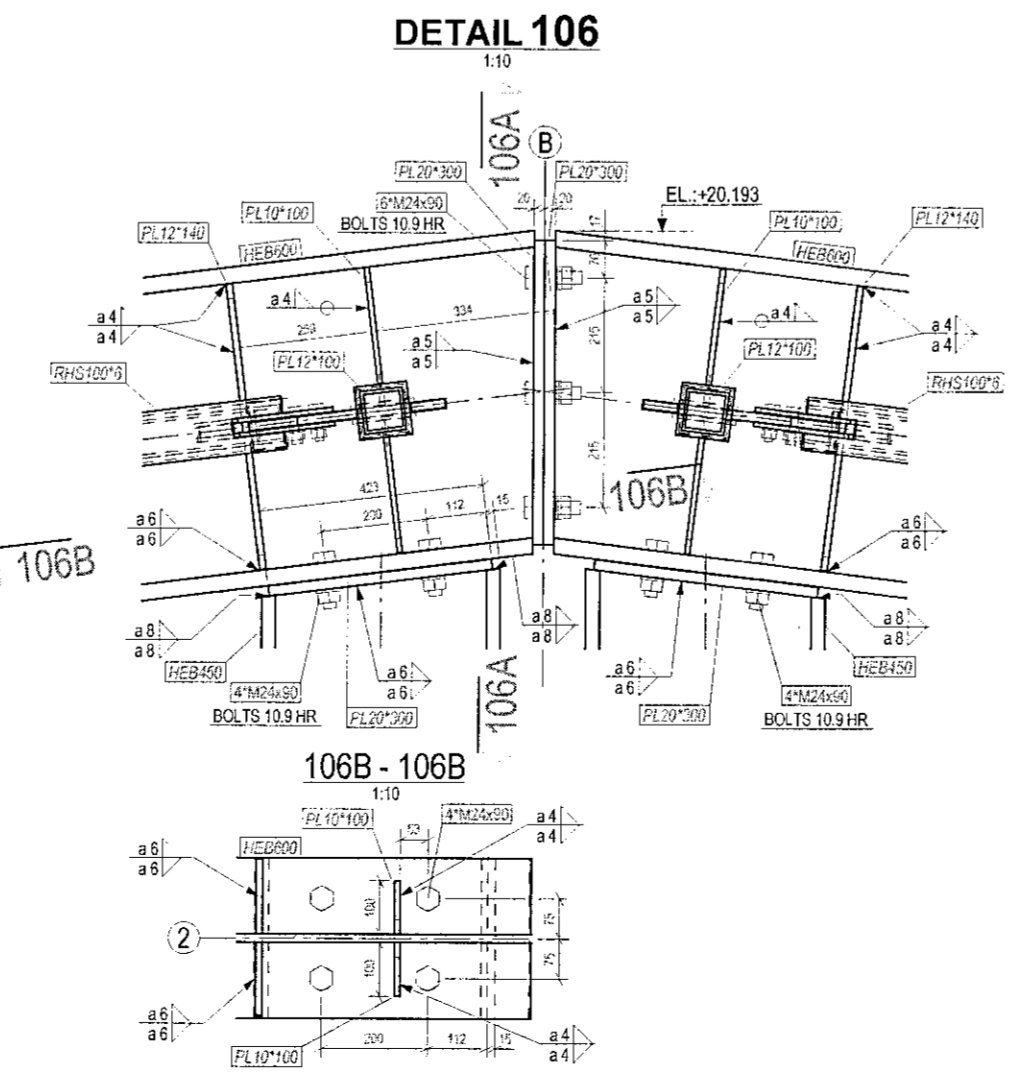
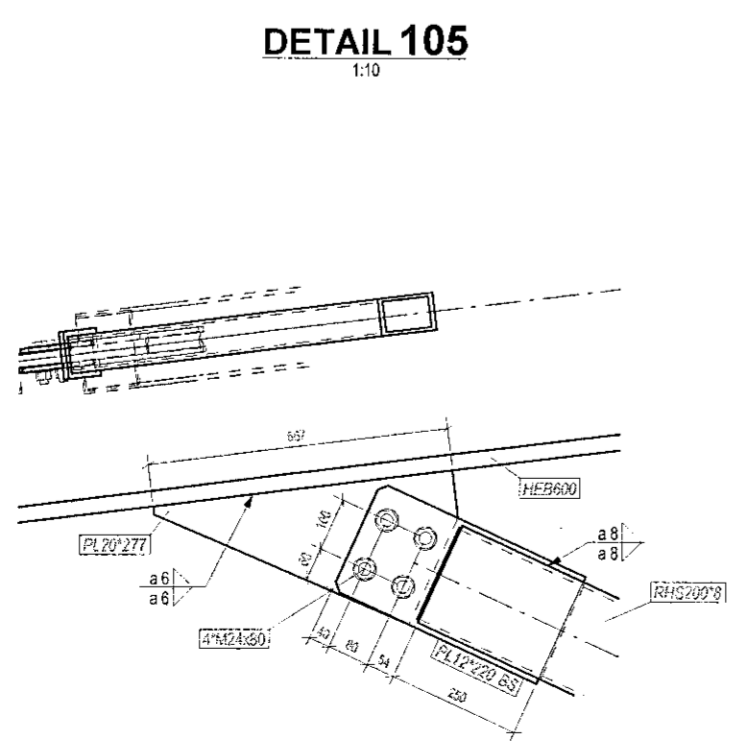
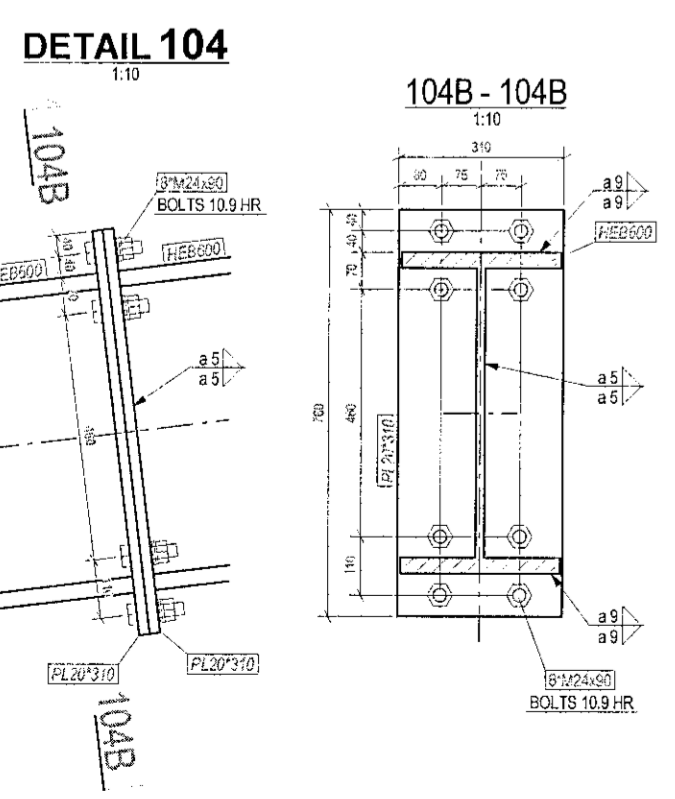
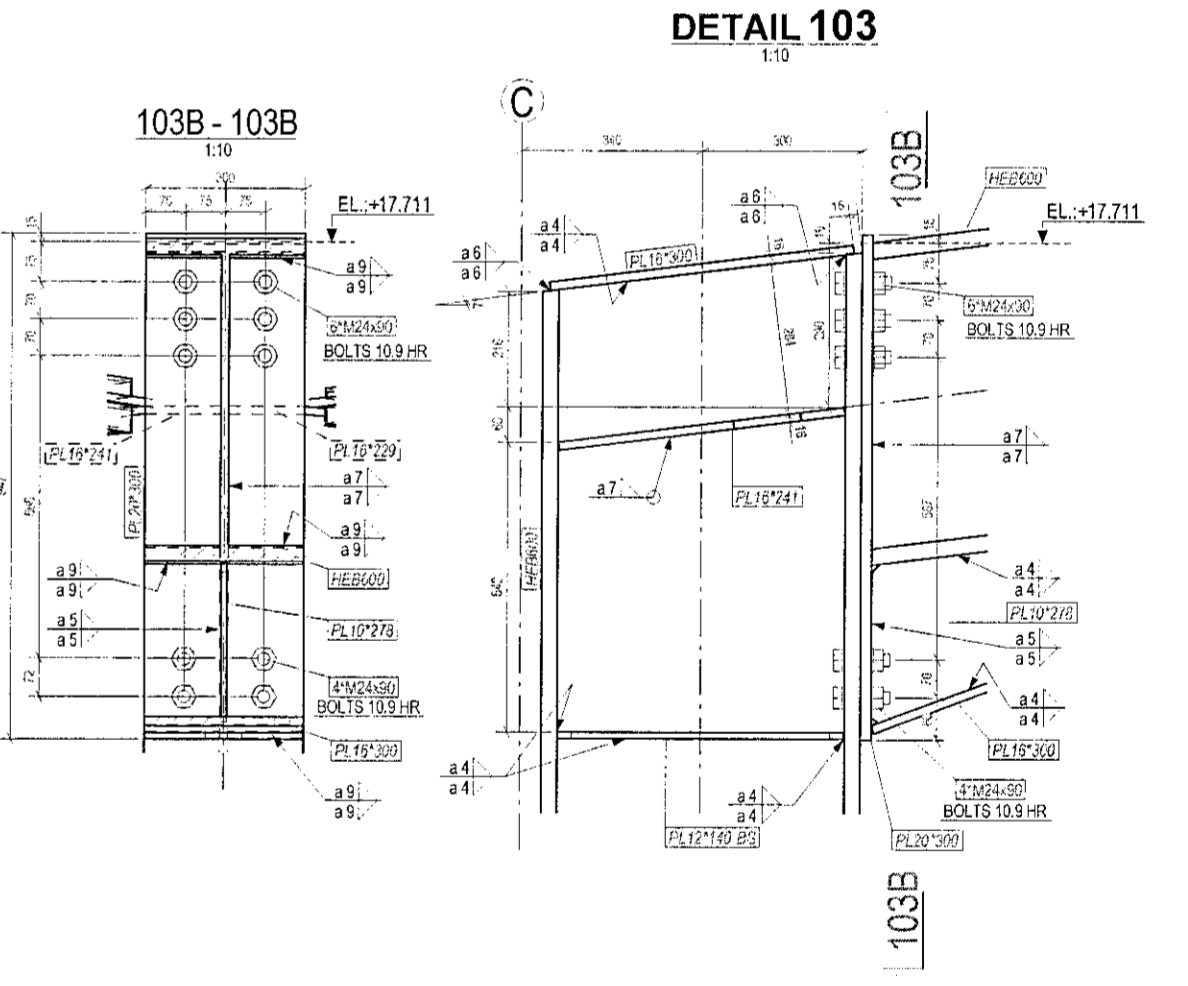
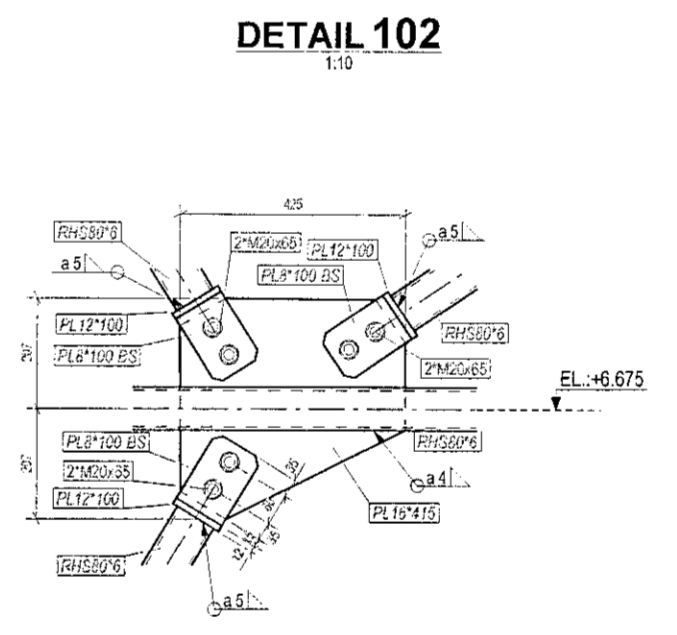
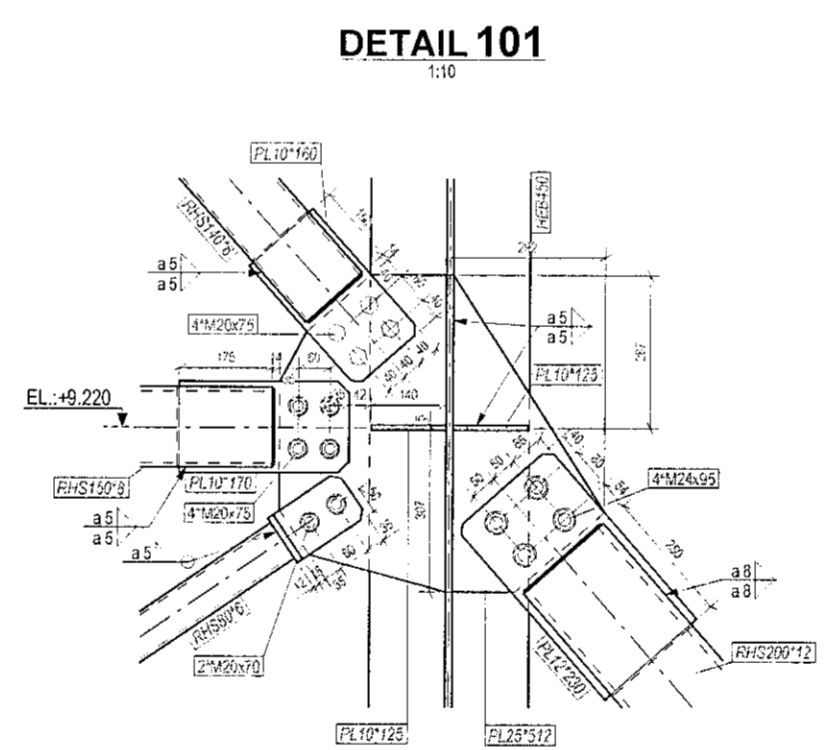
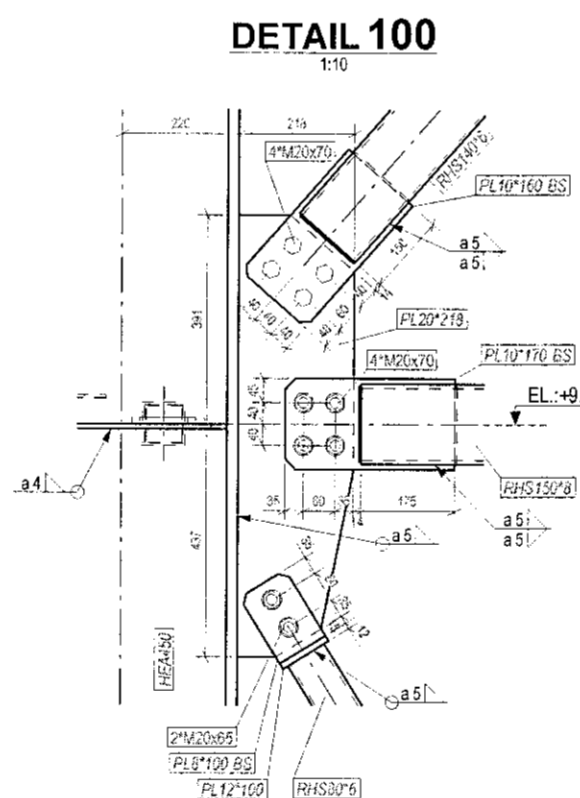
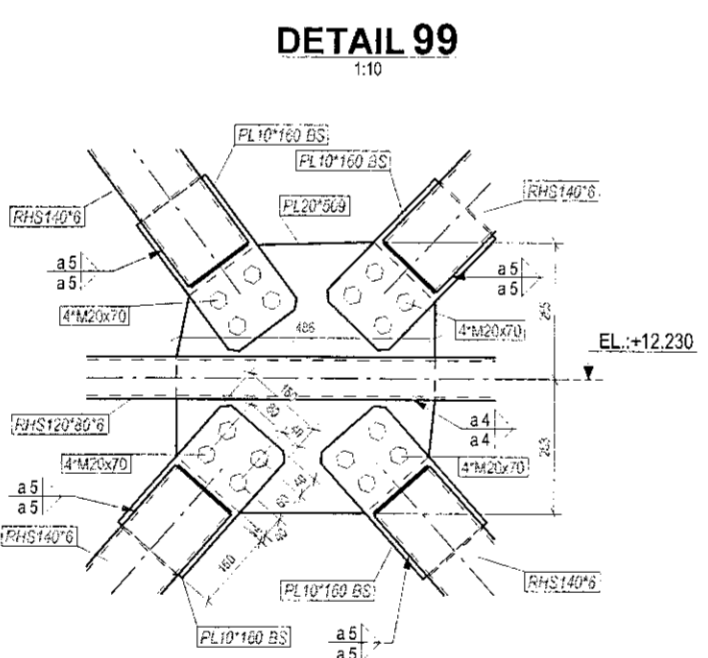
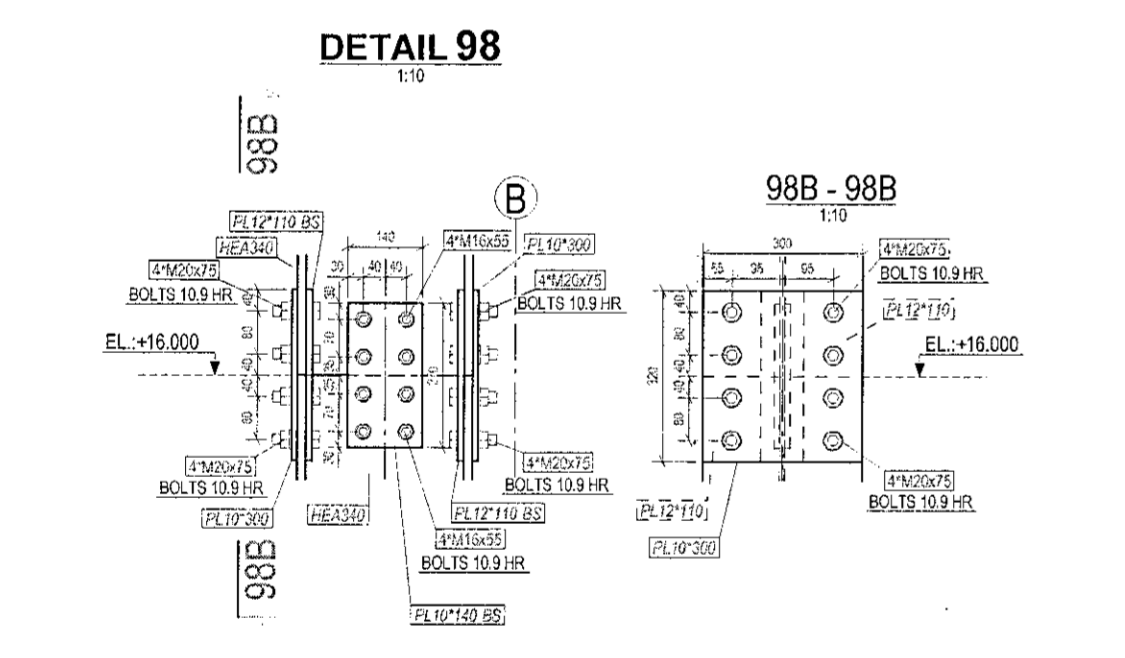
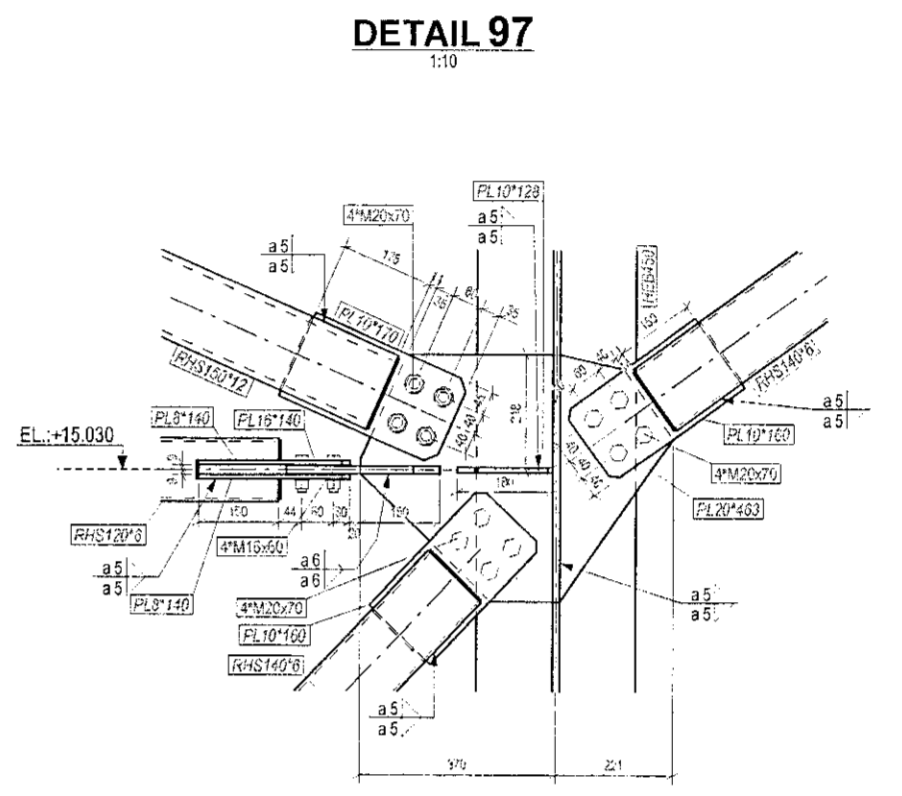
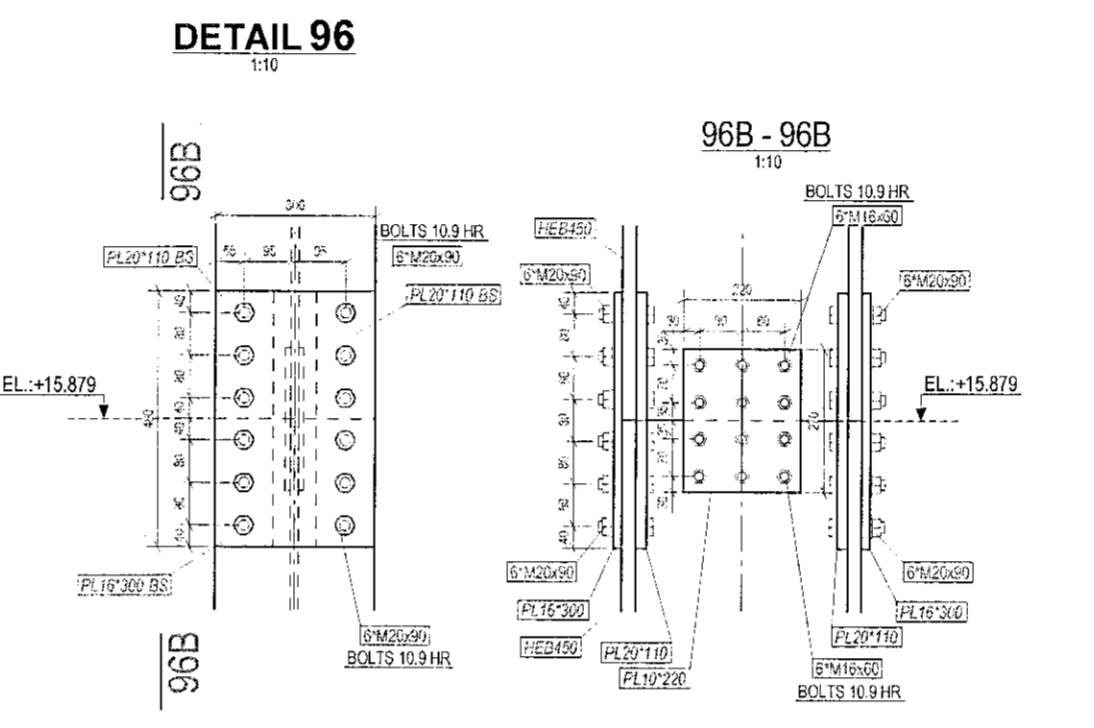
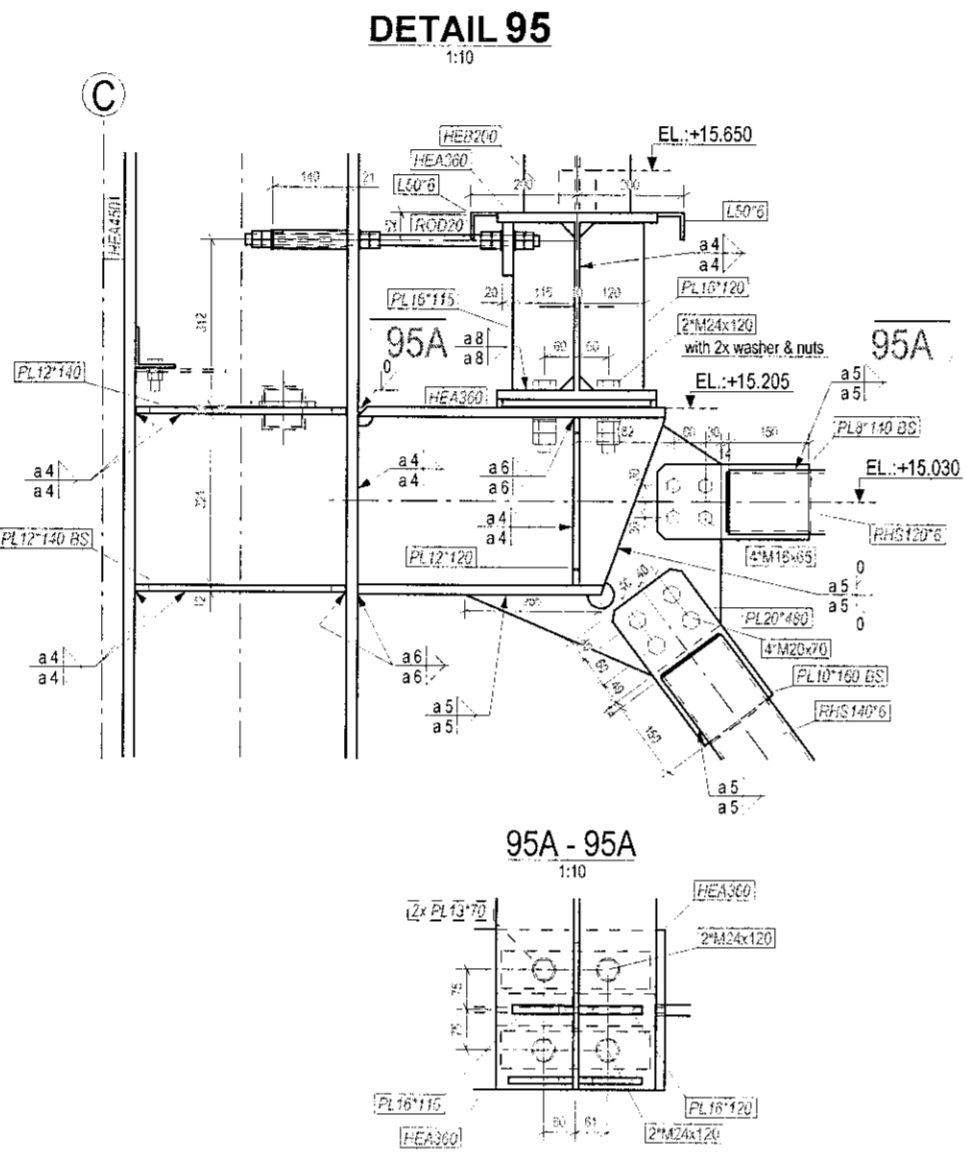
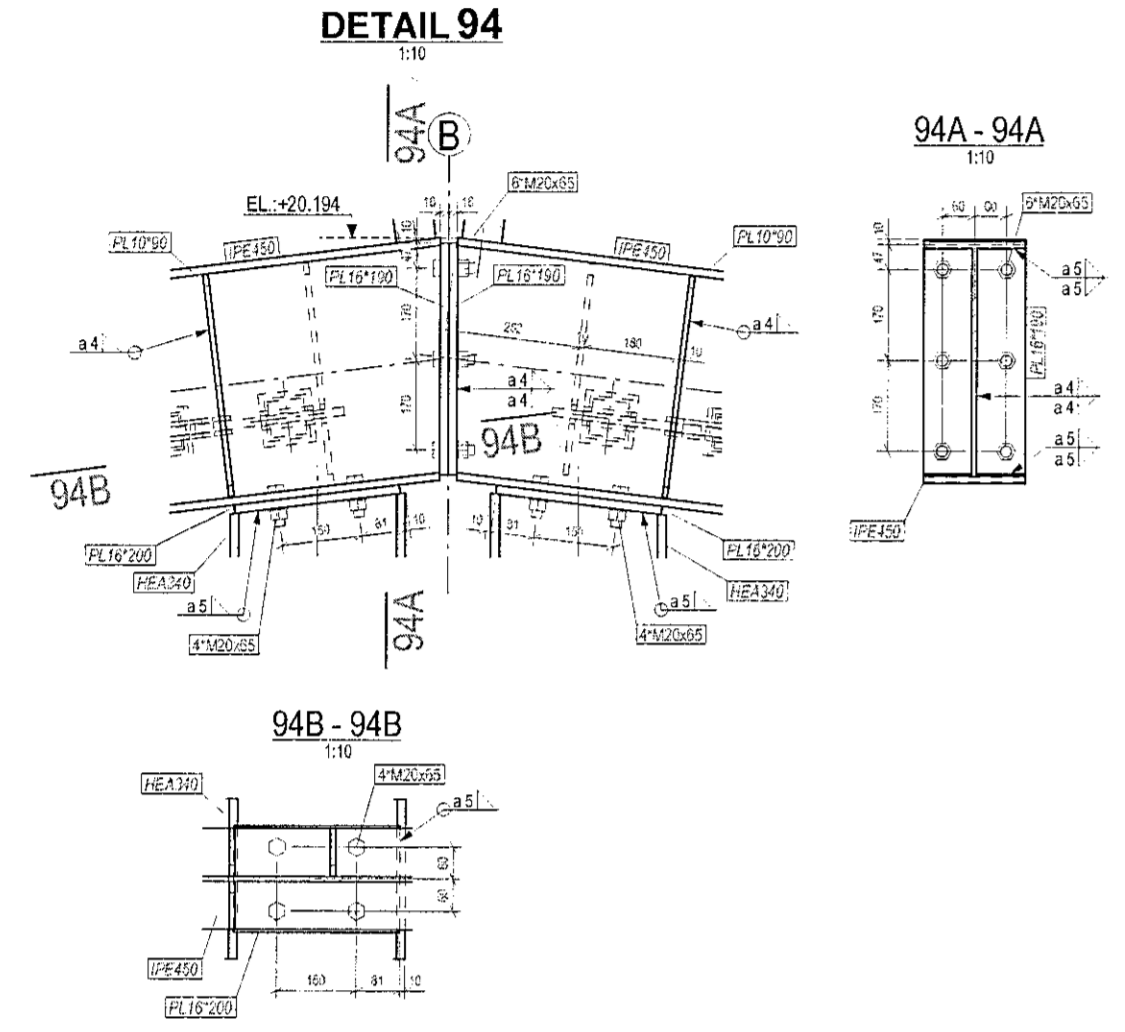
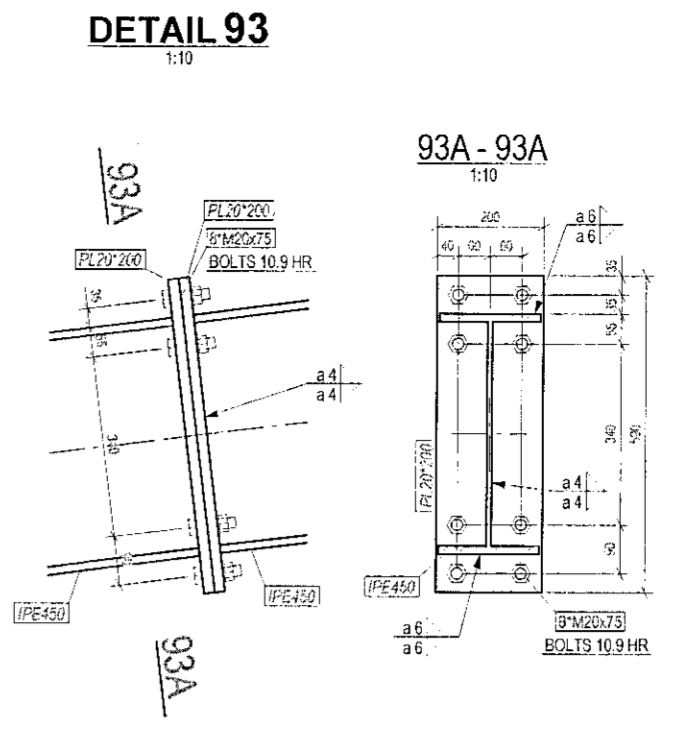
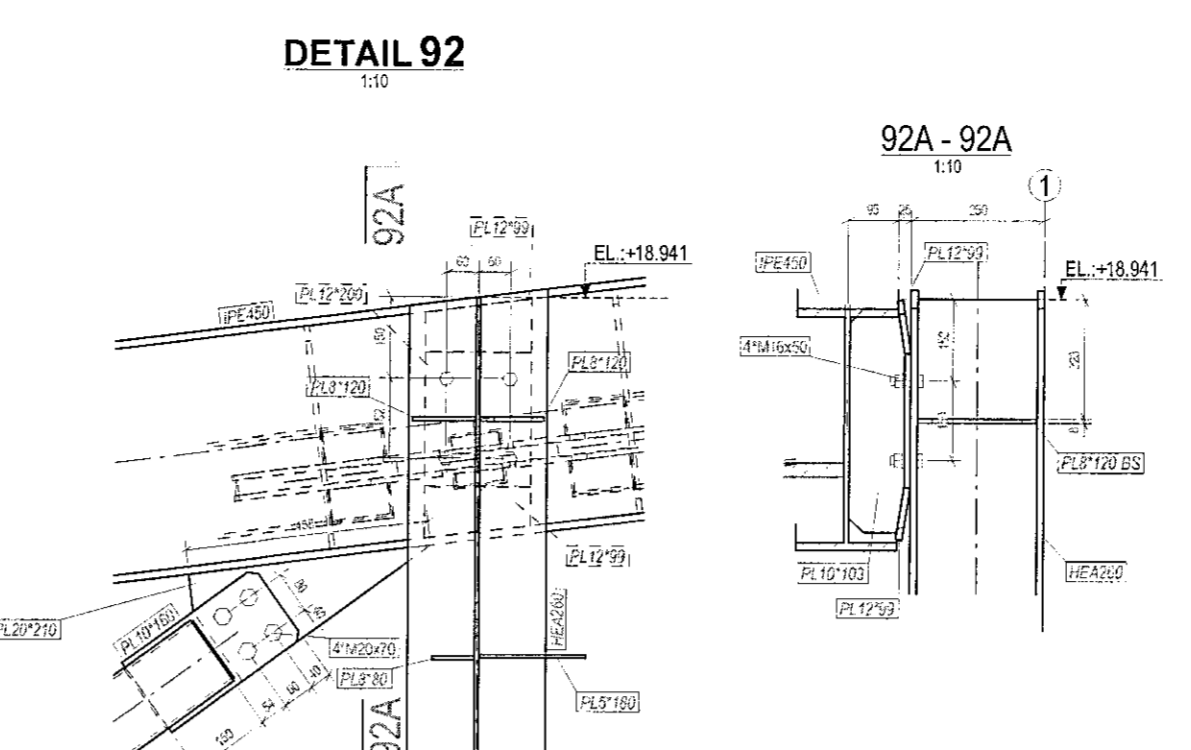
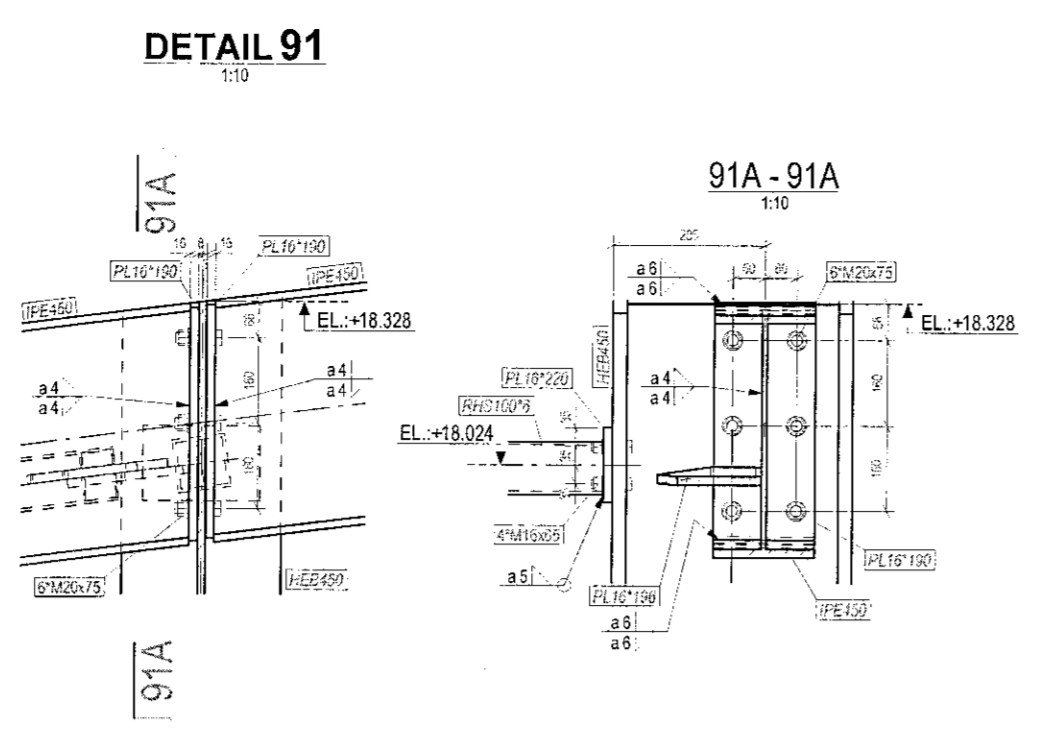
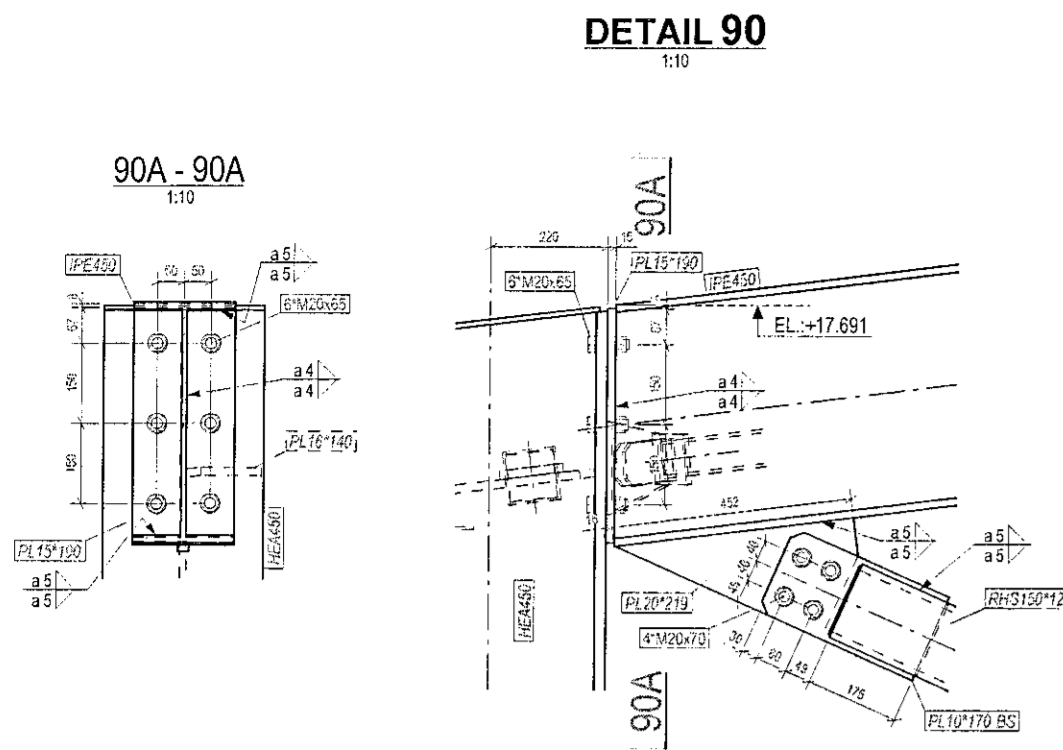

FYRIRTEKI		TEKNAÐ		VEIÐKPTAVINARTEKNIKNÚMÉR	
SOH		4D DESIGN AS		NAFN TEIÐINGAR	
221 Lönguveg 2, Ísland		1307 Nesska, Reykjavík		Öseyrarbraut 25	
VERKHETI		VERKNAÐUR		Details 90..106	
Öseyrarbraut 25 boat yard		210114		MELKUNARDEI	
01 12.01.2023		VINNU TEIÐING REISING		TEIÐINGUNUMÉR	
ÓTG.	DAGS.	SKYRING	RR	DD	SAO
			Teknað	Virðing	Sambýkt
Sigurbjartur Halldórsson, kt. 230656-3479			Róbert A. Róbertsson		
Byggingateknifrádráðgjafi, Laugavegur 5, 110 Reykjavík			13. maí 2023		
Sími: 7752233, Netfang: sigurb@stremur.is			MELKUNARDEI		
			1:10		210114-SA-145
					ÓTGAFI
					01