

Vestn. 13.4.2022 15:59:40 Öprettun: 19.04.2022

Útg.	Dags.	Skýring	Br. af: Yfirf.
A	19.04.22	Verktækningar	ÖG BJP

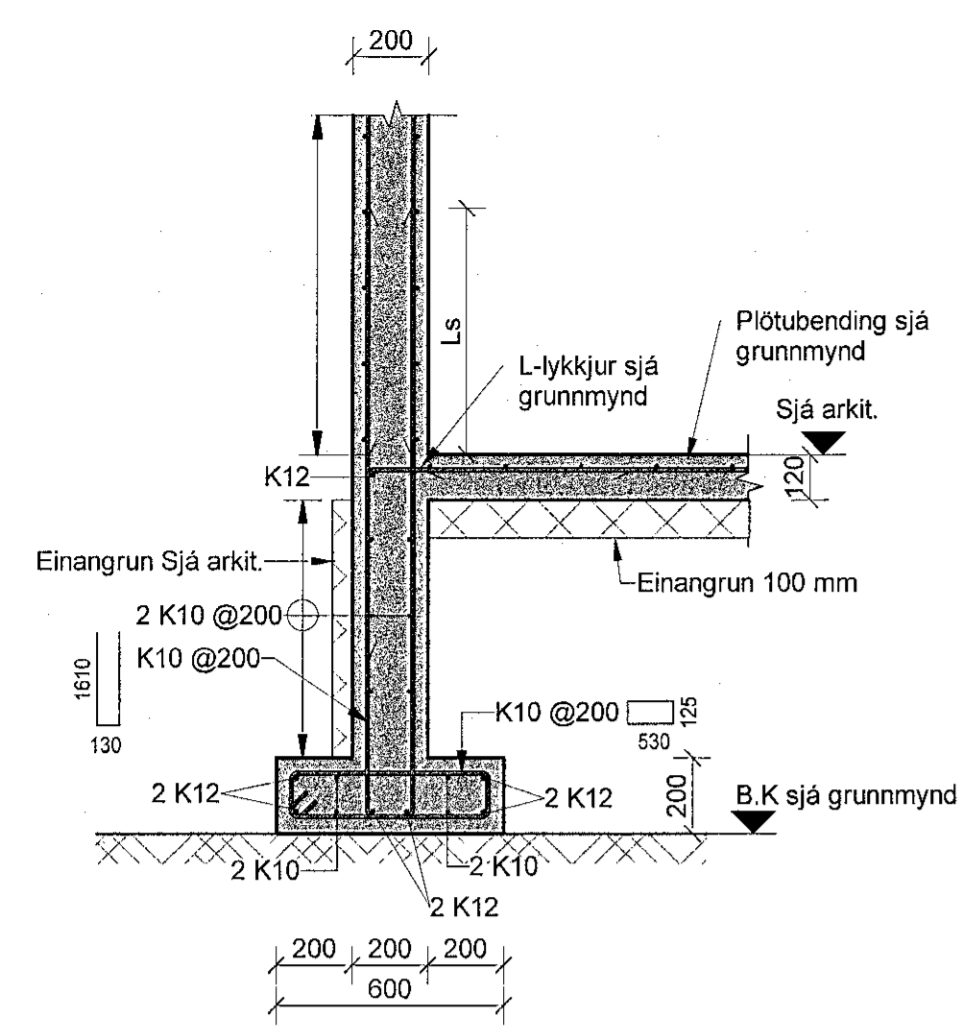

BA Snið BA
-1,1,21,01 1 : 20

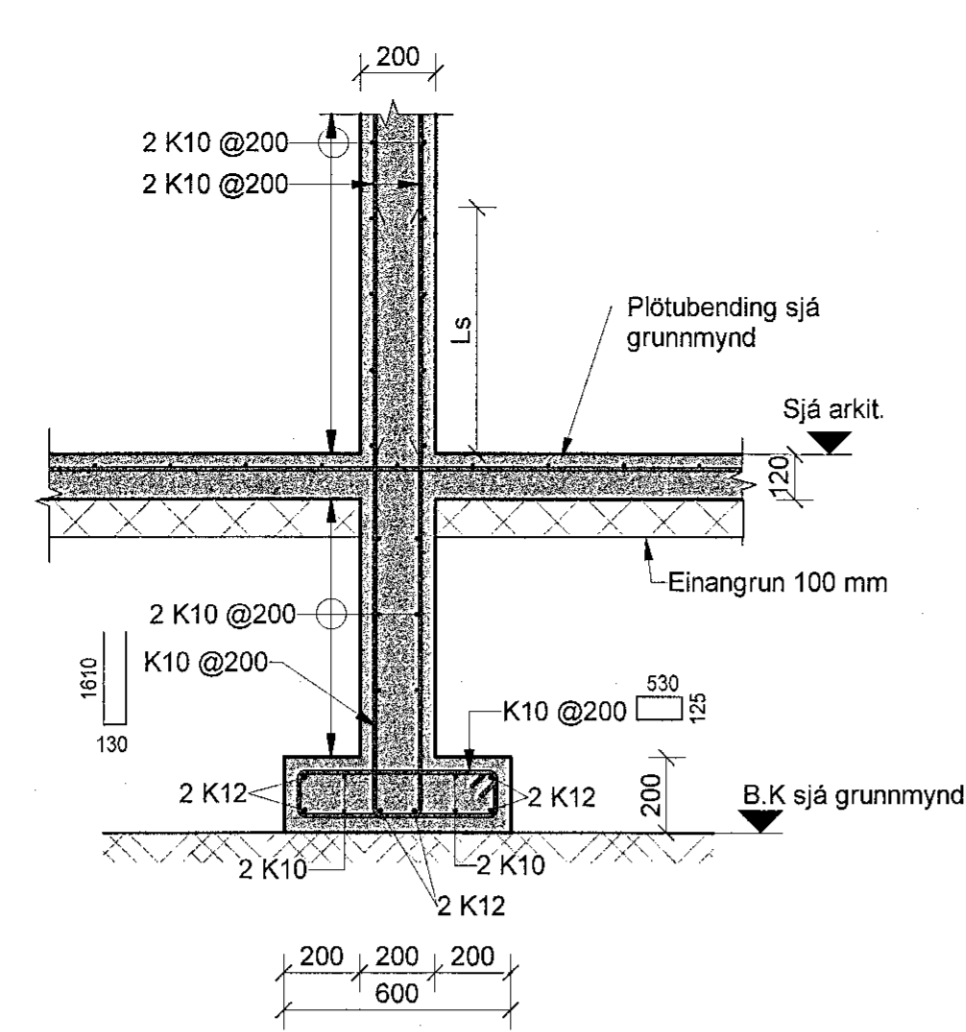

BB Snið BB
-1,1,21,01 1 : 20

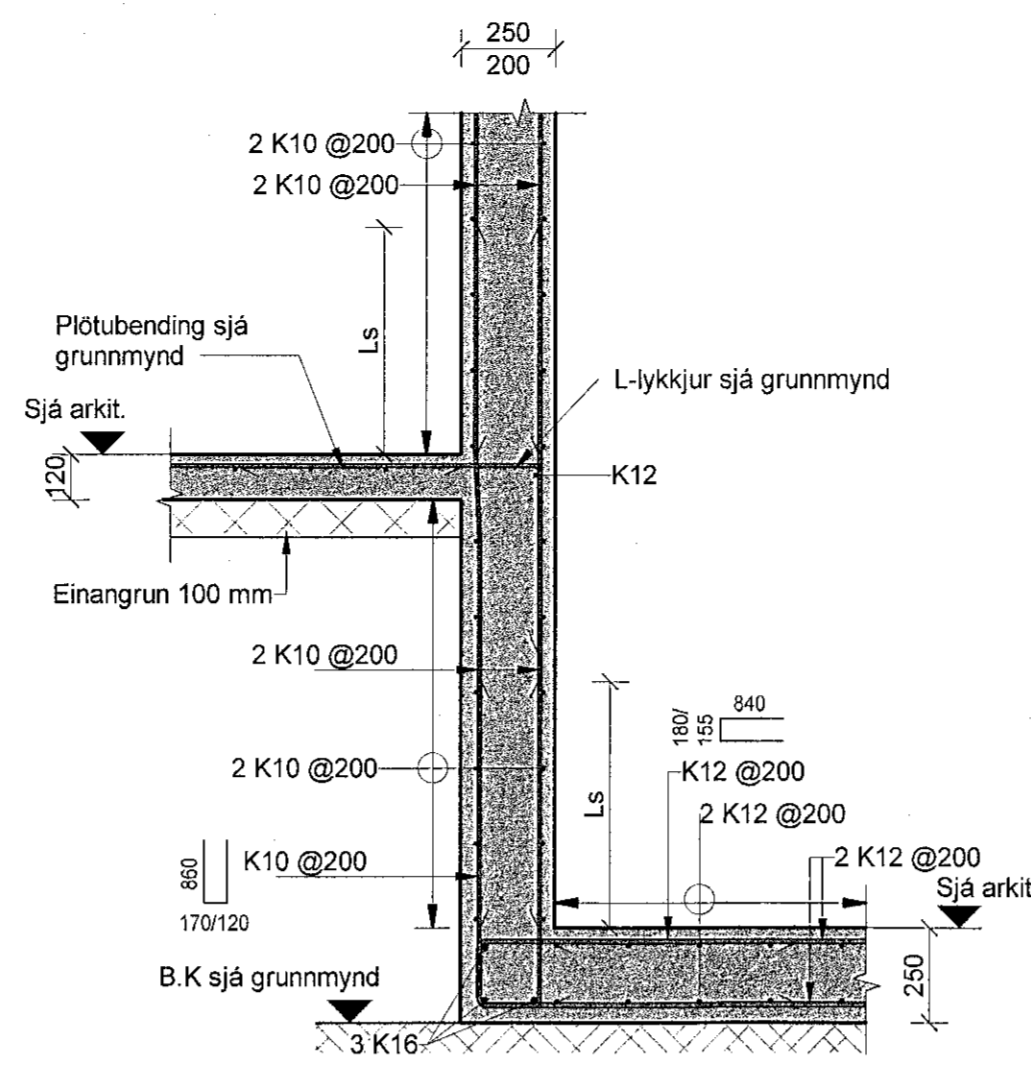

BC Snið BC
-1,1,21,01 1 : 20

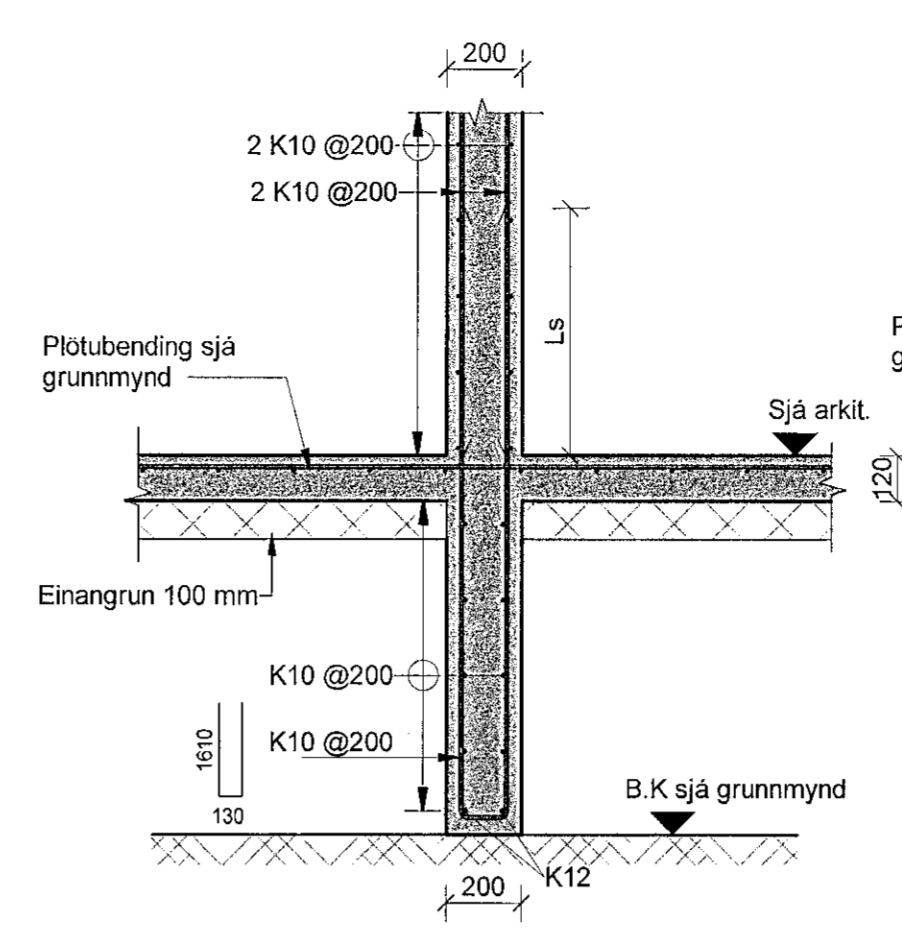

BD Snið BD
-1,1,21,01 1 : 20

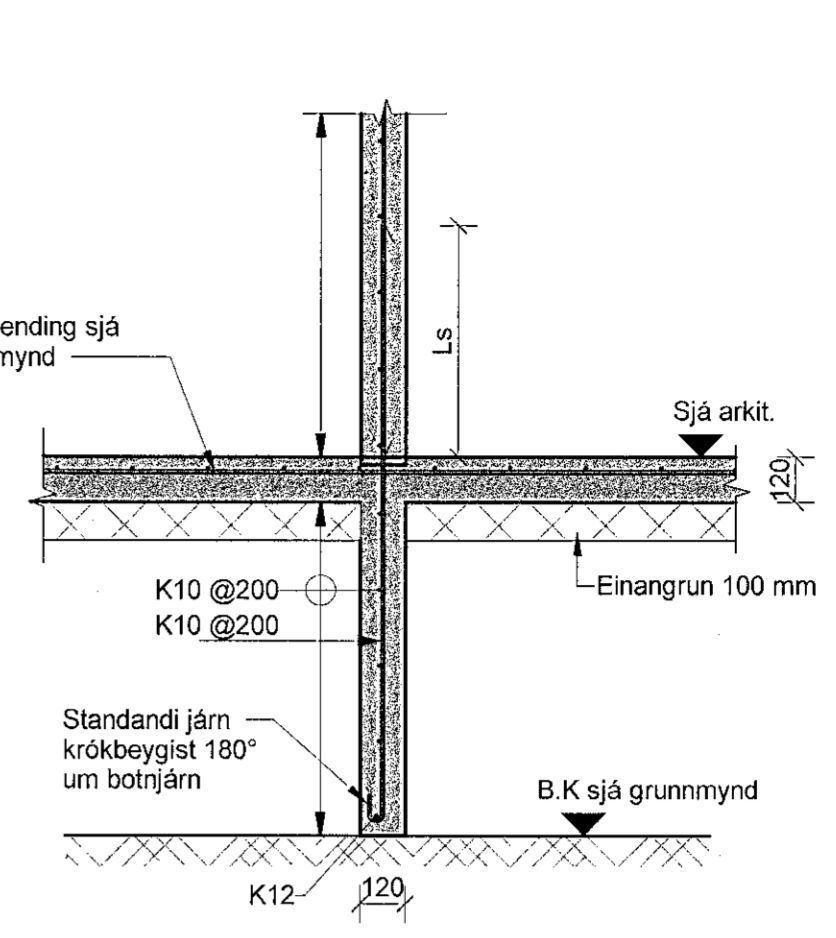

BE Snið BE
-1,1,21,01 1 : 20

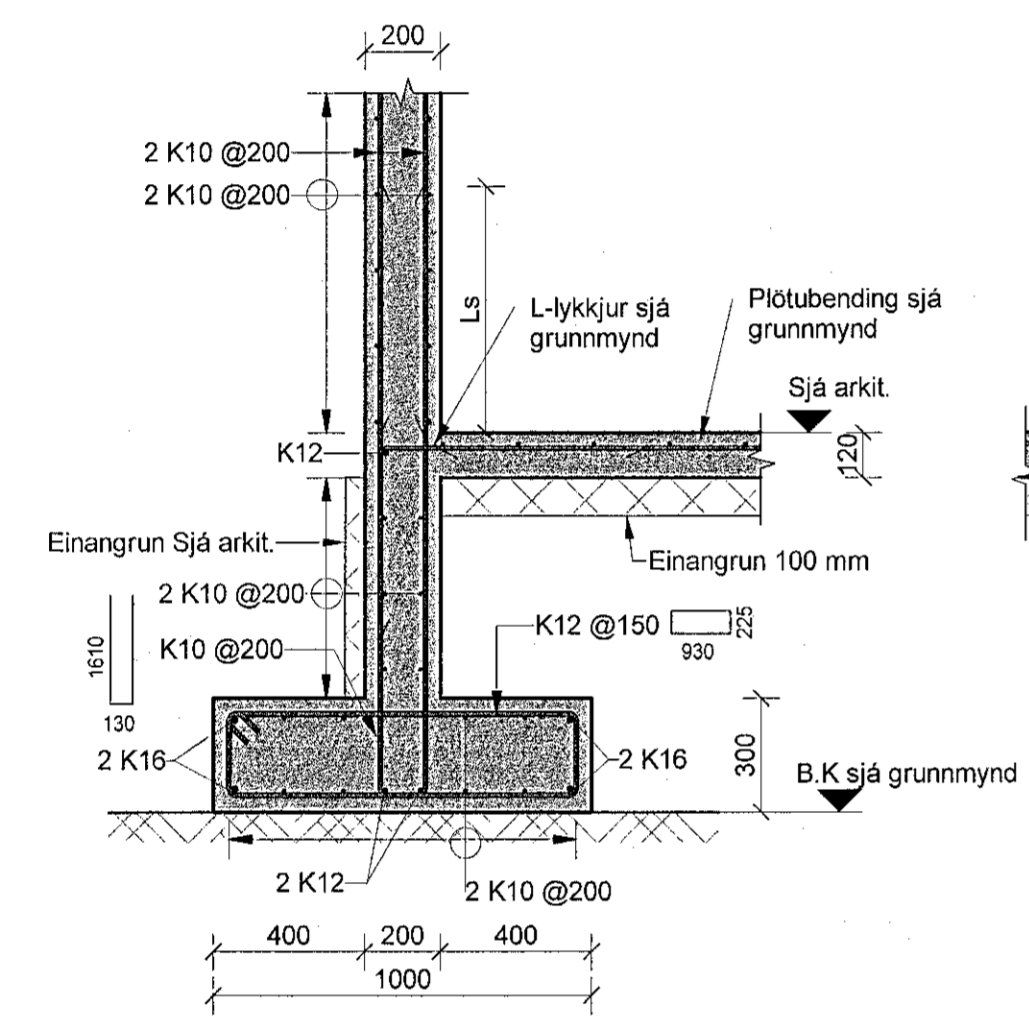

BF Snið BF
-1,1,21,01 1 : 20

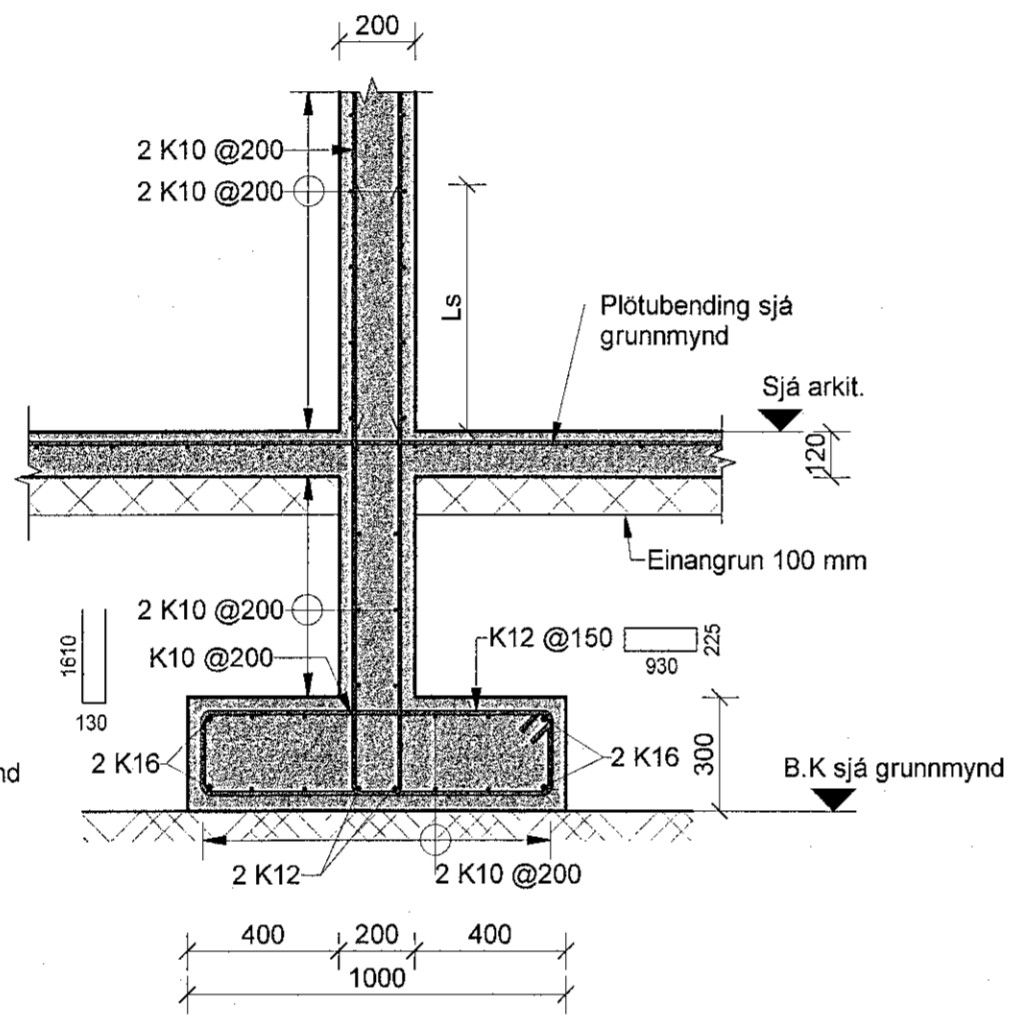

BG Snið BG
-1,1,21,01 1 : 20

Skýringar
Öll mál eru í mm, nema hæðarkótar í m.
Par sem op eru ofan við undirstöður beygjast standandi járn, sem hefðu gengið upp í vegg, inn í botnplötu.
Sjá almenn skýringablað, XX_1_04_01, XX_1_04_02, XX_1_04_03, XX_1_04_04 og XX_1_04_05.
Sjá einnig gataplön og teikningar annarra hönnuða sem tilheyra þessu verki.
Verktaki skal hafa samband við hönnuð ef eitthvað er óljóst.

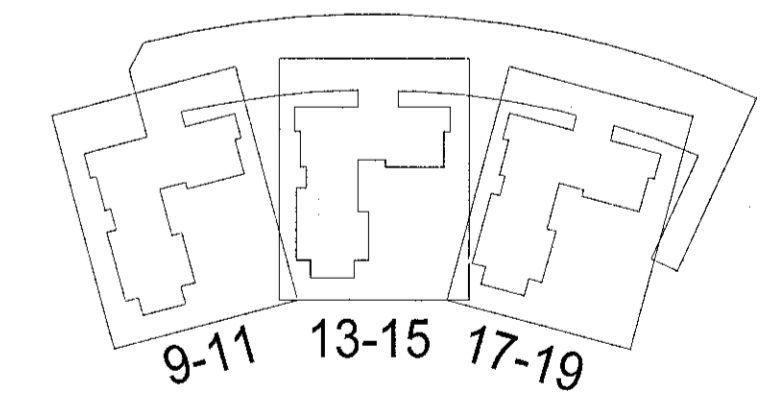

Hringhamar 9-19
221 Hafnarfirði

Burðarvirki - Hringhamar 9-19
Járnbanding
Snið og deili

TEKNIÐNÖMUR	BLAÐST/ERD	HANNAÐ	ÖÖ
9354-001	A1	TEKNAÐ	MG
XX_1_23_11		YFRFARAR	BJP
DAGS	MELKIVARÐI	UTGÁFA	
19.04.2022	1 : 20		A

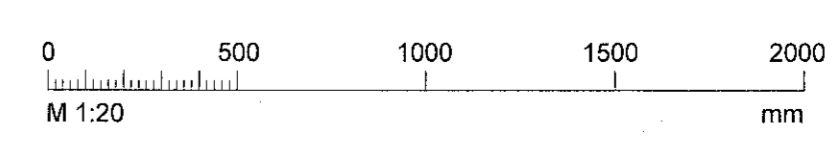

Útgáfunúmer og dagsetning aðaluppskriftar: Frumútgáfa 12.03.2022
Hönnuður: Ólafur Ósvalbjörnsson kt.310380-3509
Hönnunarsjón: Haraldur Ingvarsson kt. 030966-3389