

Samykkt þann
11 SEP 2017
Byggingarfræðistofa
F.H. Steinar Stenar Jónsson

Skýringar
17. SEP 2017
Höfnir H. Hórn

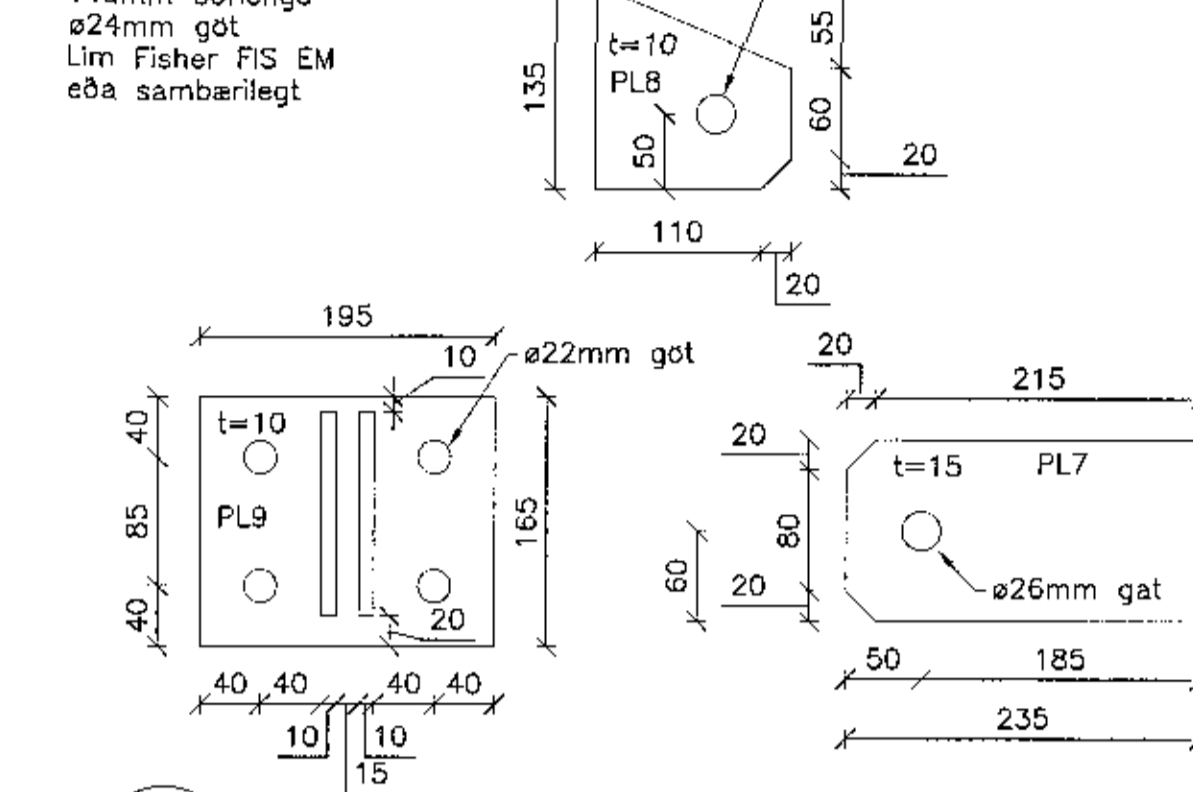
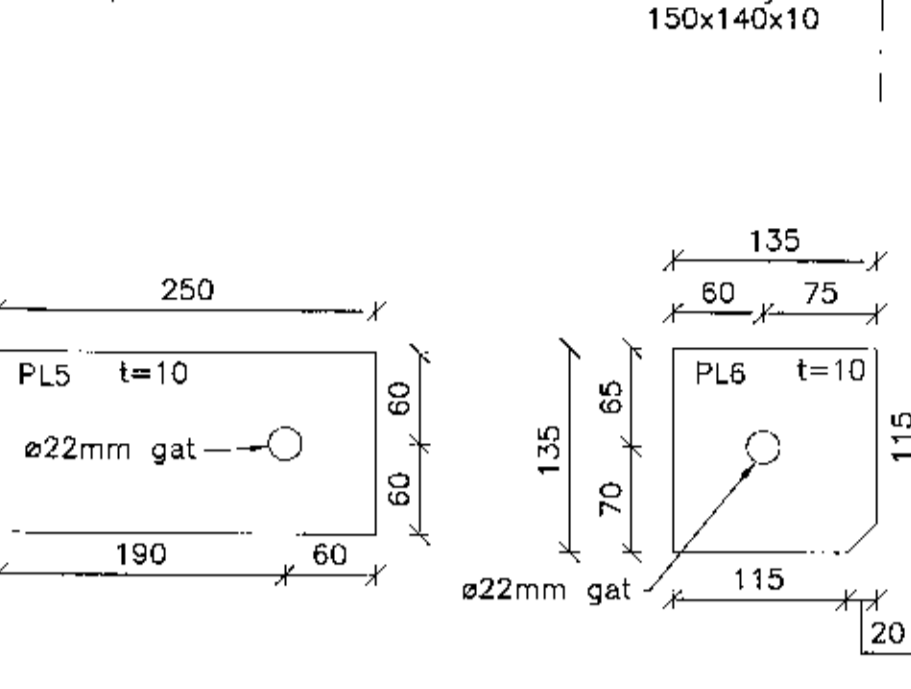
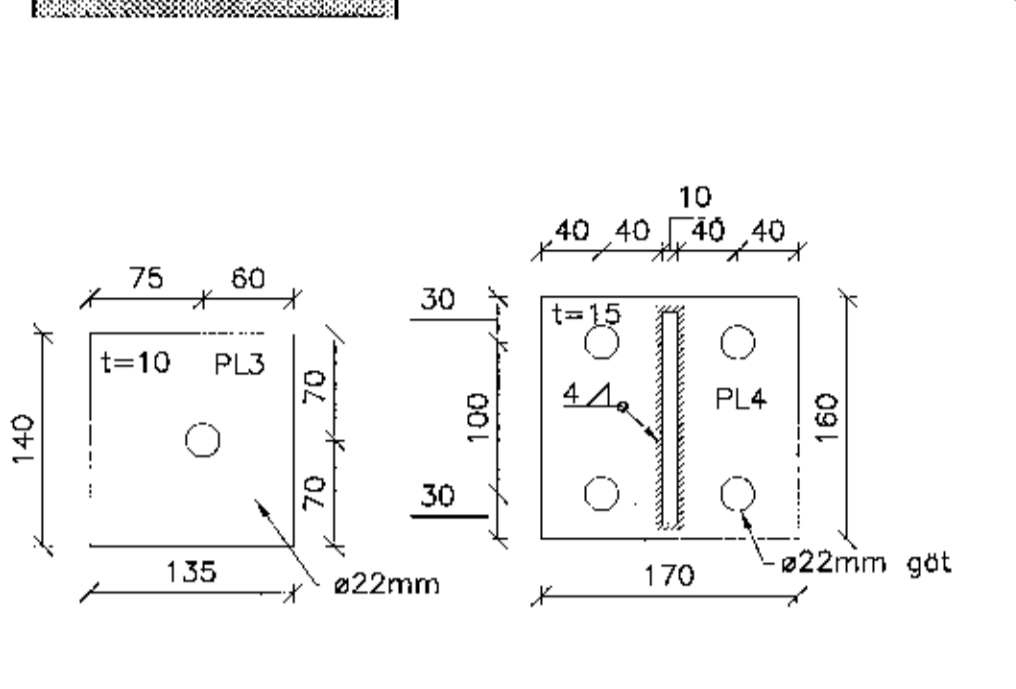
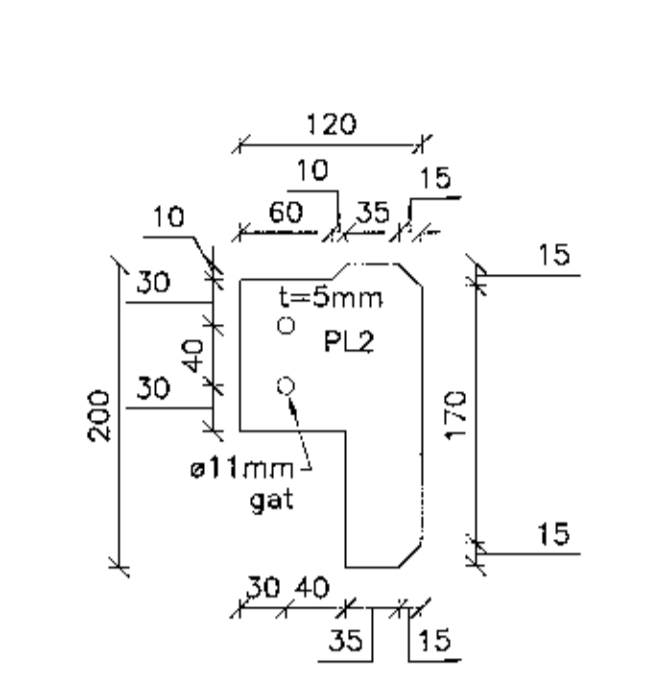
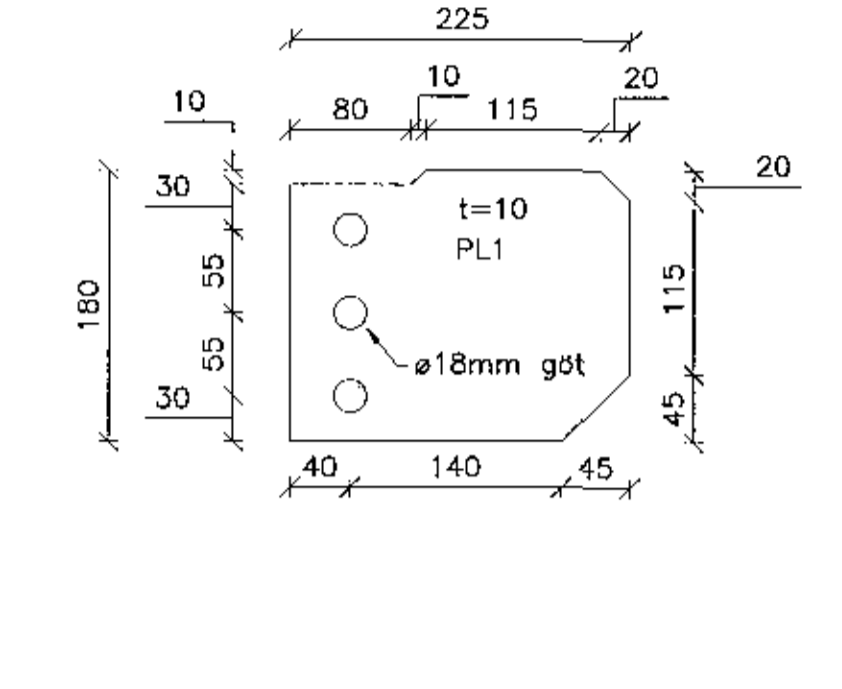
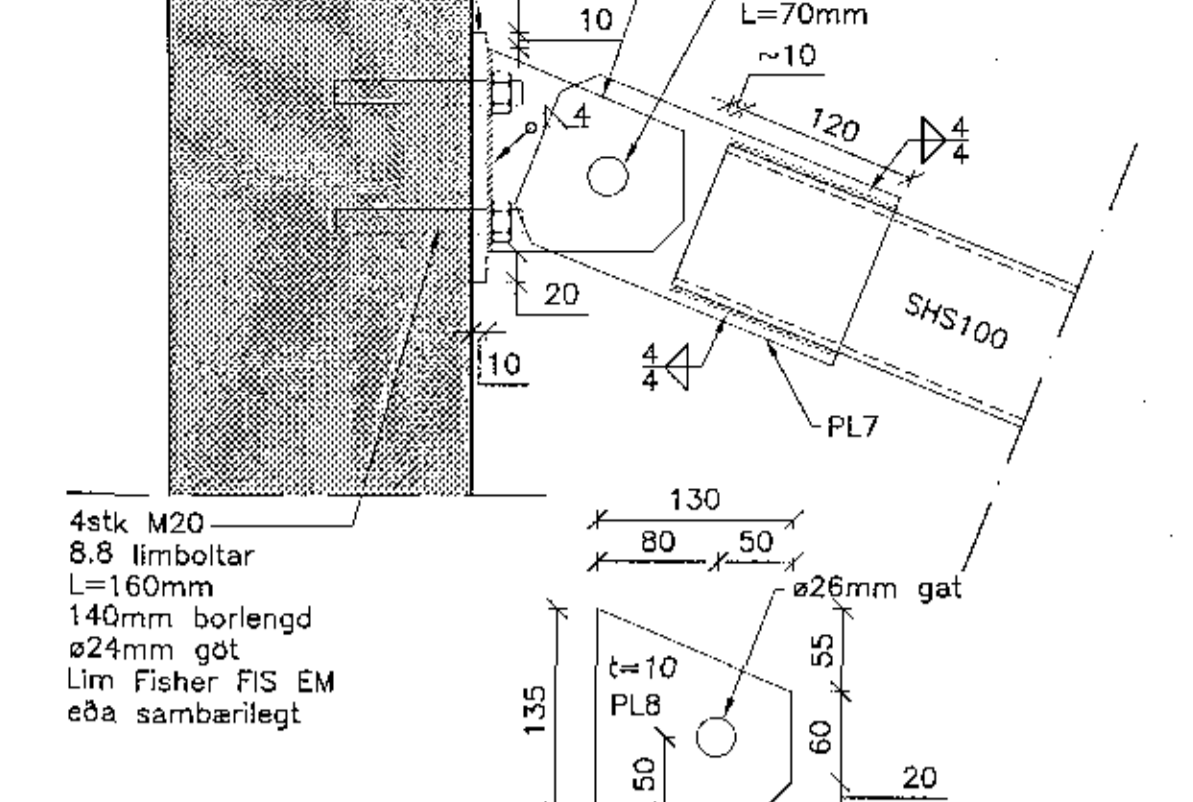
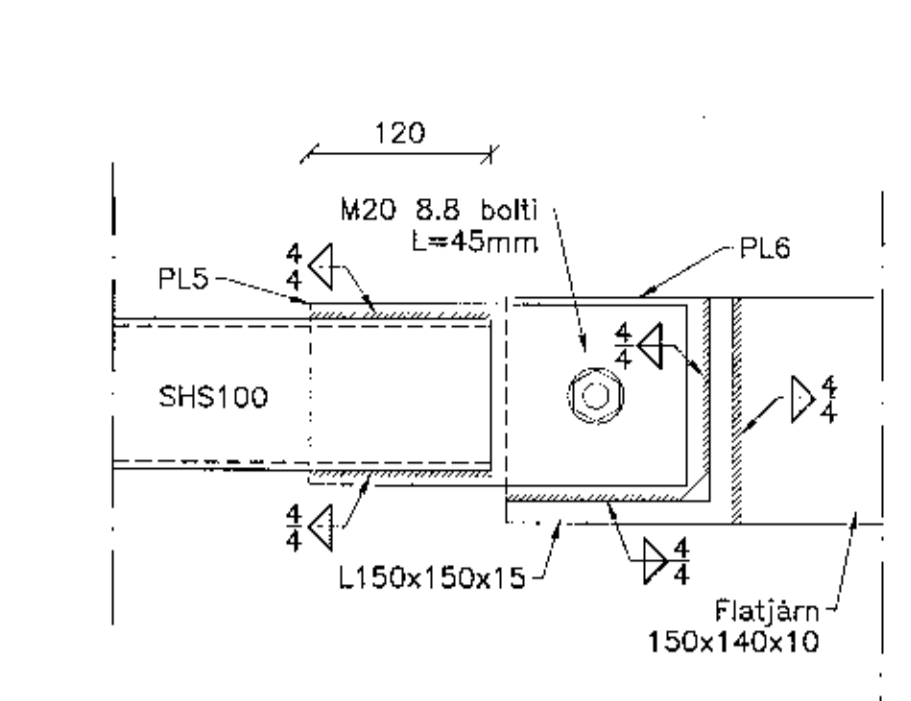
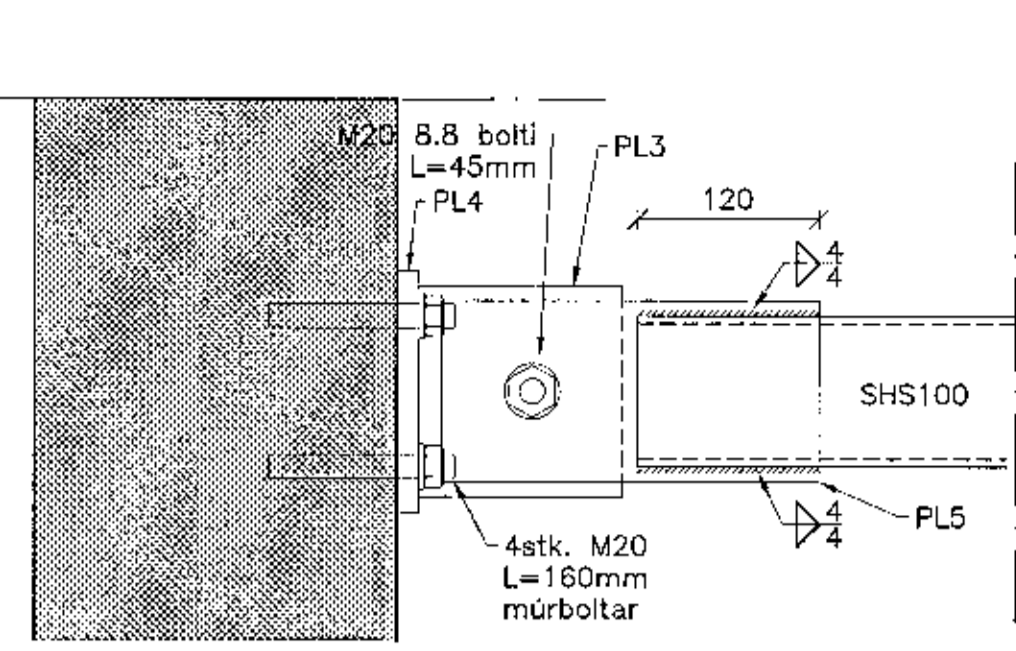
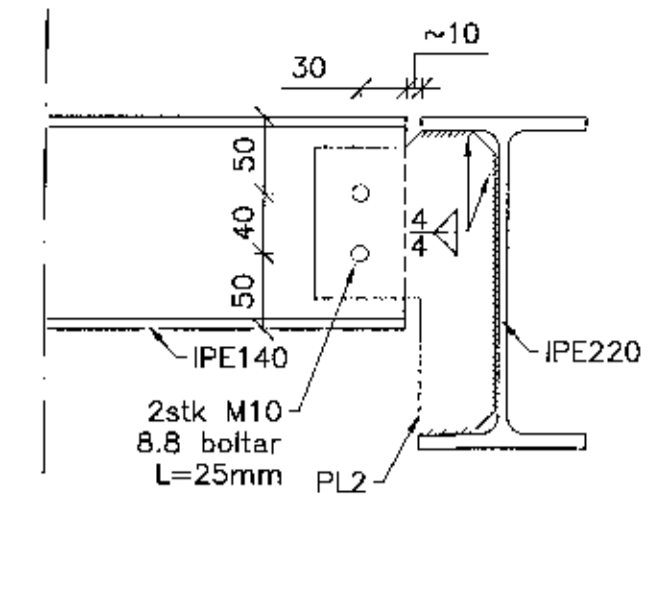
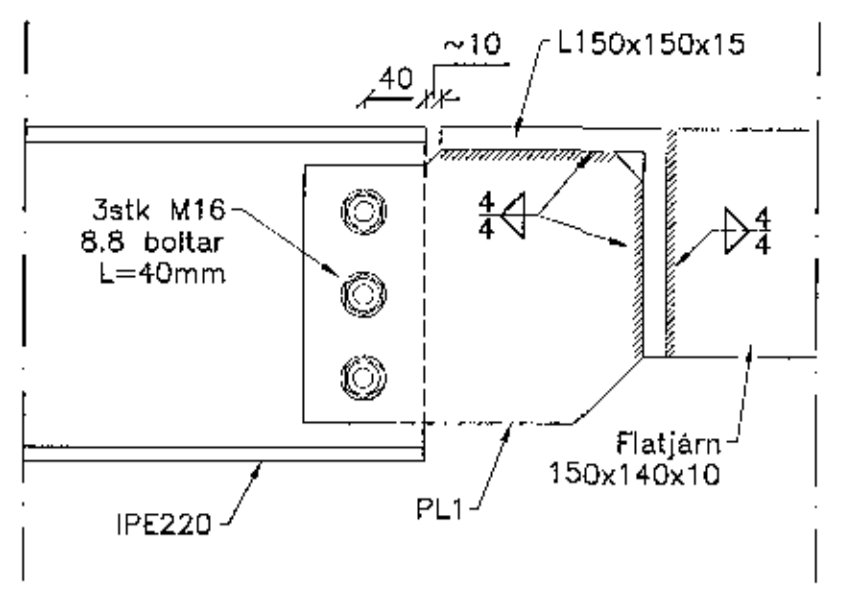

50 Tenging IPE langbita við stálgrind
B(25)01 B(27)01 Mkv: 1:5

51 Tenging IPE140 bita við reykflúga
B(25)01 B(27)01 Mkv: 1:5

52 Tenging kassaprófilis við úttegg
B(25)01 B(27)01 Mkv: 1:5

53 Tenging kassaprófilis við stálgrind
B(25)01 B(27)01 Mkv: 1:5

54 Tenging hallandi kassaprófilis við úttegg
B(25)01 B(27)01 Mkv: 1:5

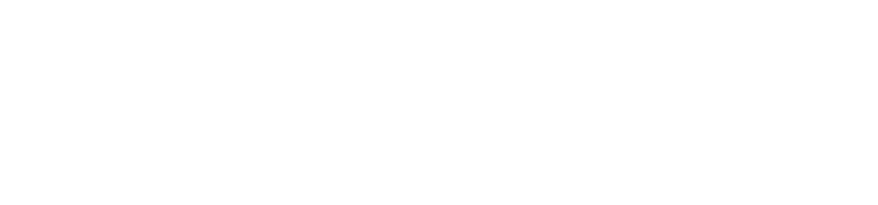
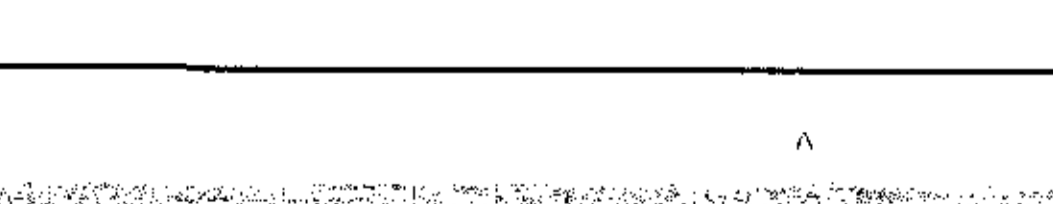
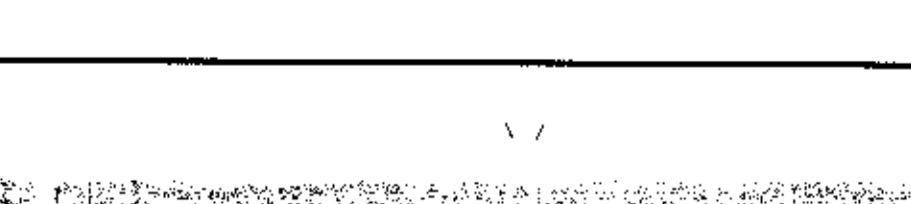
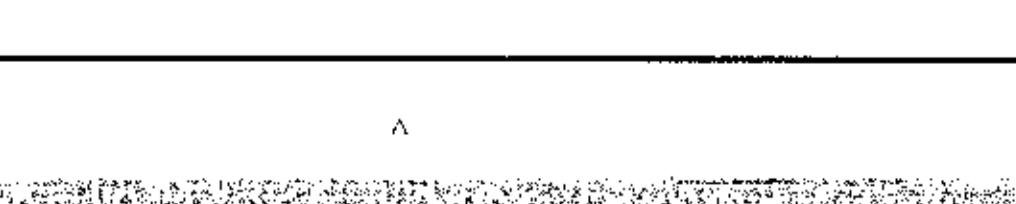
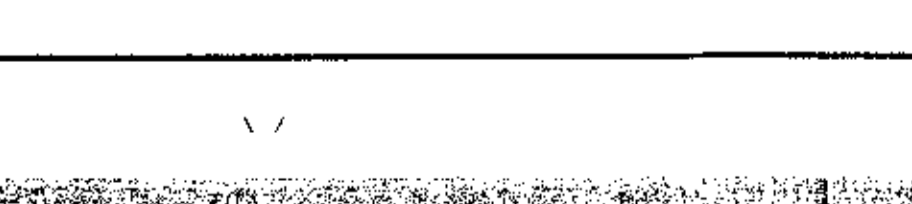
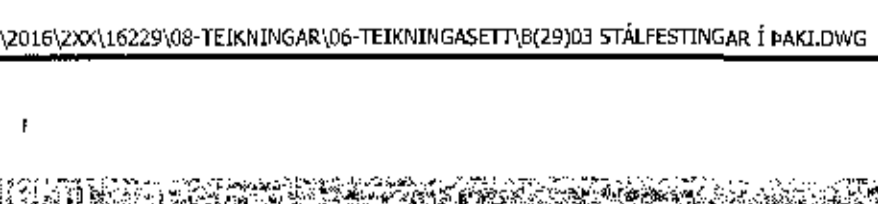
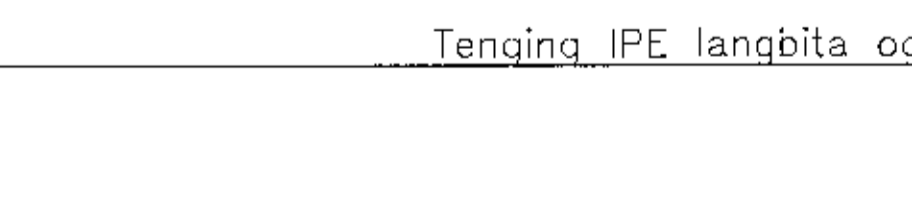
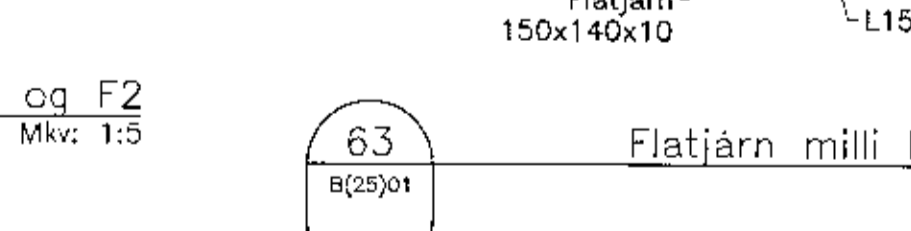
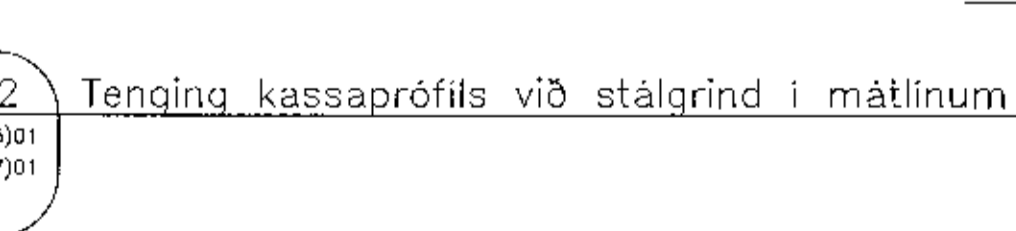
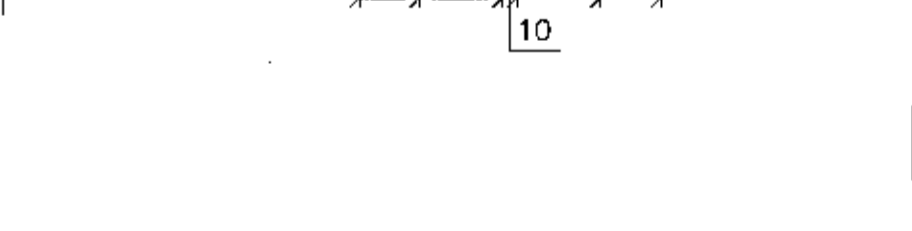
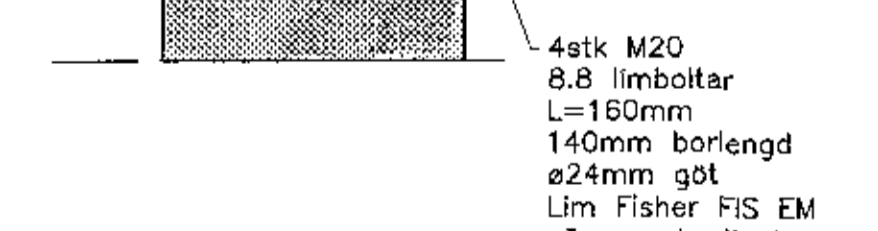
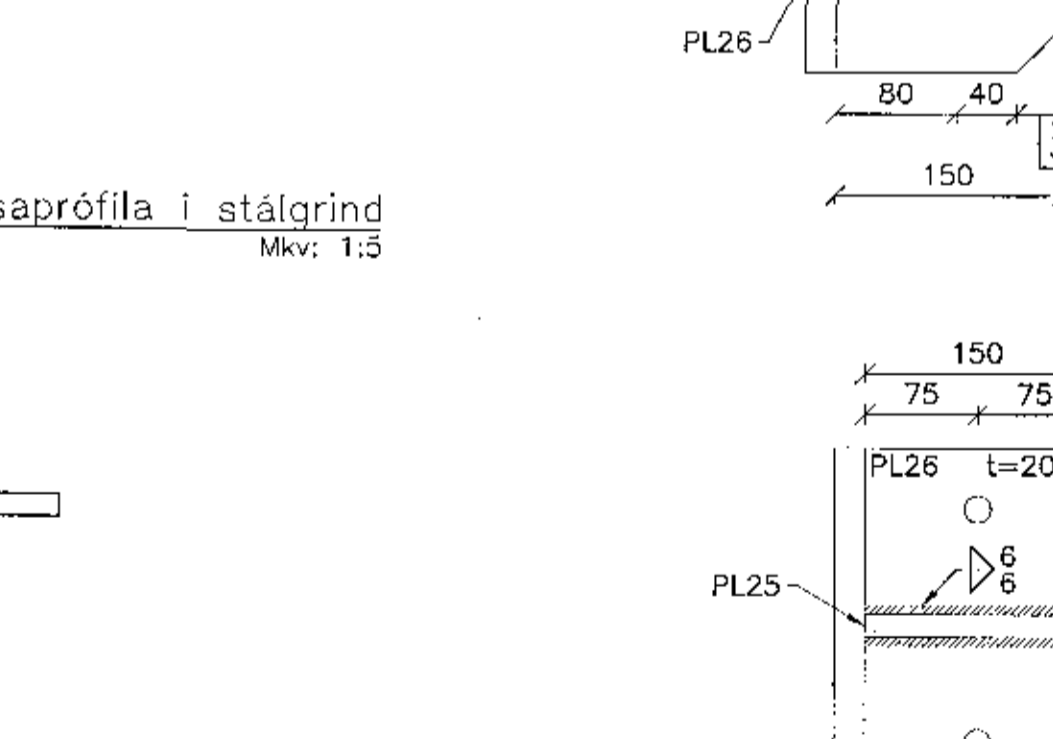
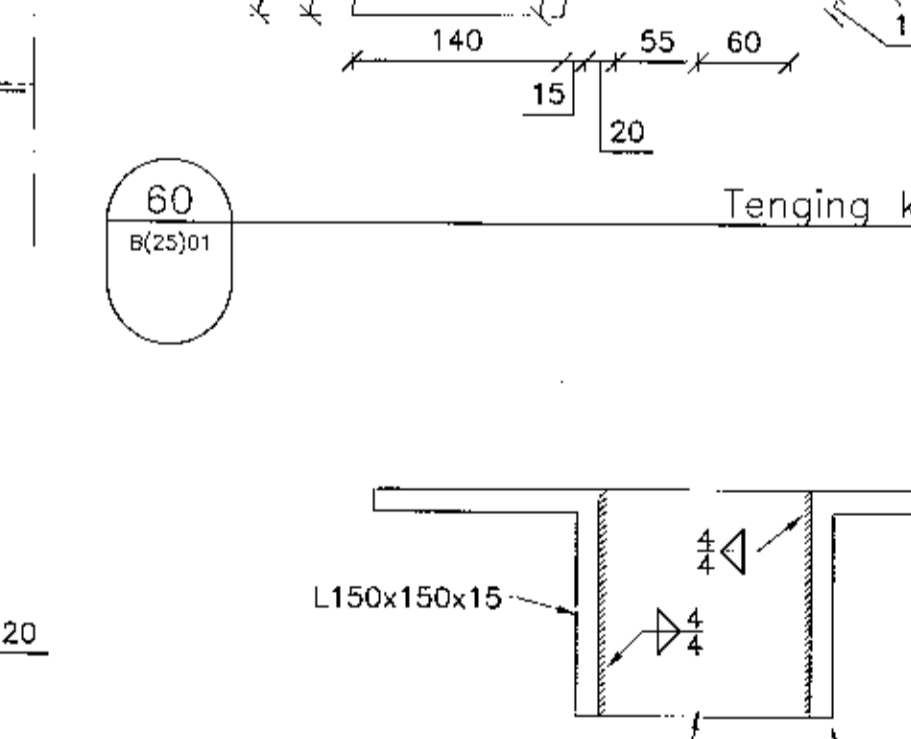
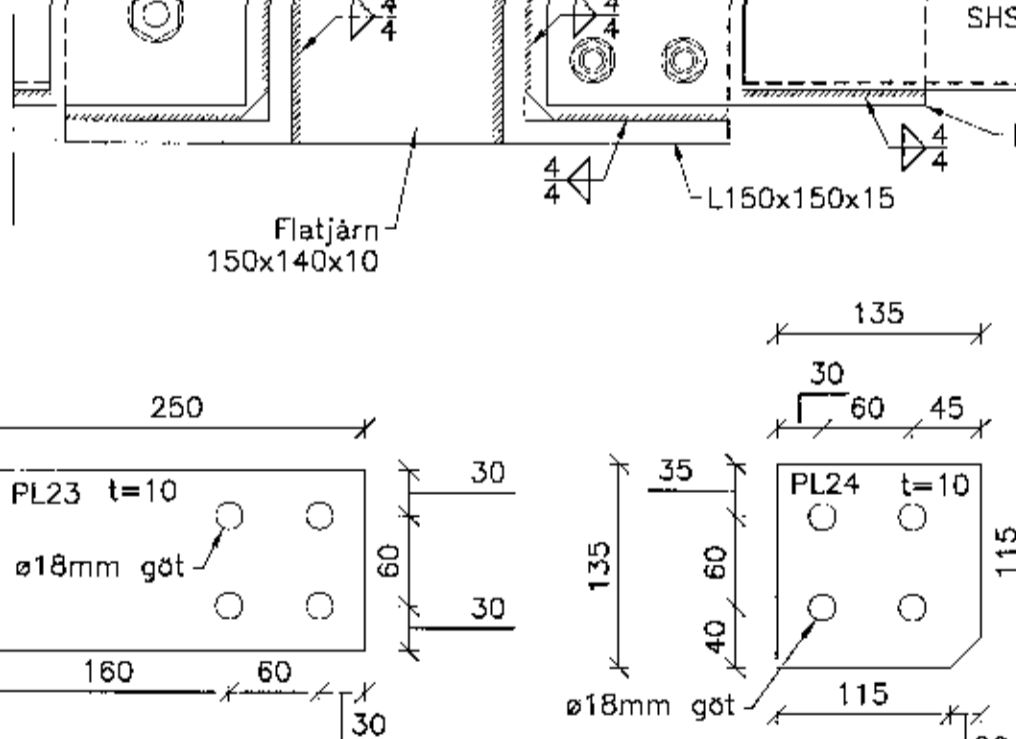
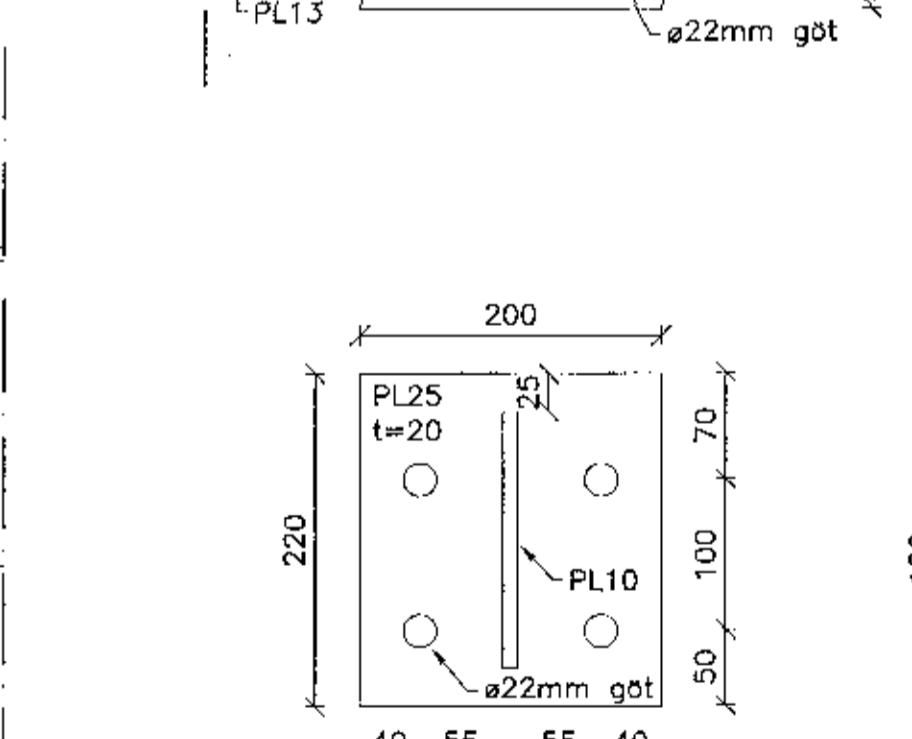
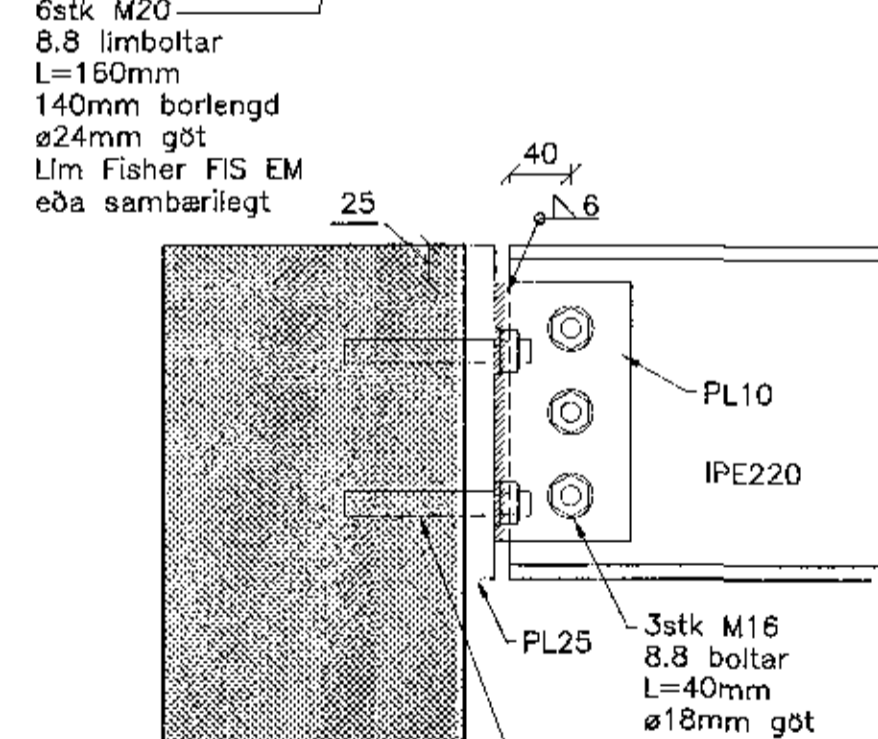
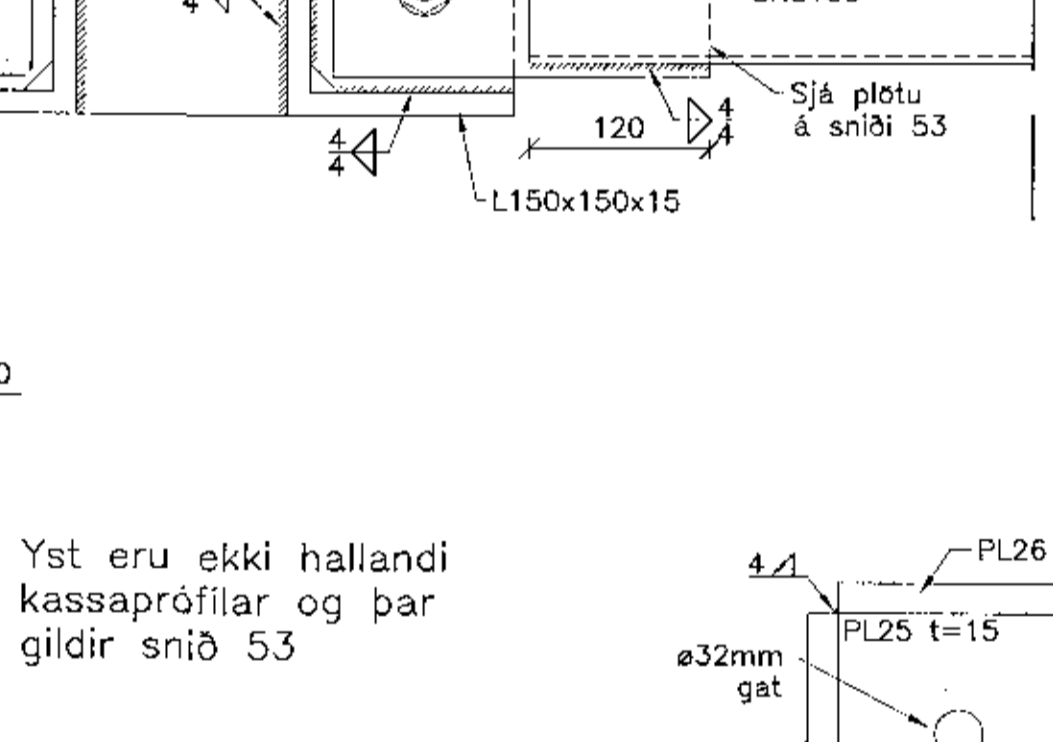
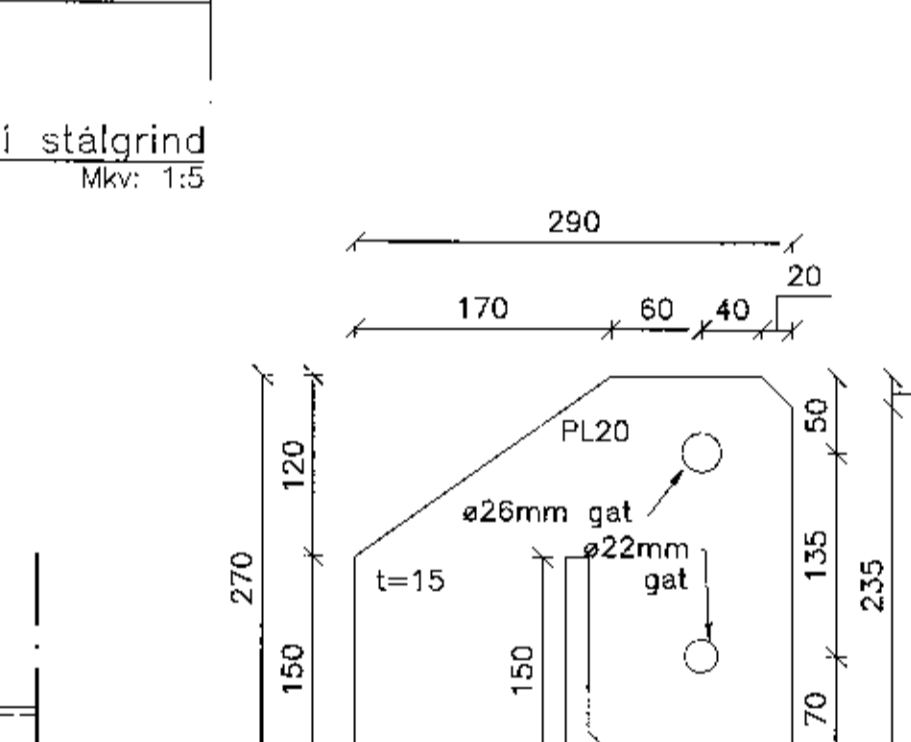
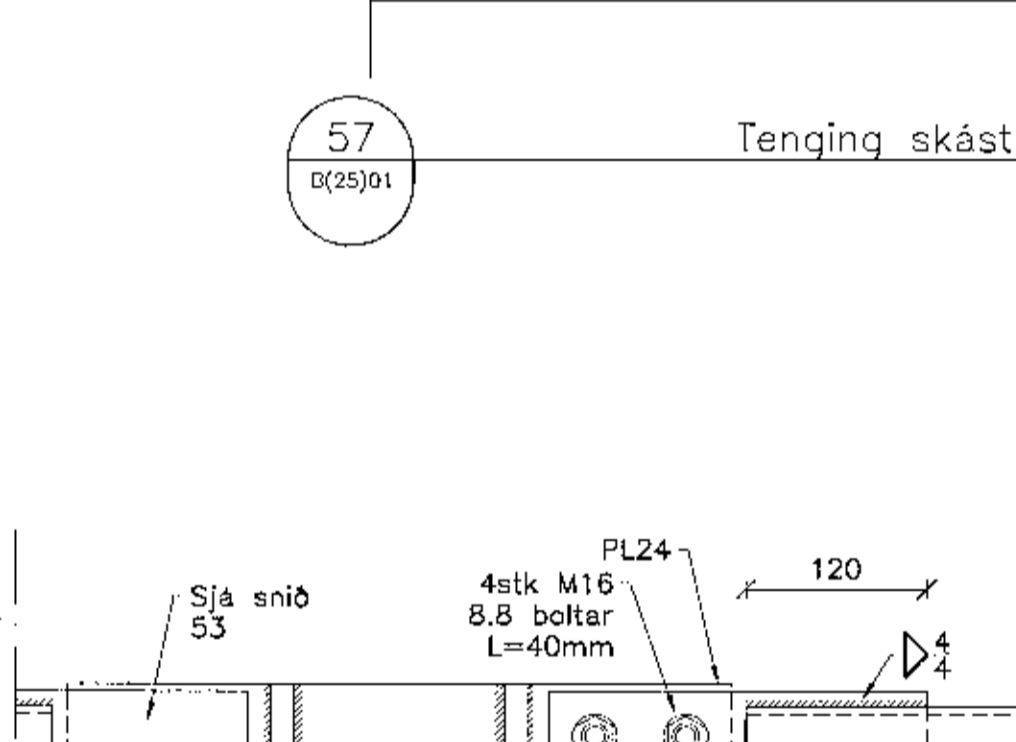
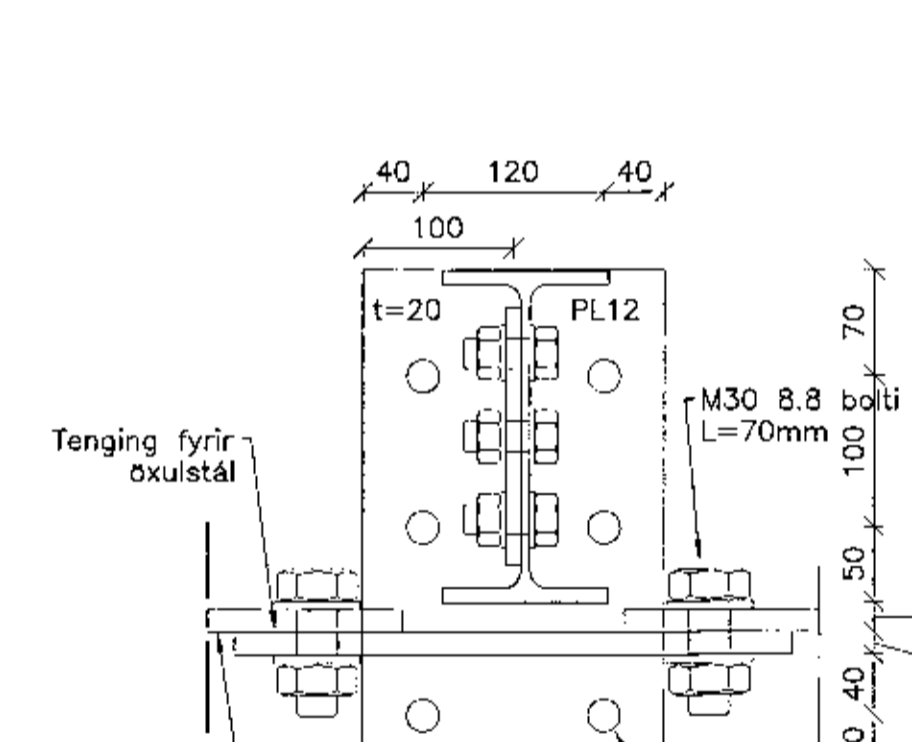
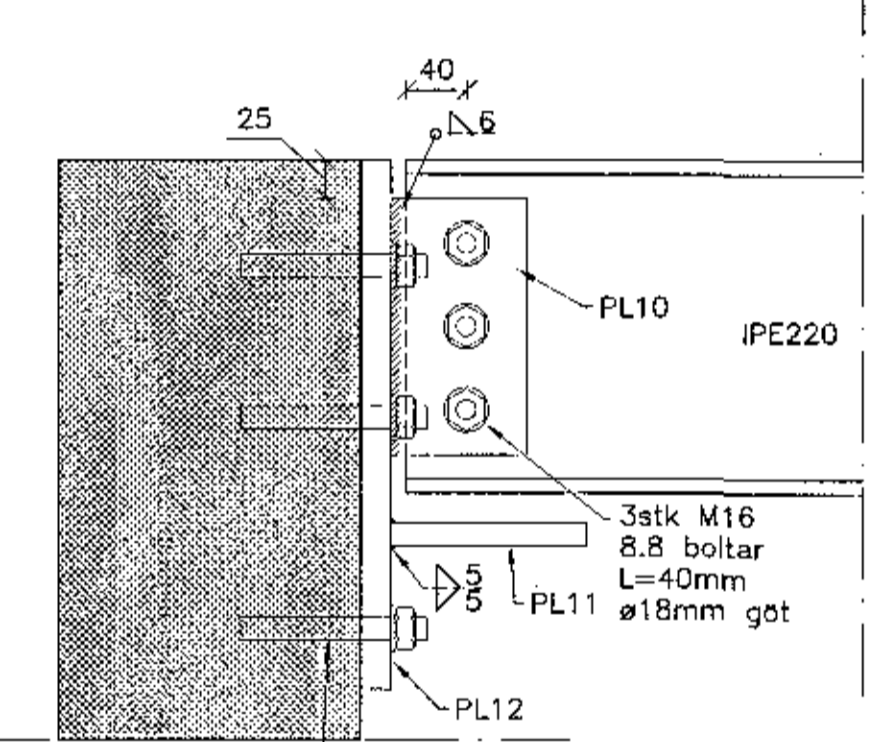
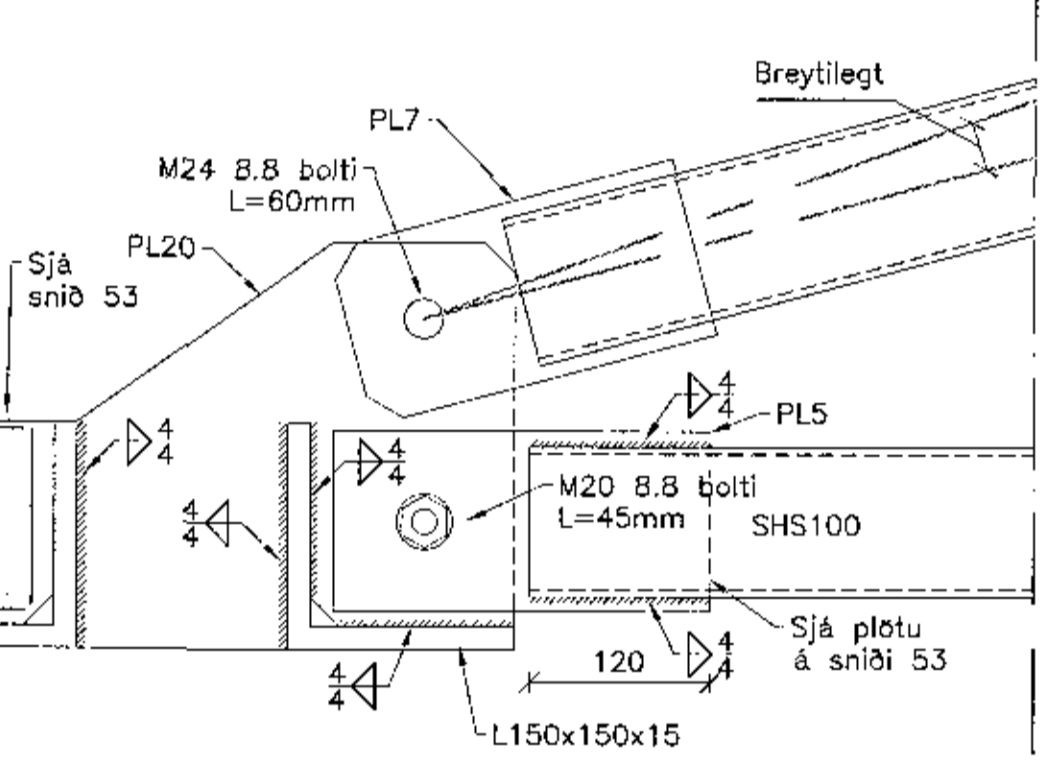
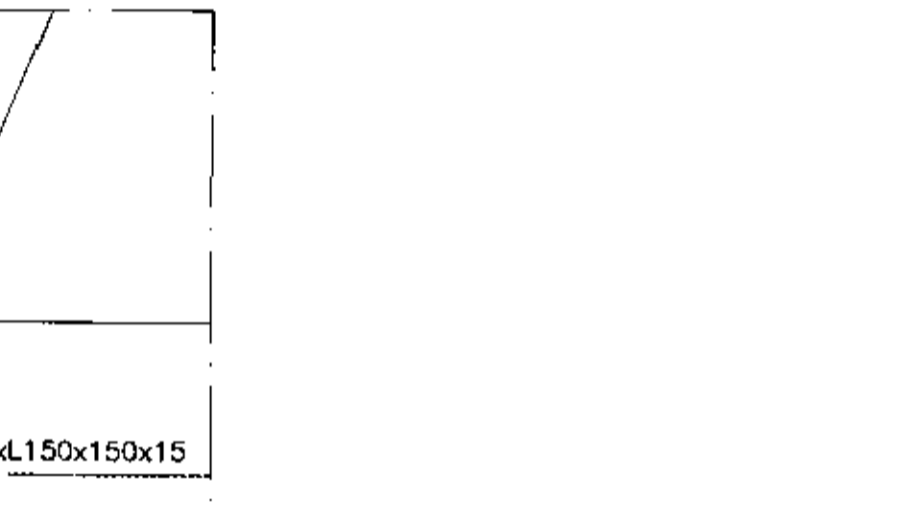
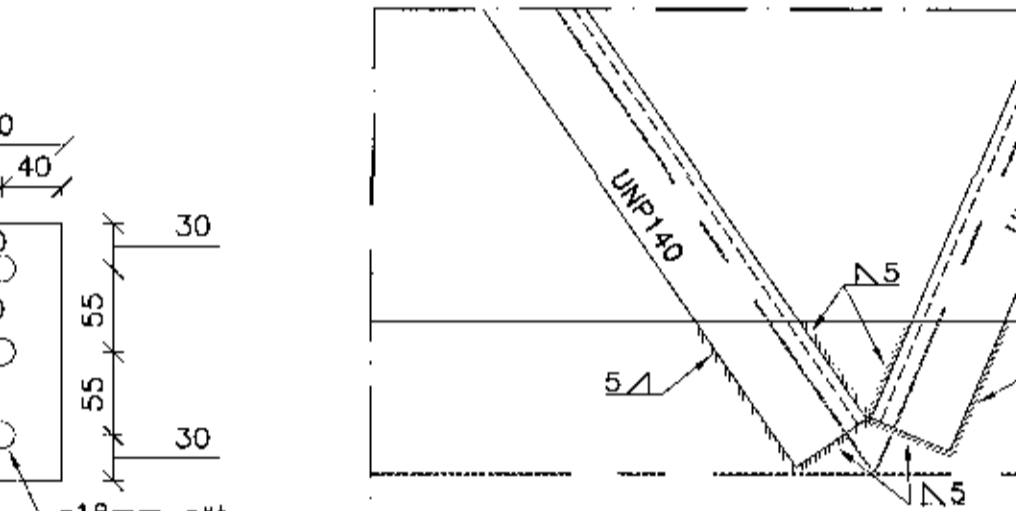
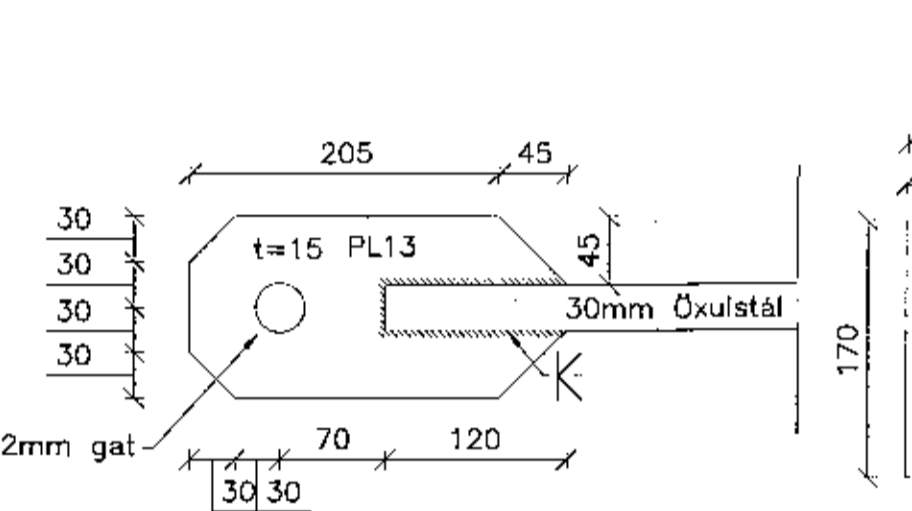
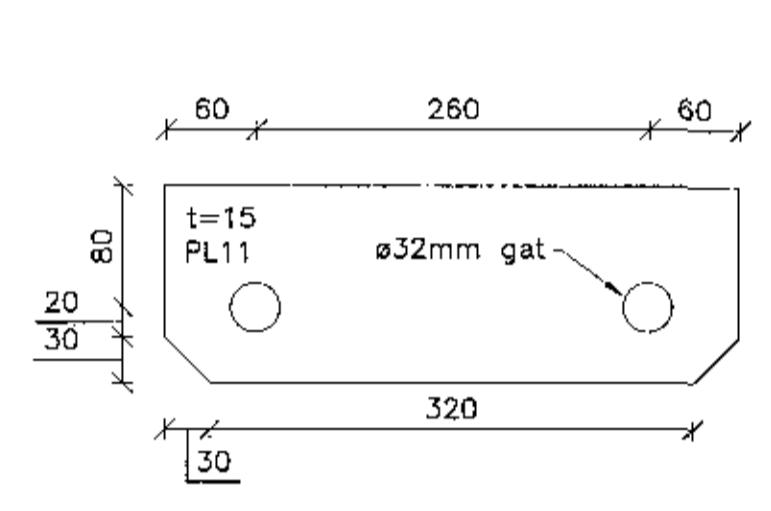

1	Frámærðartekning	16.08.17	HJE
Δ	Breytingar:	Dagss:	No.:
		Ískalið straut 88-80 138 Reykjavík Sími: 570-0000 Fax: 570-0005 www.hnit.is	
Handað:	AMG	Týðað:	JPG
Yfirleitt:	HJE		
Tölvaútskrá:	B(29)03 STÁLFESTINGAR Í ÞAKLÖG		
Nr.:	1311675479	Dagur:	16.08.2017
Samþykkt:	<i>Haukur Ólafur</i>		
Ásveillir, Íþróttamiðstöð Hauka Salur 2			
Búðarþöl			
Stálfestingar í þaki			
Verk nr.:	16229	Formt. blað:	A1
Mkv.:	1:5	Tekn. nr.:	
			Útg.:
			B(29)03 1