

NORÐVEGGUR, HLIÐARMYND. 1:50  
VEGGUR (VI)

Samþykkt þann  
19 MAY 2020  
Byggingardulfræði í Hafnarfirði  
F.h. Sigurður Steinn Jónsson

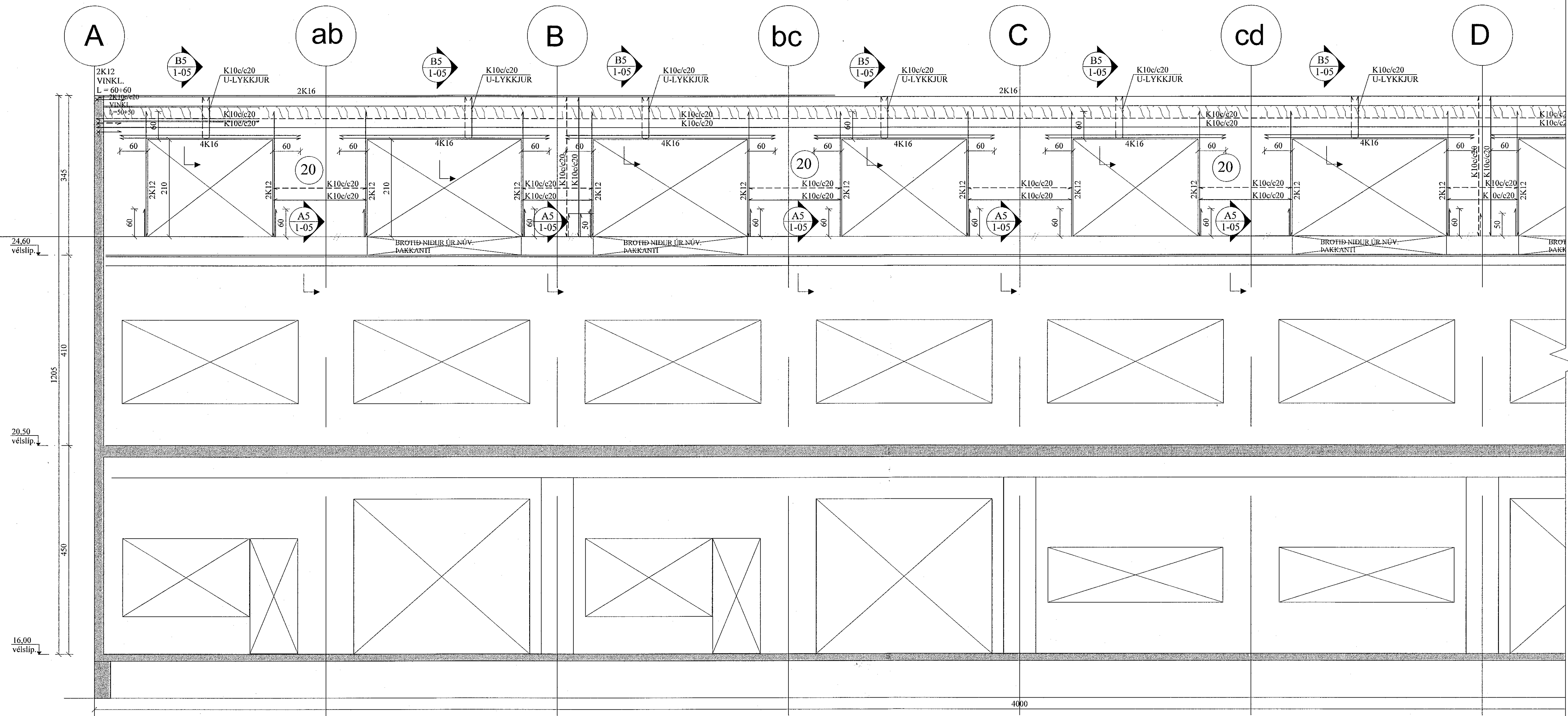

1-06

A5 SNID. 1:10

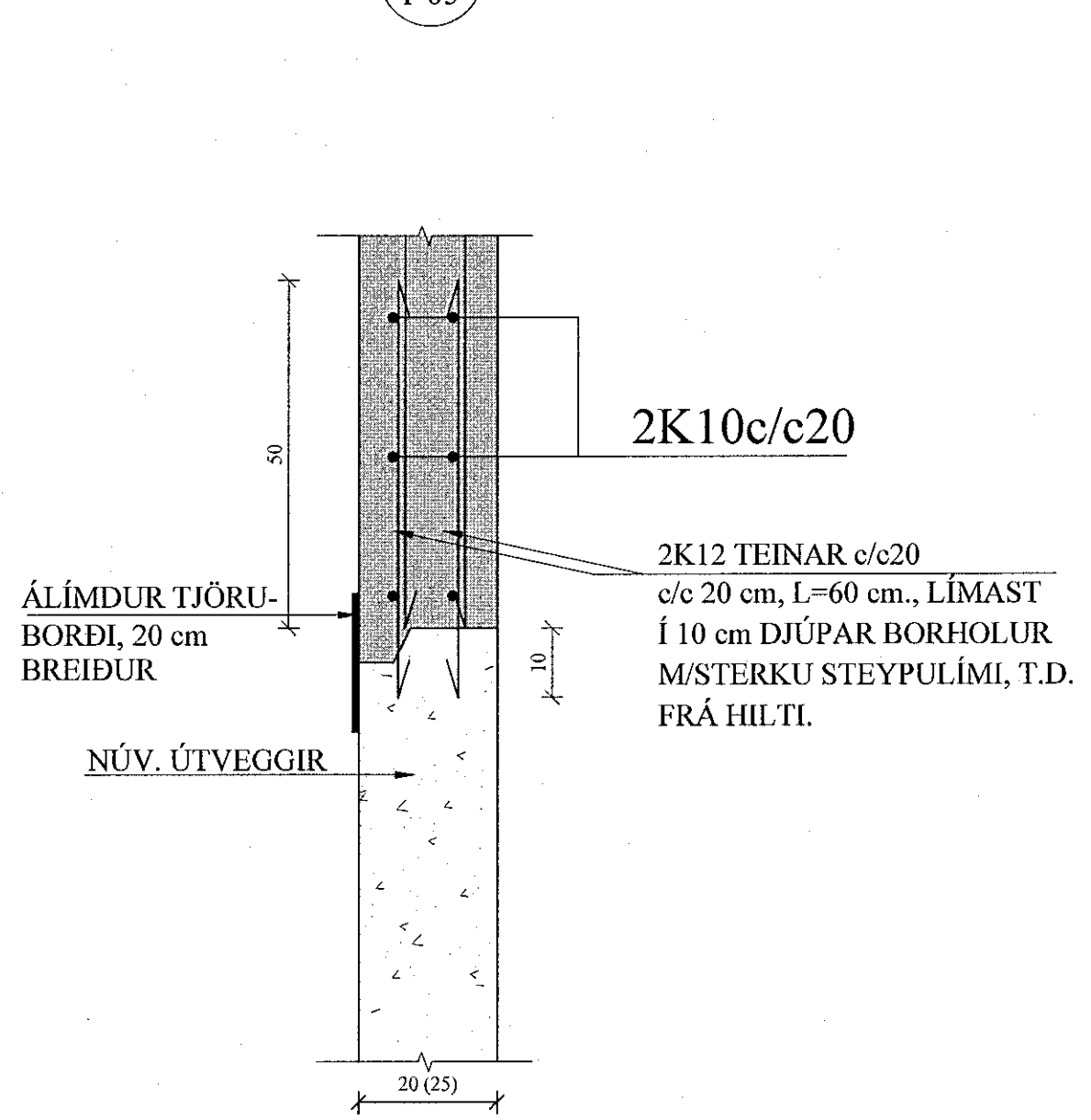

B5 SNID. 1:10

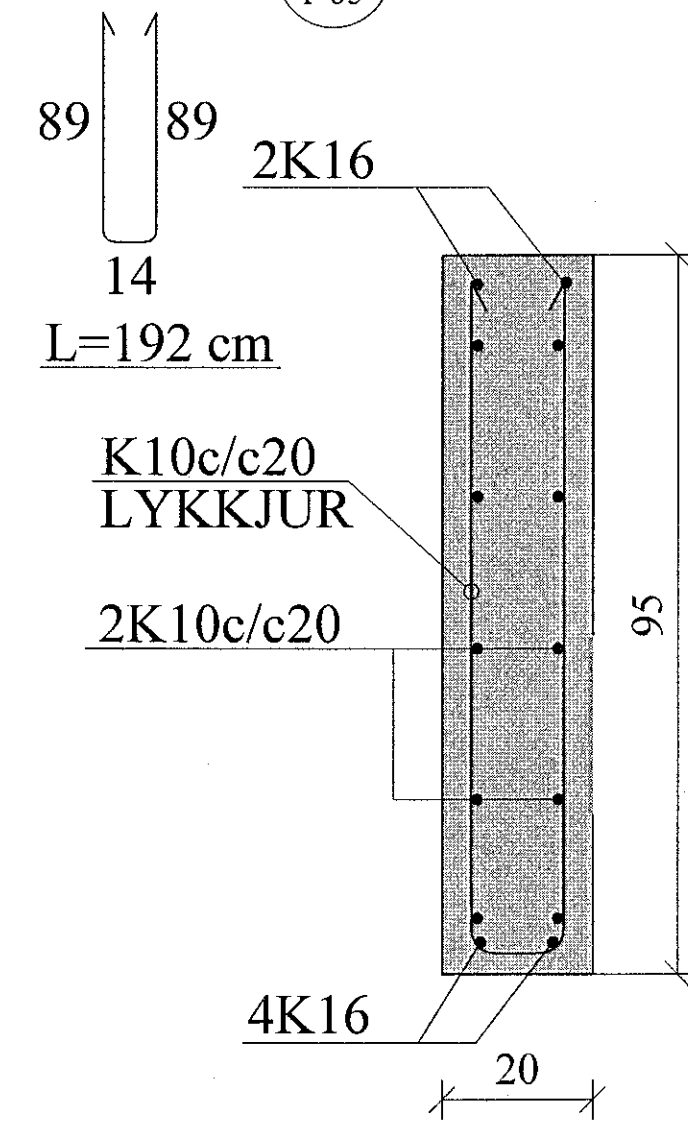

C5 SNID. 1:10

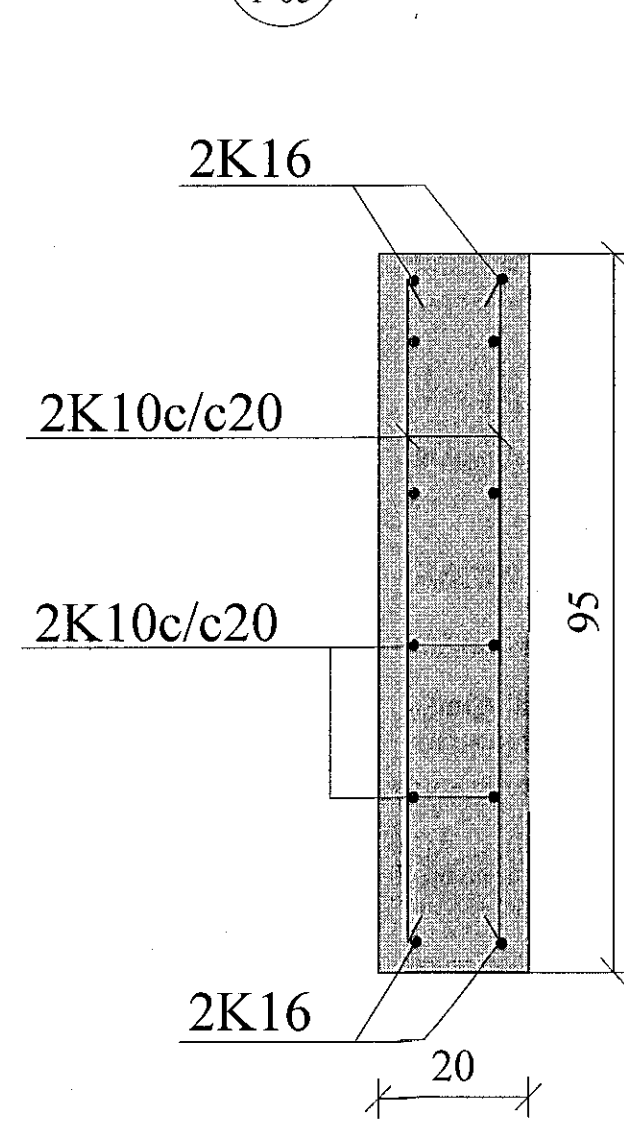

KENNIMYND

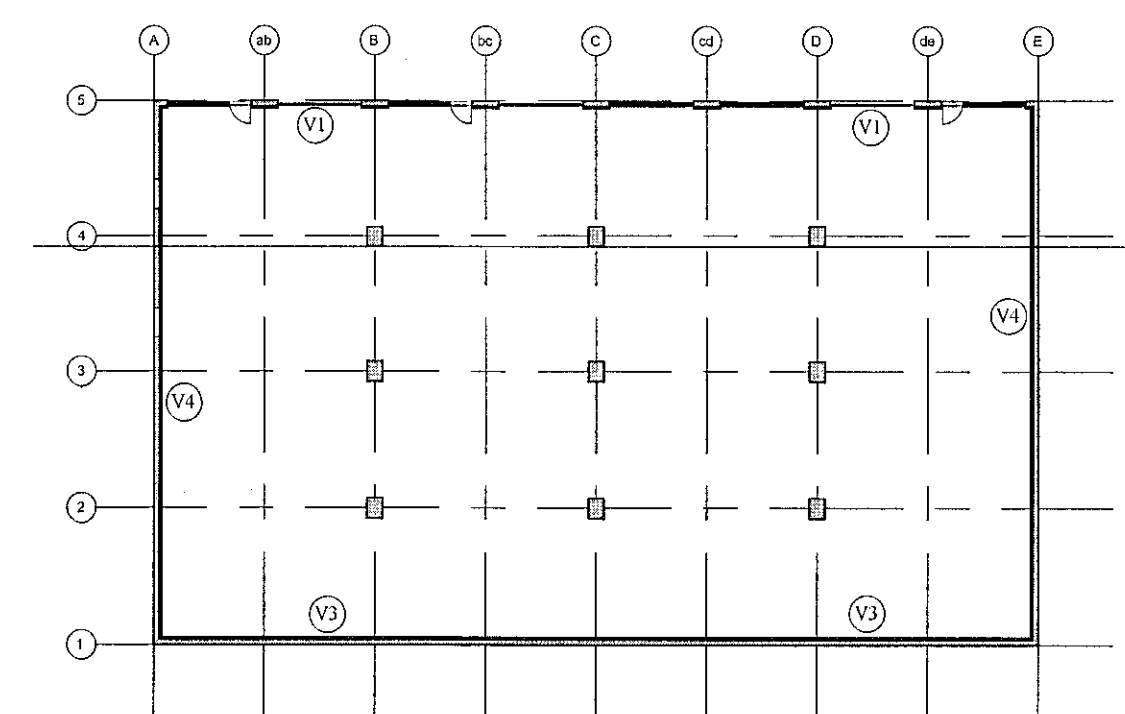

*[Signature]*  
BREYTINGAR

**TILVÍSANIR:**  
SKÝRINGAR..... SJÁ TEIKN. NR. 1-01  
**JÁRNBENDING Í VEGGJUM, NEMA ANNAD SÉ SÉRSTAKLEGA SÝNT:**  
**ÚTVEGGIR:** K10c/c20 lárétt, K10c/c20 lódrétt.  
**INNVEGGIR:** K10c/c25 lárétt og lódrétt.  
ÖLL LYKKJUBENDING K10c/c20, NEMA ANNAD SÉ SÝNT.  
ÖLL JÁRNBENDING ÚTVEGGJA SÉ 4CM FRÁ BRÚNUM, EN JÁRNBENDING INNVEGGJA Í MIÐJUM VEGG.

Reikn.	JKR	Sept. '19	Útgefnið:	01.10.2019
Teikn.	VP	Sept. '19	Kvarði:	1:50, 1:10
Ath.				
Samþ.				
<b>HVALEYRARBRAUT 39</b>				Nr. 1-05
Hafnarfirður				
Verkhliuti ÚTVEGGIR, HLIÐARMYNDIR.				
Verkefni Jóns Kjöglarsson ehf. Árnúla 19 108 Reykjavík Sími: 537-0002 Gsm: 772-3154 f: 54037-0300 Netfang: jkr@s4@gmail.com				