

This is not shown on drawing -216

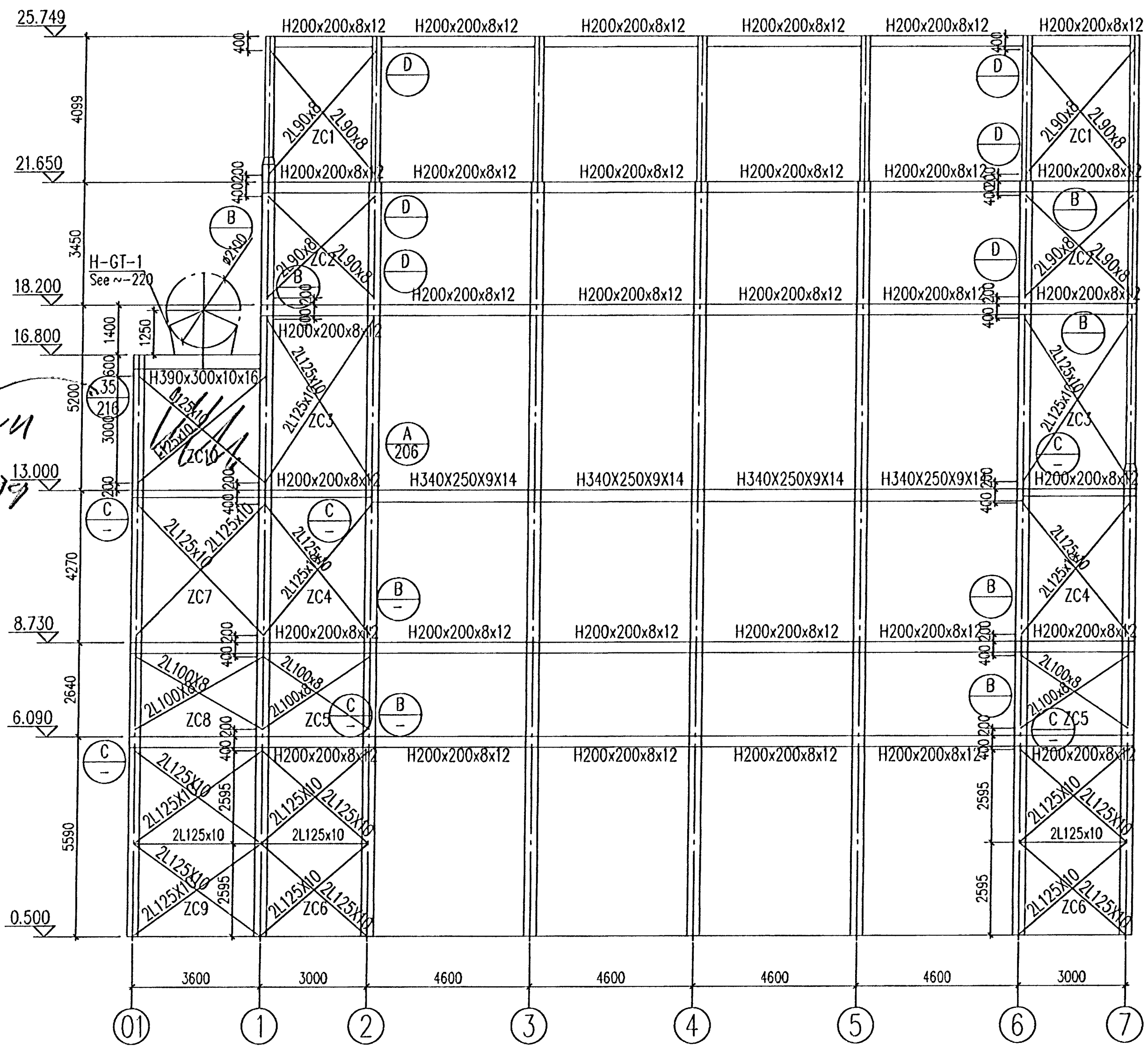

CONNECTIONS OF ANGLES ARE SHOWN ON DRAWINGS 214 AND 215

1--1 (KJ-A, KJ-C) Scale 1:100

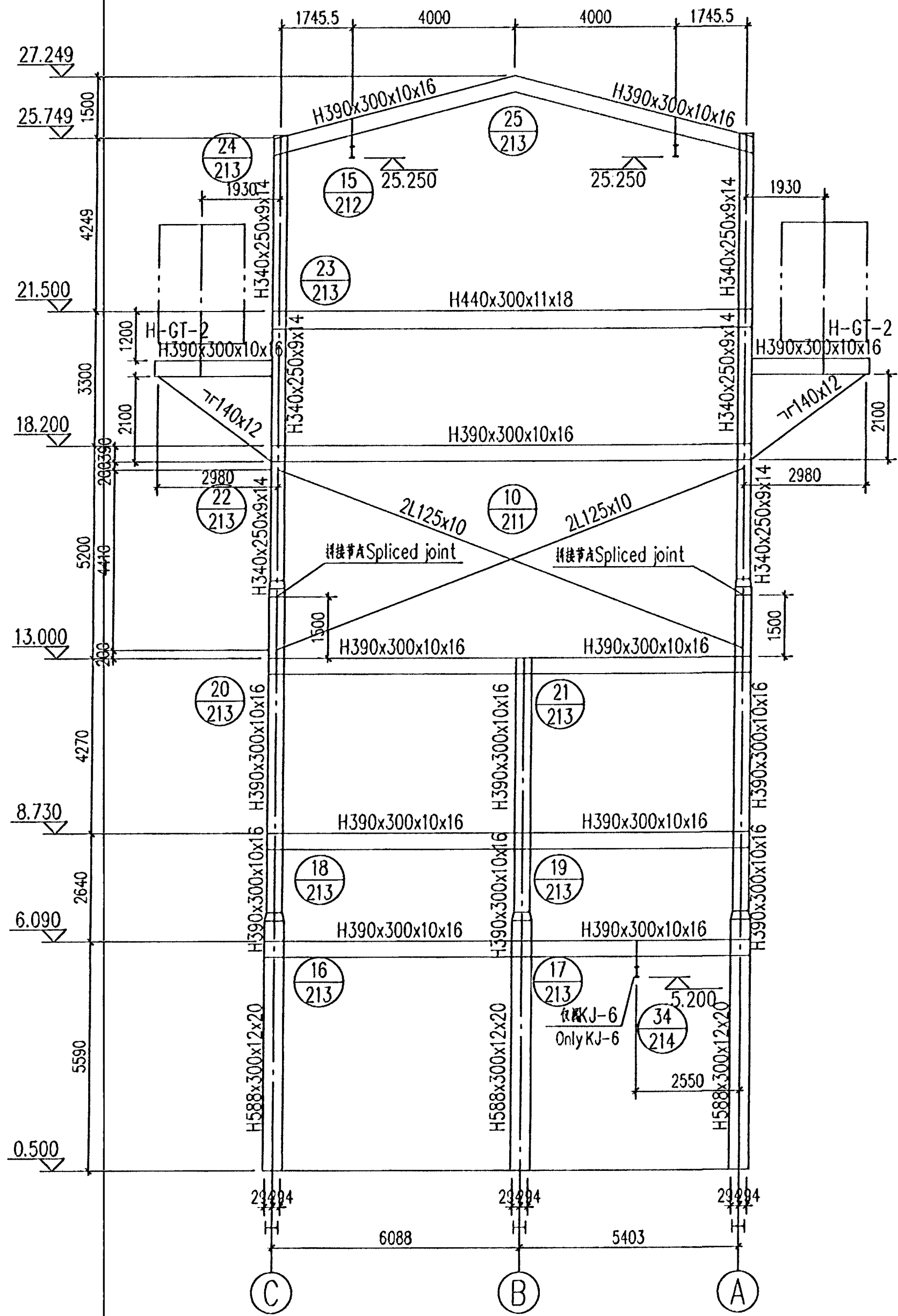

KJ-2 (KJ-6) Scale 1:100

Sambýkkt þann 05. Júní 2012

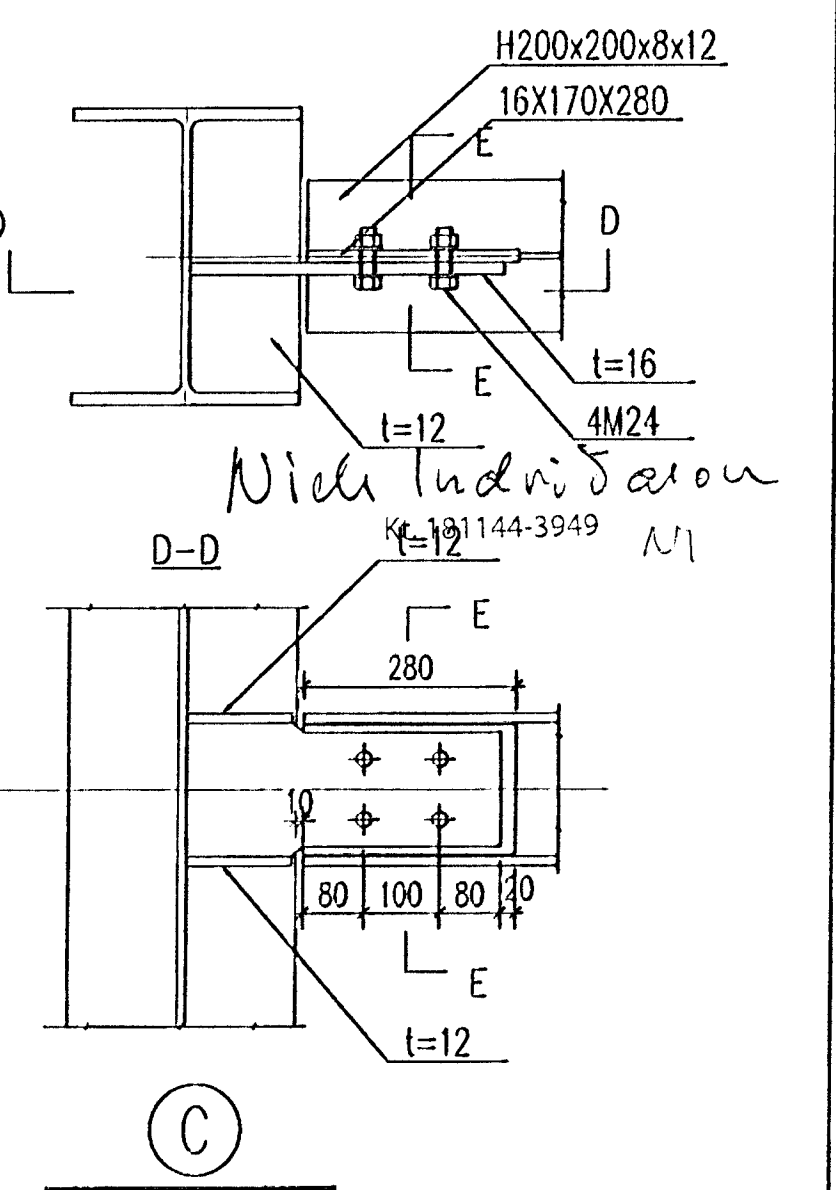

Scale 1:10

Nuts welded to the inner side of the beams/plate (side facing gridline B)

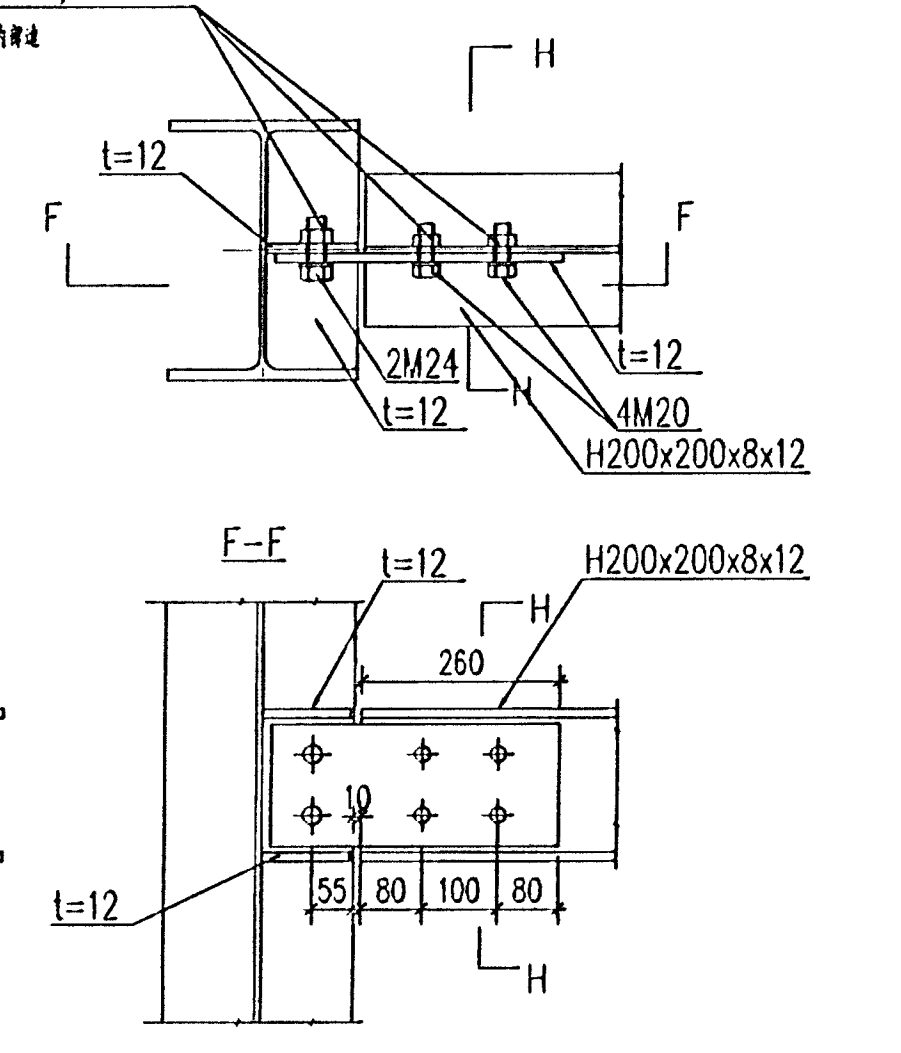

Scale 1:10

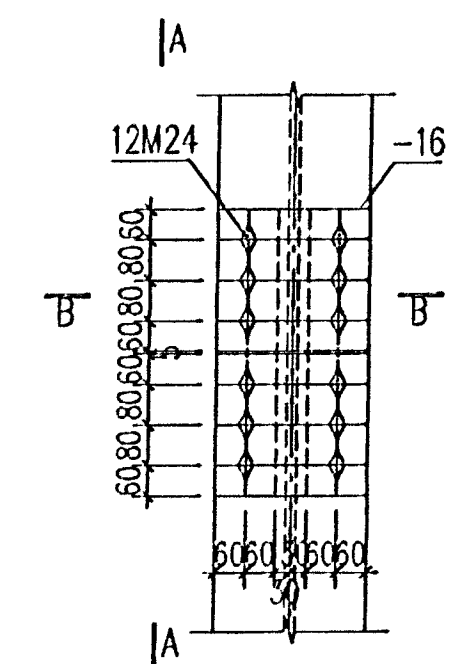

H390x300x10x16 拼接节点 Spliced joint of H390x300x10x16 Scale 1:15

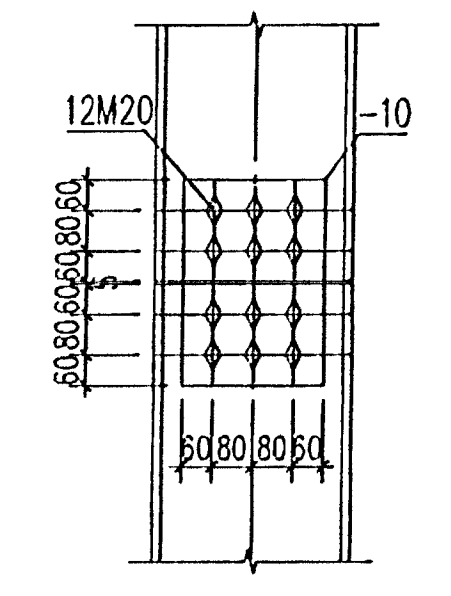

A--A Scale 1:15

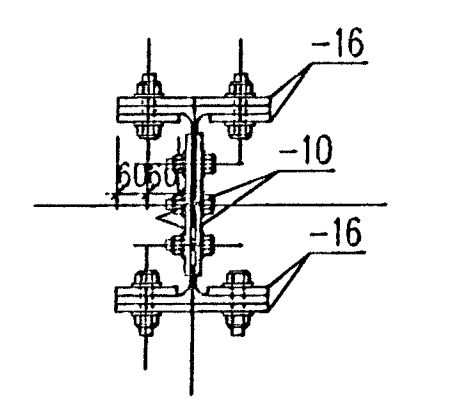

B--B Scale 1:15

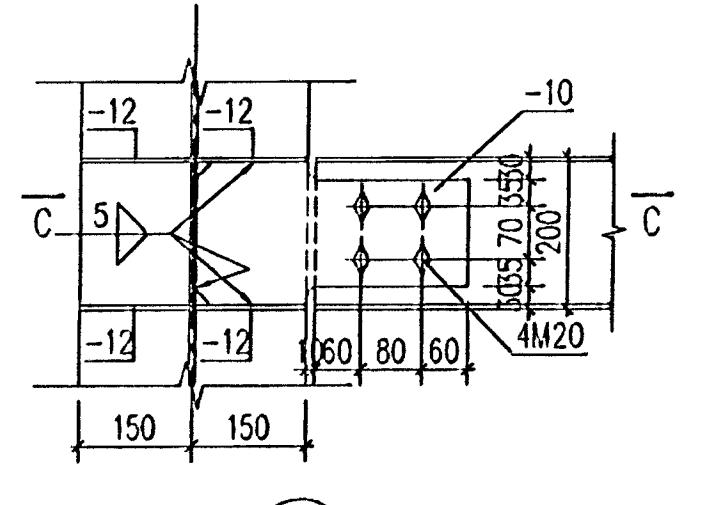

Scale 1:10

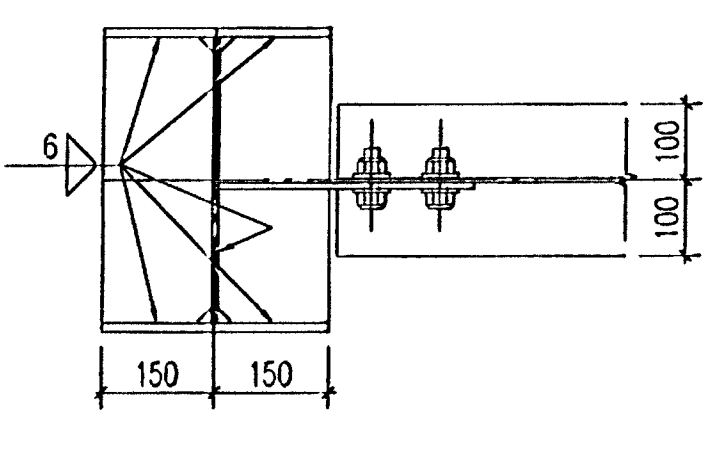

C--C Scale 1:10

说明
1. 相关说明见 IPU-432-ZA-011-203
NOTES
1. FOR THE RELATIVE NOTES, SEE DWG. IPU-432-ZA-011-203

Skýringar:
Legend:

VENDOR DOCUMENT STATUS	
<small>Permission to proceed does not constitute acceptance or approval of design details, calculations, analysis, test methods, or materials developed or selected by CONTRACTOR / VENDOR, and does not release CONTRACTOR / VENDOR from full compliance with contract obligations.</small>	
1 <input type="checkbox"/> WORK MAY PROCEED.	4 <input checked="" type="checkbox"/> REVIEW NOT REQUIRED. WORK MAY PROCEED.
2 <input type="checkbox"/> REVISE AND RESUBMIT. WORK MAY PROCEED SUBJECT TO INCORPORATION OF CHANGES.	5 <input type="checkbox"/> CANCELLED / SUPERSEDED.
3 <input type="checkbox"/> REVISE AND RESUBMIT. WORK MAY NOT PROCEED.	6 <input type="checkbox"/> FOR INFORMATION.
REVIEWED BY: <i>[Signature]</i>	DATE: <i>24/12</i>
DOCUMENT No: IPU-432-011-ES-VD-1063-sub01	REV: <i>[Blank]</i>

Sl. No.	Rev. No.	Issued For	Issued Date	By	Checked By	Approved By	Approved Date
7							
6							
5							
4							
3	Issue for review	2012/3/23	BZC	LOS			
2	Issue for review	2011/10/17	HJ	TYF			
1	Issue for review	2011/08/03	HJ	TYF			

This drawing is the property of Rio Tinto Alcan Iceland Ltd. and handed out for personal use only. It may neither be copied nor made available to others without permission of Rio Tinto Alcan Iceland Ltd. The receiver is liable for any misuse.

Scale: 1:100, 1:15
Dimensions without tolerances according to ISO 2768-M medium.

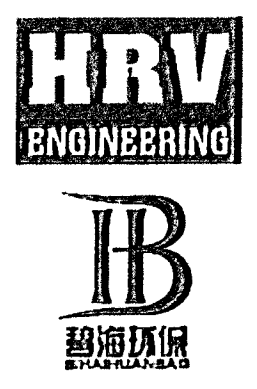

Designing / Date	3.5.2011
Drawn / Designed	HJ
Checked / Supplier	HJ
Checked by Environmental Protection Equipment Dept	
Technical verification / Supplier drawing	
IPU-432-ZA-011-204	
Stamp / Approved	
Drawn / Part of	

IPU-430 Gas Treatment Centers		Flokkur nr.:	Boð nr.:	Heiti bl. nr.:
Steel structure		Kostnaður - Ccno. / BSHnr. - Eqno		
GIC1a Filter Unit, Frames KJ-A, KJ-C, KJ-2 And KJ-6		AKS		
Sections and Details		AKS		
Rio Tinto Alcan		ISAL	ISAL / Drawn of ISAL	Erstj./Rev
ISAL 19-222 Hafnarvegur 106 Reykjavík		ISAL	ISAL / Drawn of ISAL	C
ISAL 19-222 Hafnarvegur 106 Reykjavík		ISAL Stamp / Date		