

EMBEDDED STEEL ON EDGES OF OPENING. 1:25

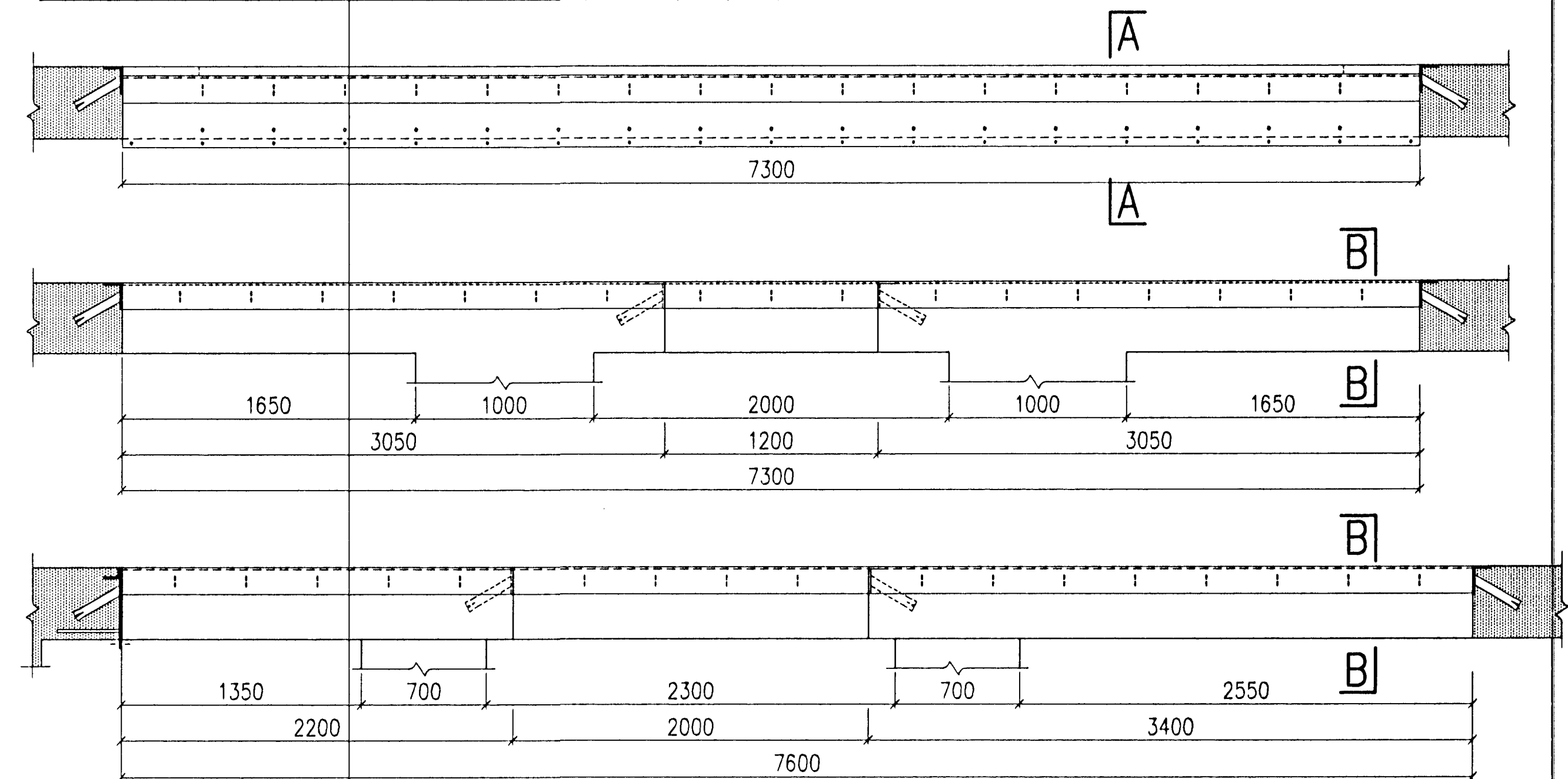

COLUMNS. 1:25

QUANTITY: 29

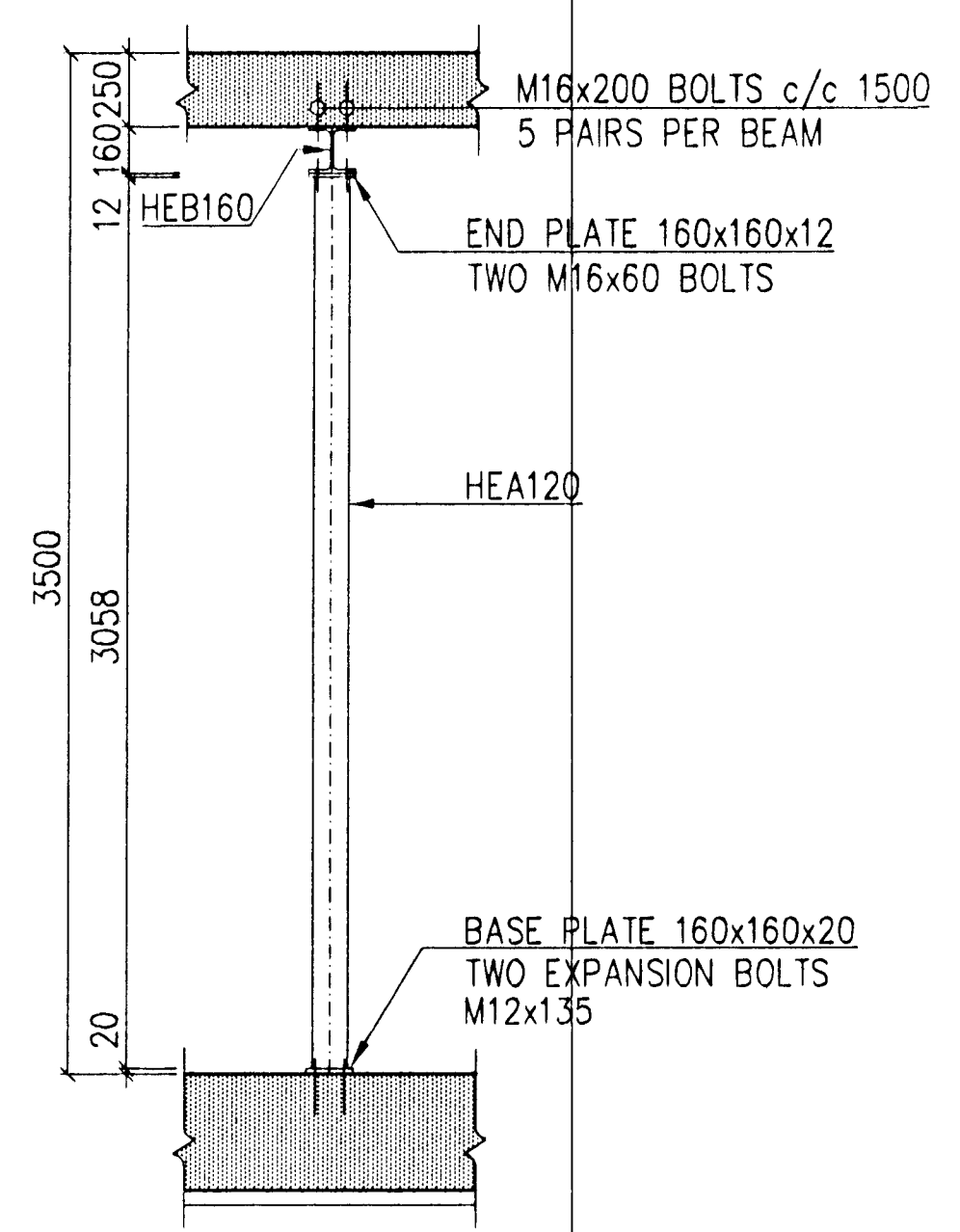

8 PC. STEEL PLATES, 3000x800x30. PLACED ON A BED OF SAND. SAME APPLIES FOR FURNACE 28.

A-A. 1:10

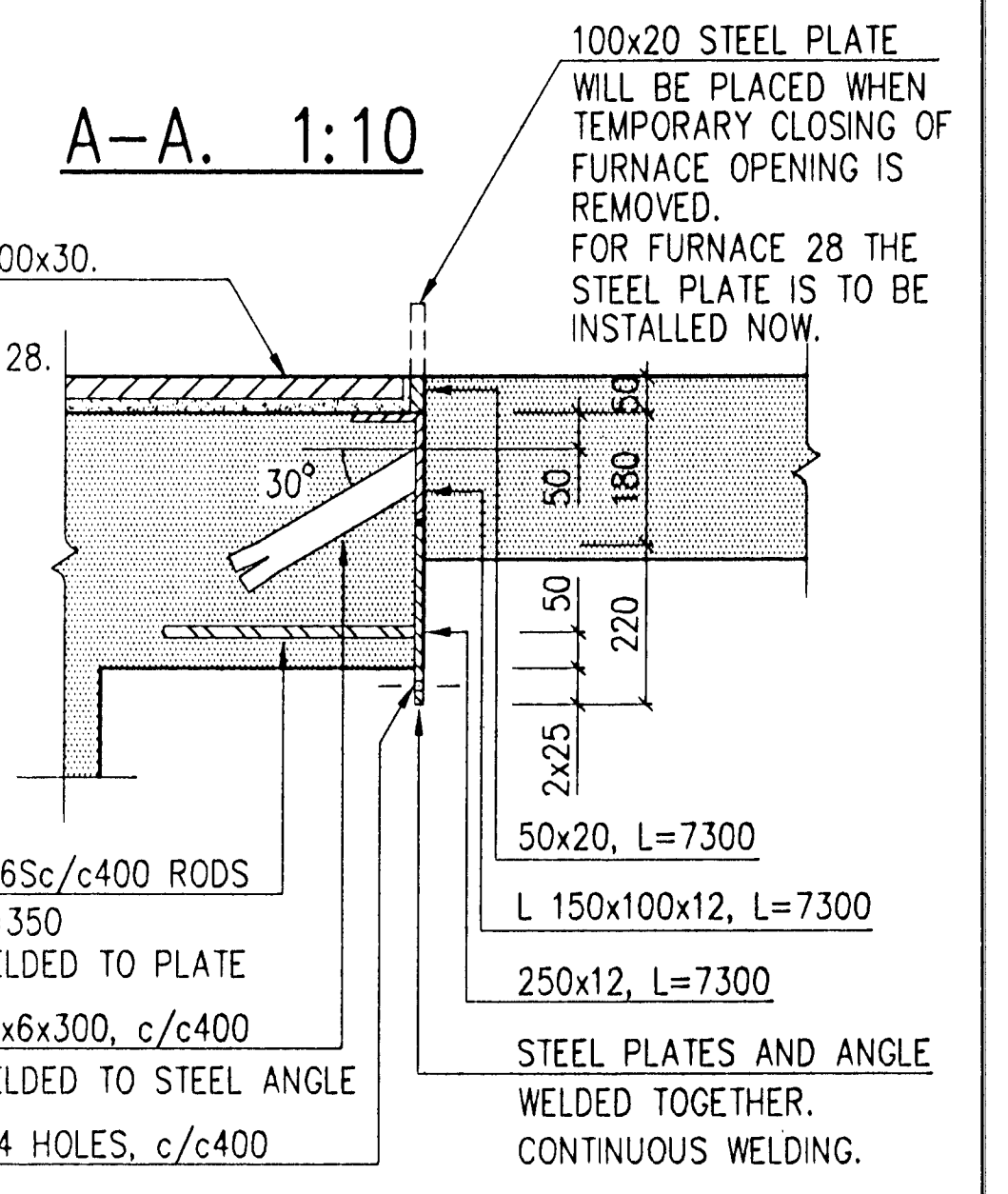

B-B. 1:10

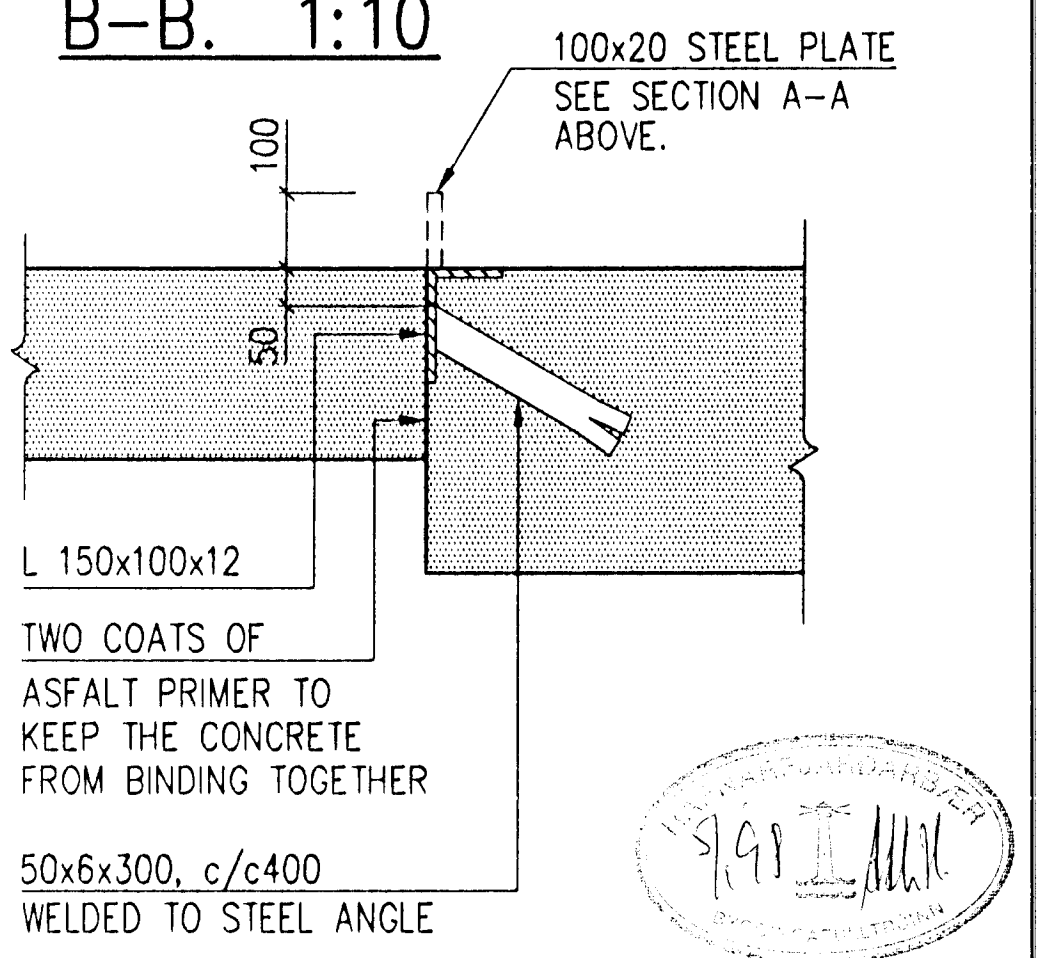

REV. NO.	DATE	REVISION	BY	APP.	REV. NO.	DATE	REVISION	BY	APP.	NOTES
2	2.1.1997	SECTION A-A. RECESS CHANGED FROM 80 TO 50MM	UH							
1	15.8.1996	ISSUED FOR CONSTRUCTION	UH							
0	20.5.1996	ISSUED FOR TENDER								

This drawing is our property and given for personal use only. It may not be copied or made available to others without our permission. The receiver is responsible for any misuse.

ICELANDIC ALUMINIUM COMPANY LTD.

ALUSUISSE ALESA

ALUSUISSE ENGINEERING LTD. ZÜRICH SWITZERLAND

VERKFRÆDISTOFAN ONN SF. TÆKNITHJONUSTAN SF.

DRAWN 17.5.1996 HHH
APPROVED 17.5.1996 UH
PROCESS
PROJECT
SCALE 1:25
FORMAT A1

CASTHOUSE EXTENSION
STRUCTURAL
OPERATION FLOOR. OPENING FOR FURNACE 29. TEMPORARY CLOSING.

79000-34218

193.418

2