

AFSTÖÐUMYND
1:500

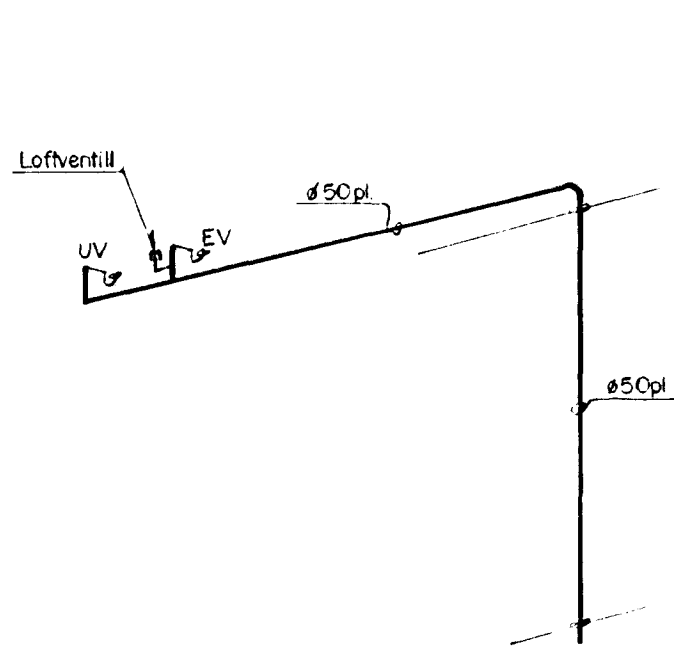

STAMMI A
1:50

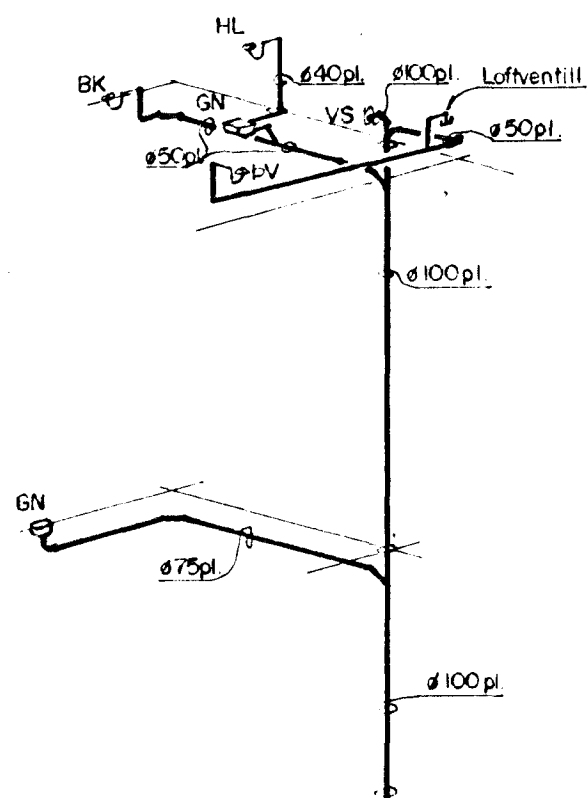

STAMMI B
1:50

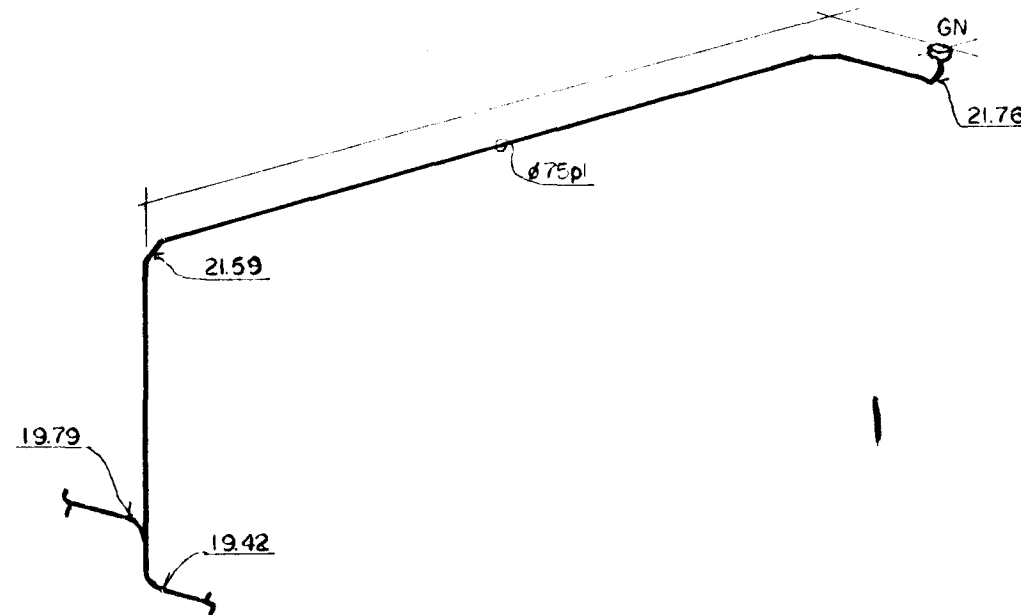

STAMMI C
1:50

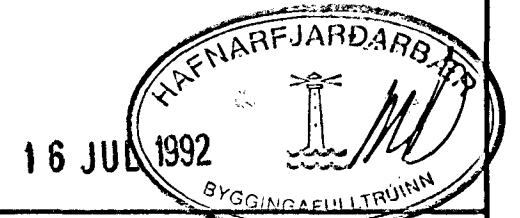

Breytingar			Nr.	Dags.	Nafn	VESTURHOLT 8 PÁLL R. SIGURÐSSON Vélaverkfræðingur Hringbraut 60 Hafnarfjörð sími 650850	H. T. S. M. 1:80 / 1:500 Nr. 014.001 Dags. 17.07.92 <i>Páll R. Sig.</i>
Nr.	Dags.	Nafn					
						GRUNNMYND	
						FRÁRENNSLISLAGNIR	