

SÖKKULSKAUT
TENGIBOX H:400

SÖKKULSKAUT
DÆMIGERÐUR FRÁGANGUR

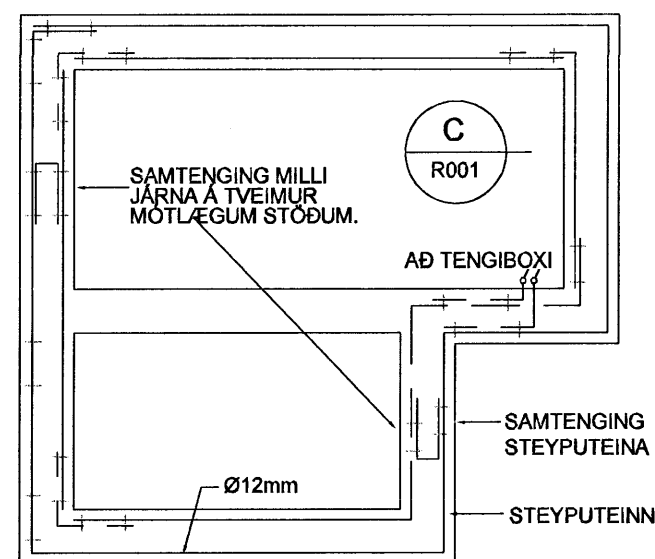

GRUNNMYND SÖKKULVEGGJA

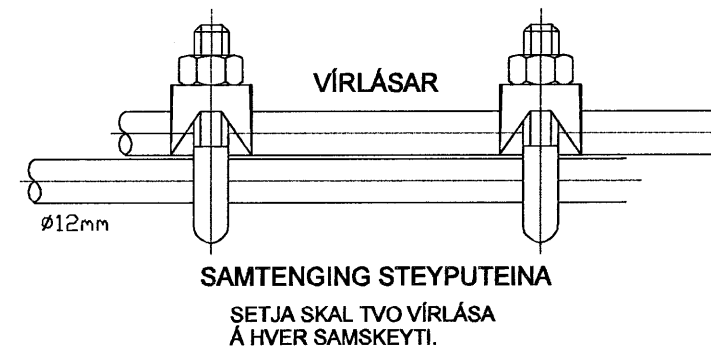
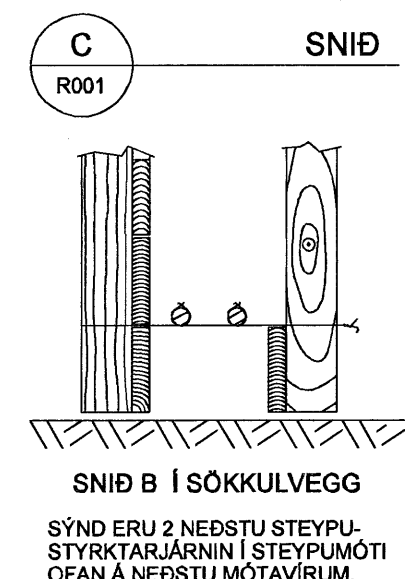

SKÝRINGAR:

SÖKKULSKAUT SKAL GANGA FRÁ MED ÞVI AD TENGJA TRYGGILEGA SAMAN TVO NEDSTU JÄRNIN Í SÖKKLI MED VIRAKLEMMU EDA MED RAFSBUJ ALLAN ÚTHRINGINN.

--- SÖKKULSKAUT

Sigurbjartur Halldórsson
0601 11 090909
Mott. 8/1 2006
SBS

Útg. Dags. Skýring Hannab/Virfarb

VSB

VERKFRÆÐISTOFA

BAEJARHAUN 20 · 220 HAFNARFJÖRDUR · KENNIT. 710798-2899
vsb@vsb.is · Sími 585 8600 · Fax 585 8610 · www.vsb.is

Áritun sérhönduðar
Ragnar Viktor Karlsson kt:220470-5129 RVK

Verkefni
LÖNSBRAUT 1
HAFNARFIRDI

Verktali
Rafkerfi
Sökkulskaut
Grunnmynd og skýringar

Hannab	Teknað	Virfarb	Kvartel	/A1	Síða
BSG	BSG	RVK	1:100		-
Dags	Verkefni	Tekning			Útgáfa
13.12.2006	06762	R002			-