

A SNID  
10-25 1:20

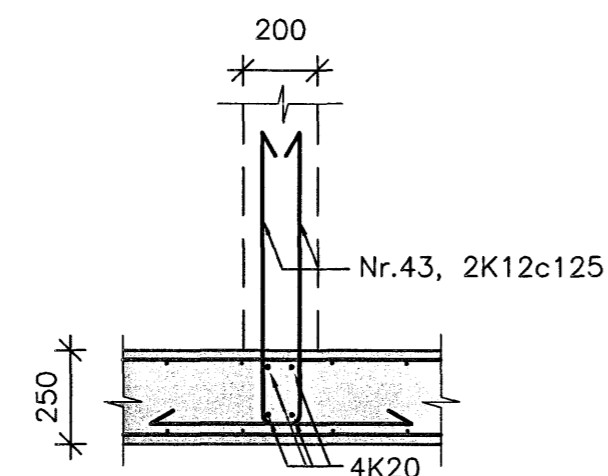

B SNID  
00-25 1:20

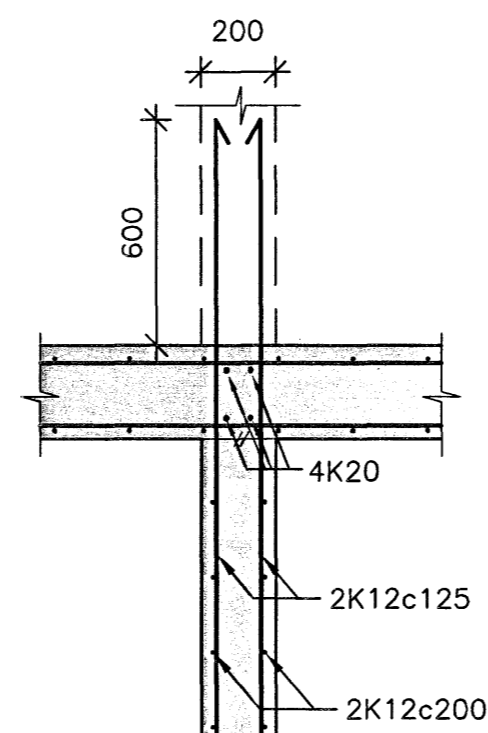

C SNID  
01-05 1:20

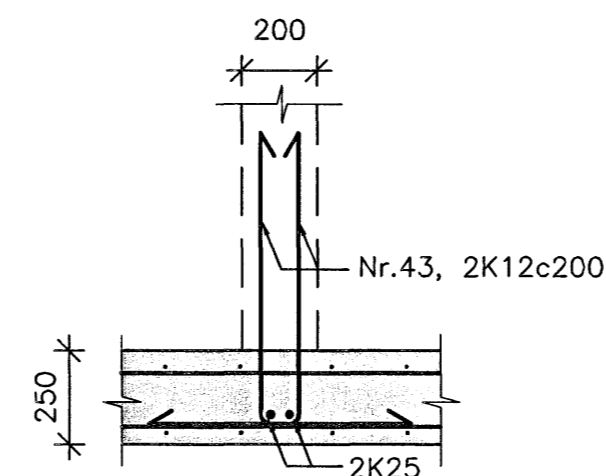

D SNID  
01-05 1:20

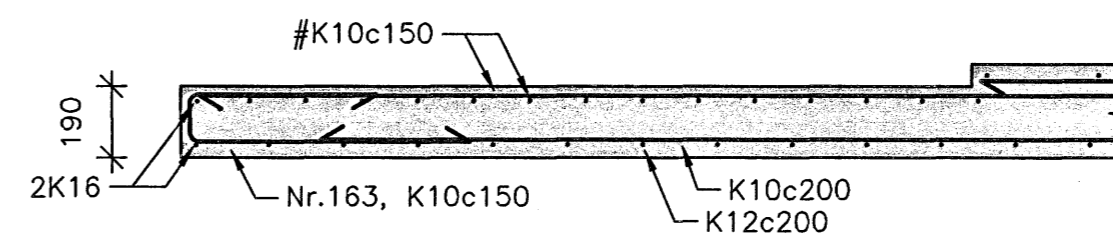

E SNID  
10-62 1:20

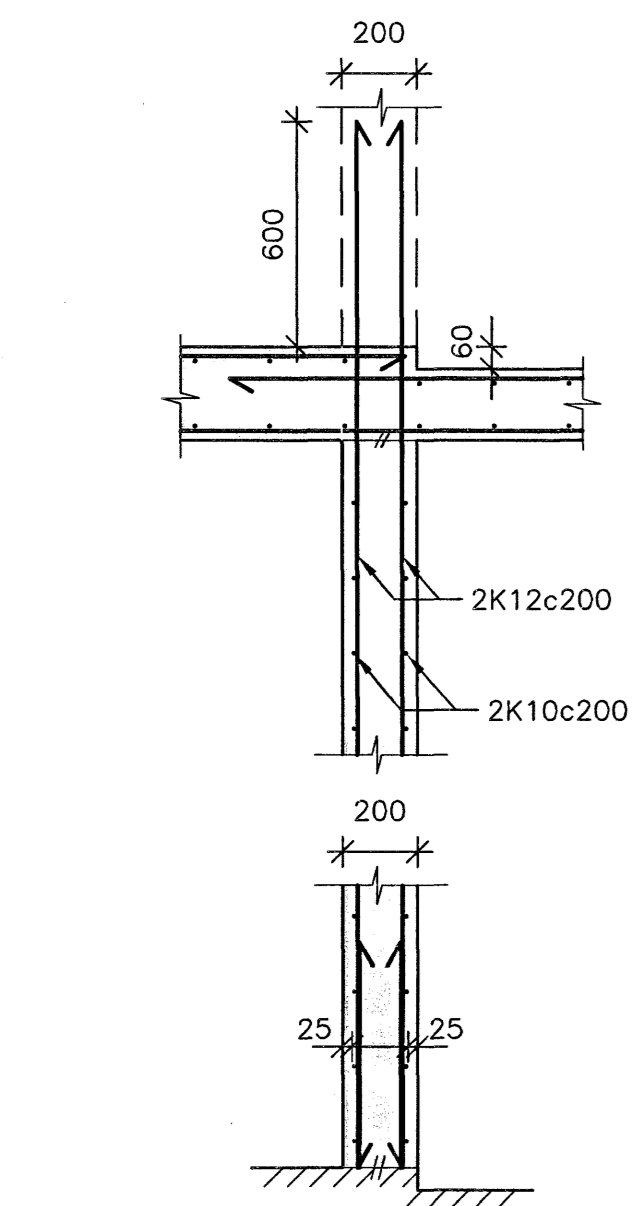
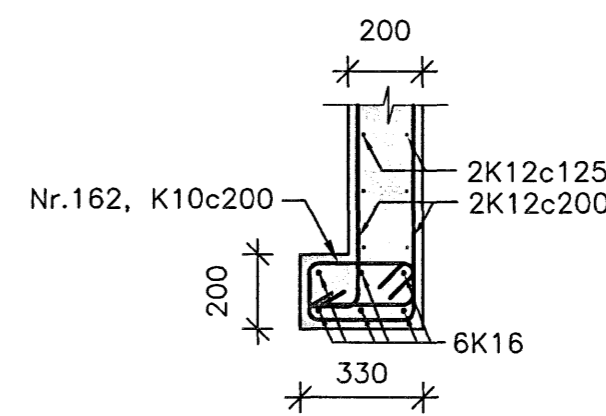

F SNID  
01-01 1:20

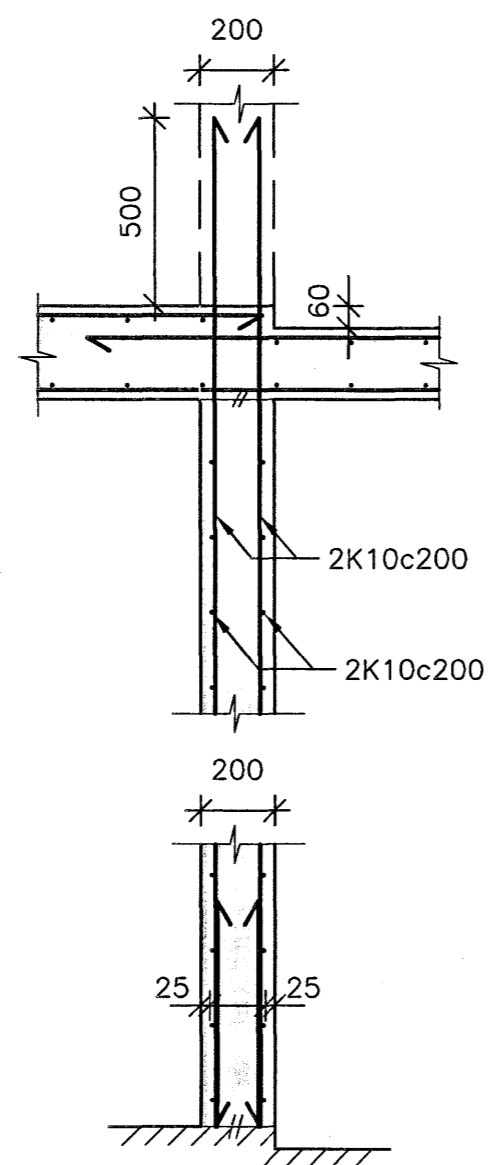

G SNID  
02-01 1:20

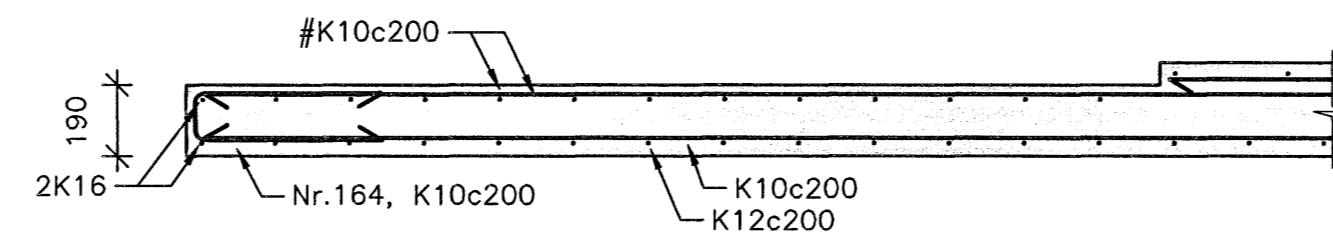

I SNID  
01-01 1:20

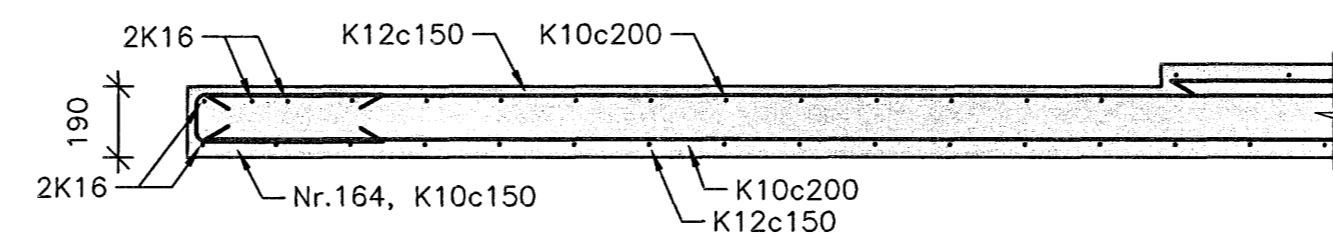

J SNID  
01-02 1:20

SKÝRINGAR:

Almennar skýringar sjá teikningu B-00-00, skýringarblað.

Járnaskrá sjá teikningu B-12-01.

Fágulistar úr stáli, skulu vera 2,5 mm bykkir úr svörtu stáli St.37-2. Listar skulu söðnir saman á samskeytum með >50 mm endaskörum, og festir rakilega í mótum fyrir steypu.



ÓTGÁFA	DAGSETNING	TEIKNAD	YFIRFARÐ	SAMÞYKKT
EDLI	BREYTINGAR			

Lykilmynd

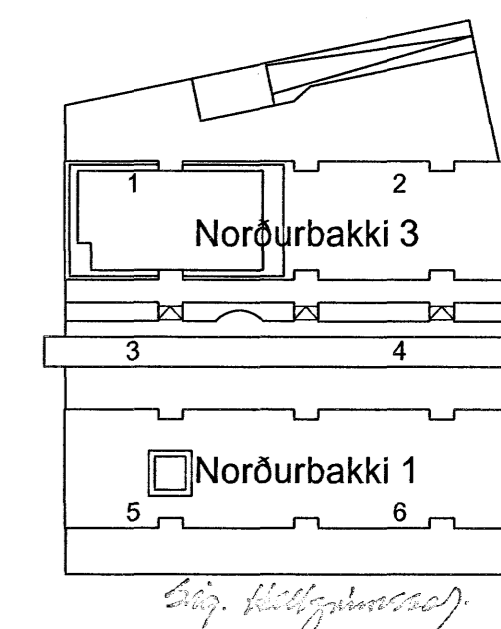

HANNAÐ:	S&J	DAGS.:	19.10.2006
TEIKNAD:	S&J/SI	KVARDI:	1:20
YFIRF.:	ÞeL	VERK NR.:	5275
SKRÁ:	b-11-01.dwg	TEIKN.NR.:	B-11-16
SAMB.:	090954-2459		

FRUMSTÆRÐ BLAÐS A1  
BLAÐSTÆRÐ A3, MINNKUN 1:2

Norðurbakki 1 og 3

Burðarvirki  
Snið



SUDURLANDSBRÁUT 4 108 REYKJAVÍK NETFANG: fjarhitun@fjarhitun.is  
SÍMI 578 4500 - FAK 578 4599 VEFSDÁ: www.fjarhitun.is  
KENNITALA 700186-1649