

Mkv.1:20
P1
B-04

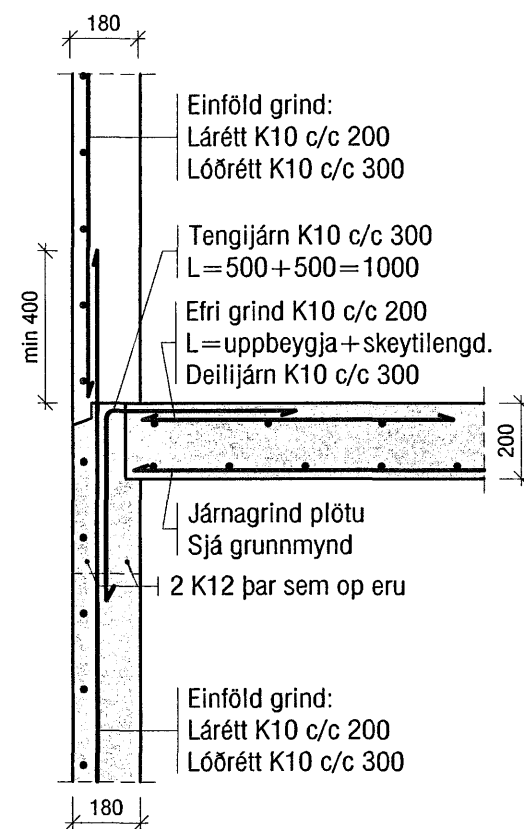

Mkv.1:20
P2
B-04

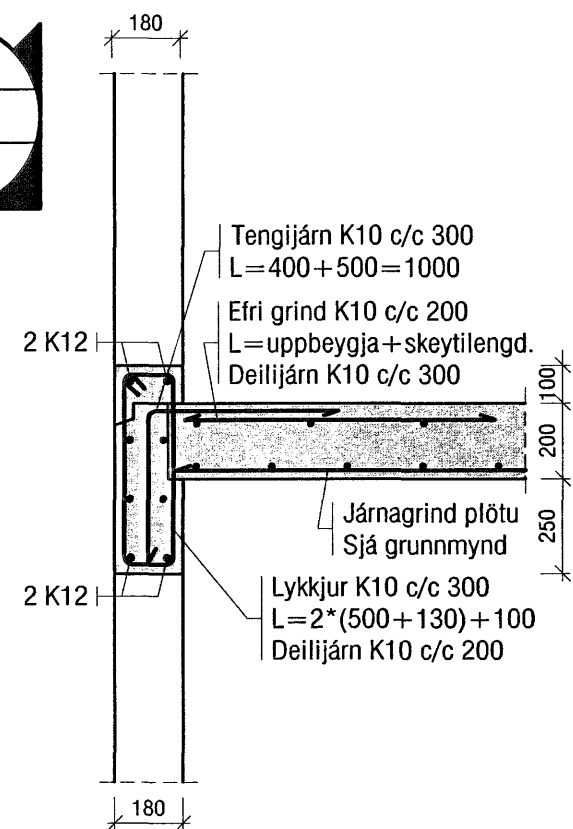

Mkv.1:20
P3
B-04

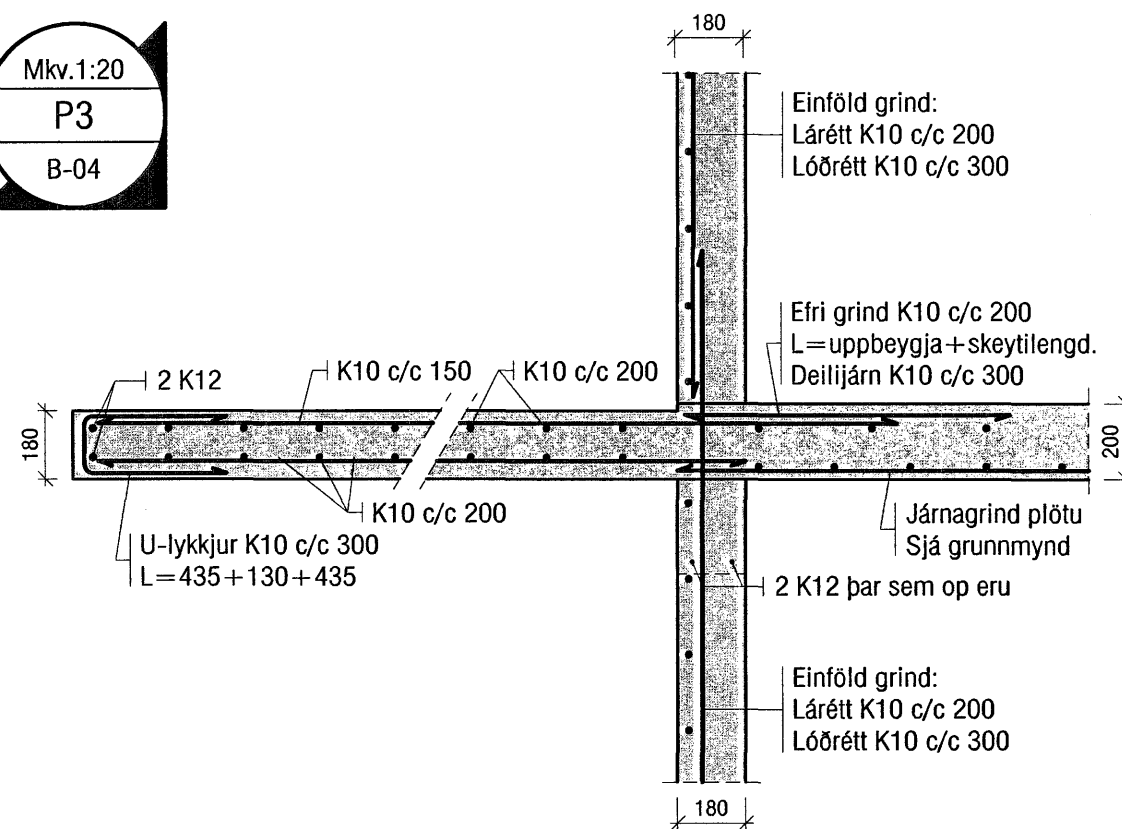

Mkv.1:20
P4
B-04

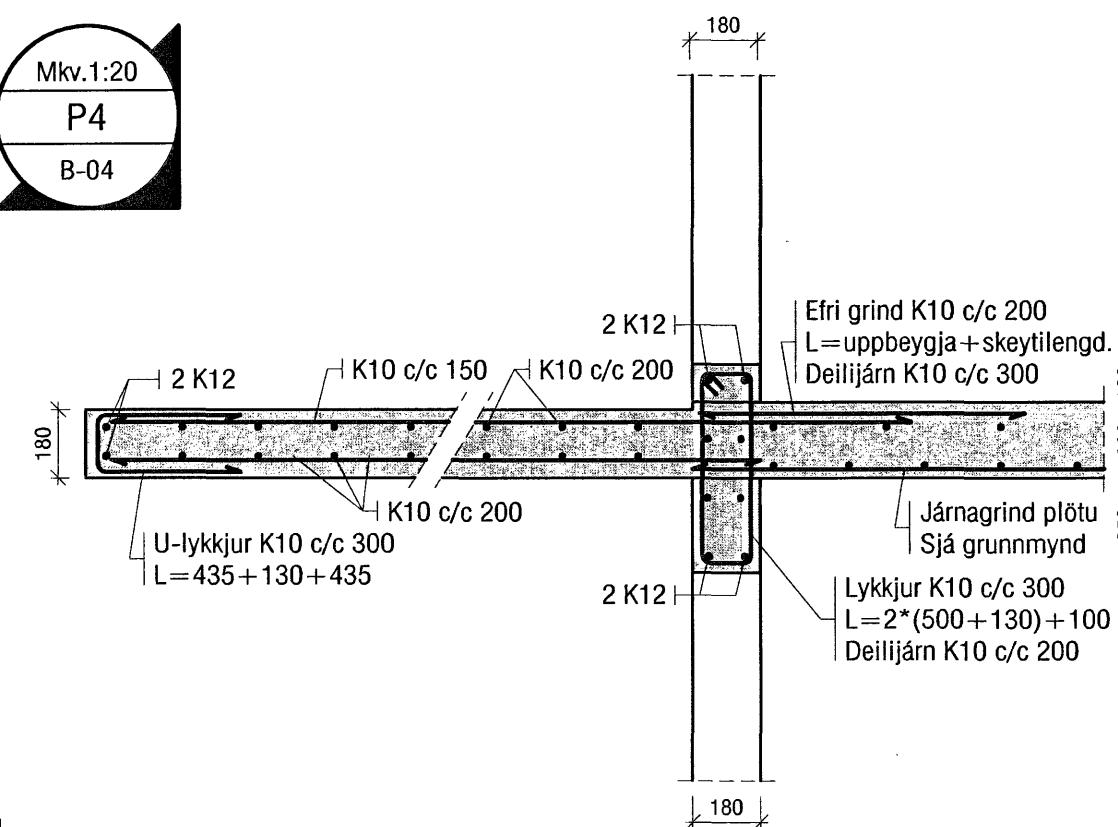

Mkv.1:20
P5
B-04

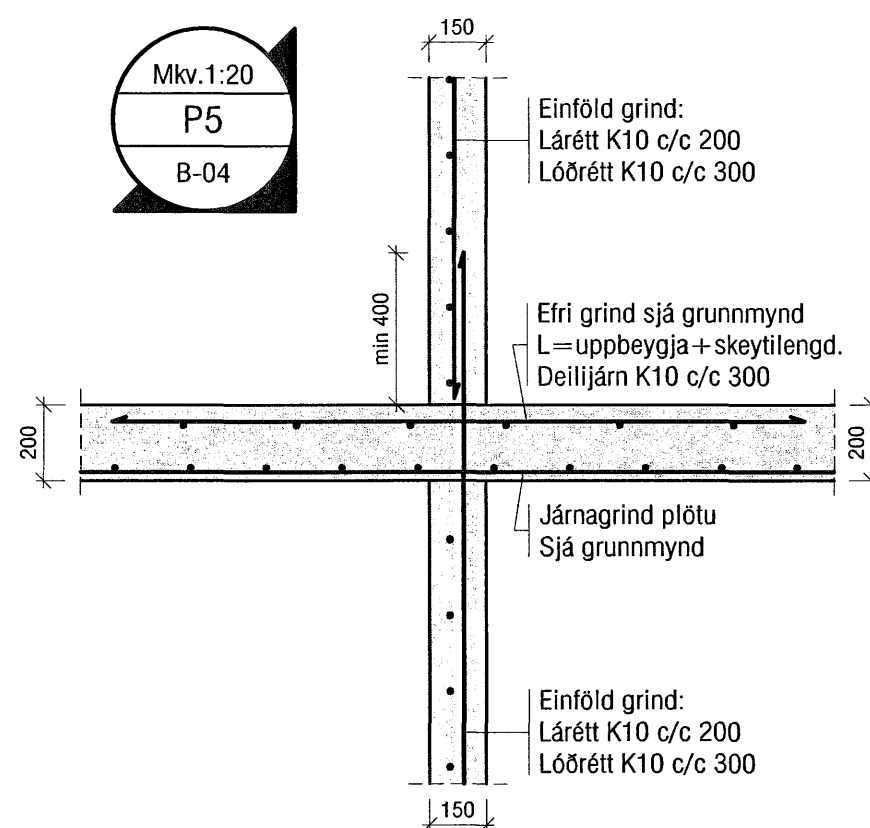

Mkv.1:20
P6
B-04

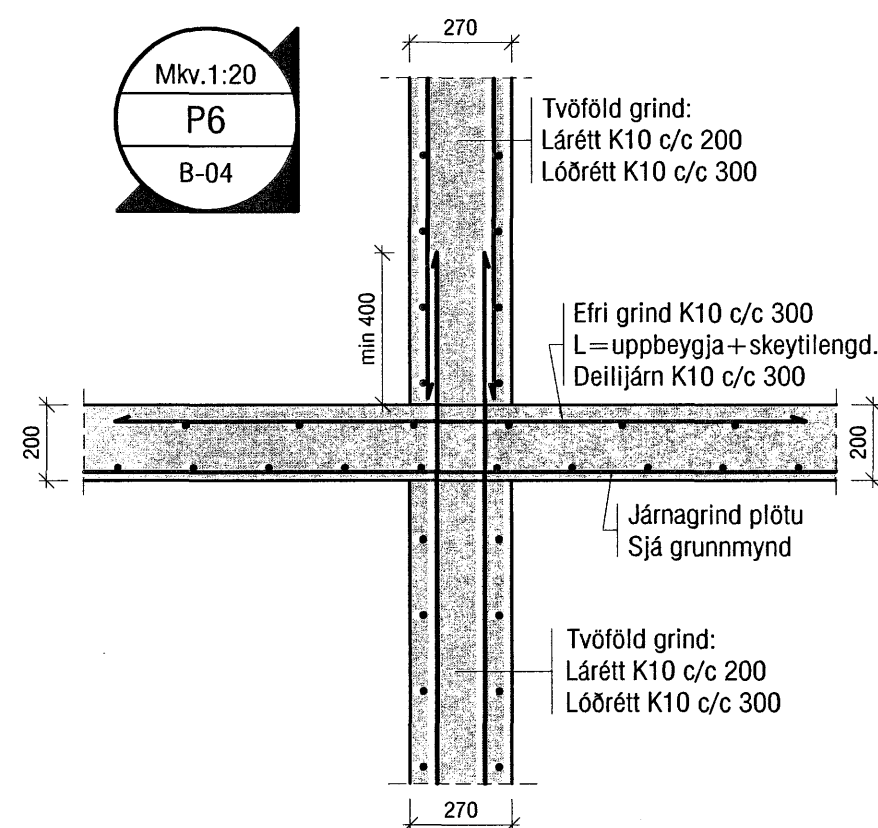

Mkv.1:20
P7
B-04

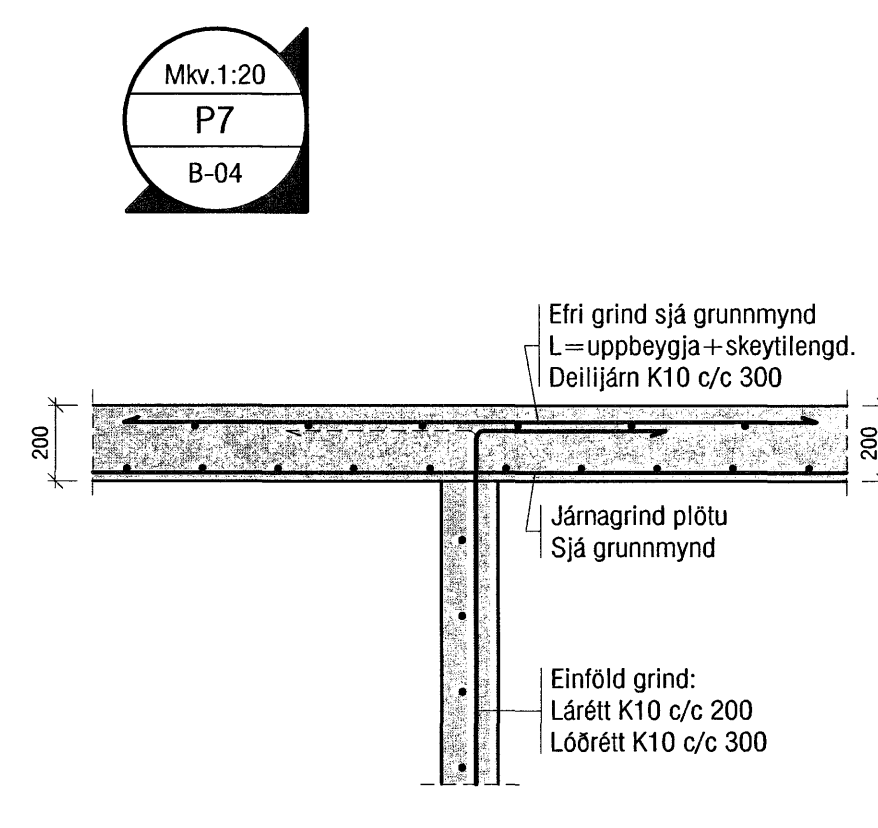

Mkv.1:20
P8
B-04

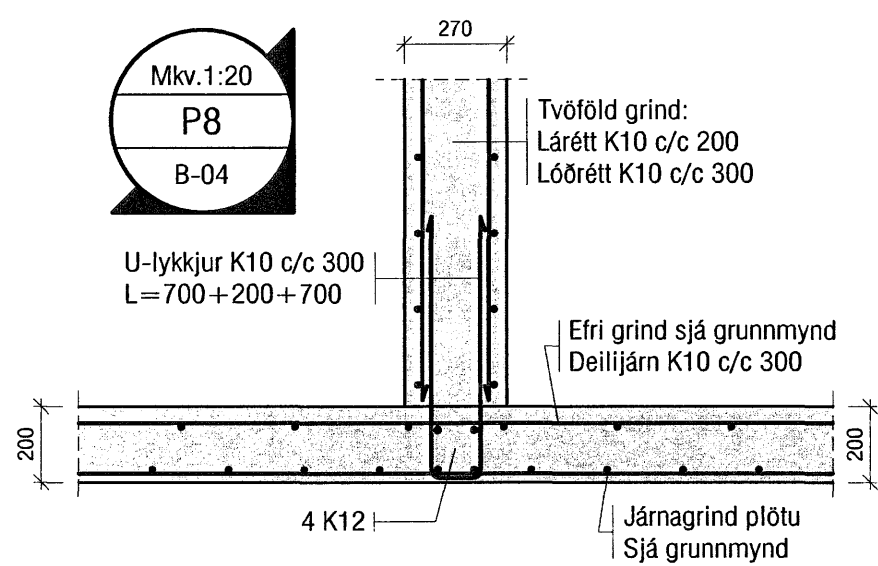

Mkv.1:20
P9
B-04

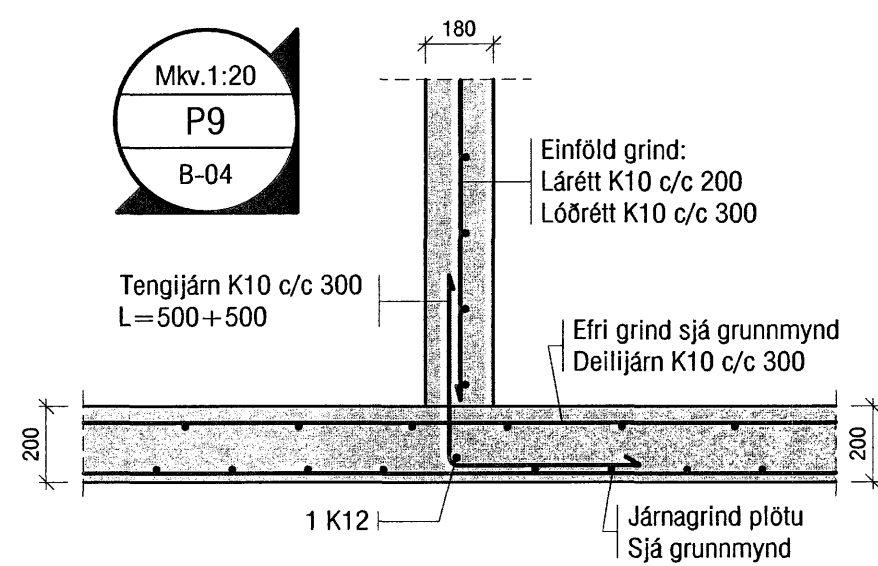

Samþykkt þann
17 JULI 2007

Byggingfulltrúinn í Hafnarfirði
F.h.Sigurbjartur Halldórsson

VEKTOR - hönnun og ráðgjöf - Akralind 6, 201 Kópavogi.		Sigurður Hafsteinsson byggingatekniþráðingur Kt. 030693-7749 sími: 554-8650 fax: 554-6669.		GLITVELLIR 2, HAFNARFIRÐI	
		Teikn. nr. Tilkvæmt á teikningu Samþykkt		Br. Dags.	
Teiknað Hannað Dagsetning 09.07.07		Teiknað PJ Verk nr. A-07-05-22		Teiknað PJ Mælikvarði 1:20 Teikn. nr. B-05	