

Samþykkt þann
05 FEB. 2008
 Byggingarfulltrúinn í Hafnarfirði
 F.h. Hrölfur S. Gunnlaugsson

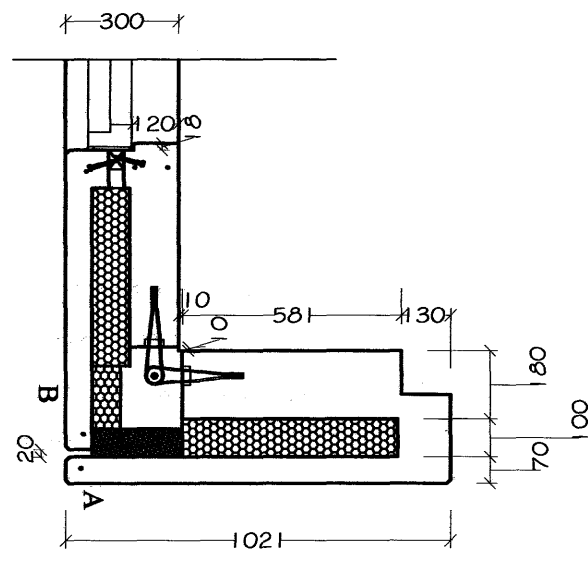

Snið E2 1:20

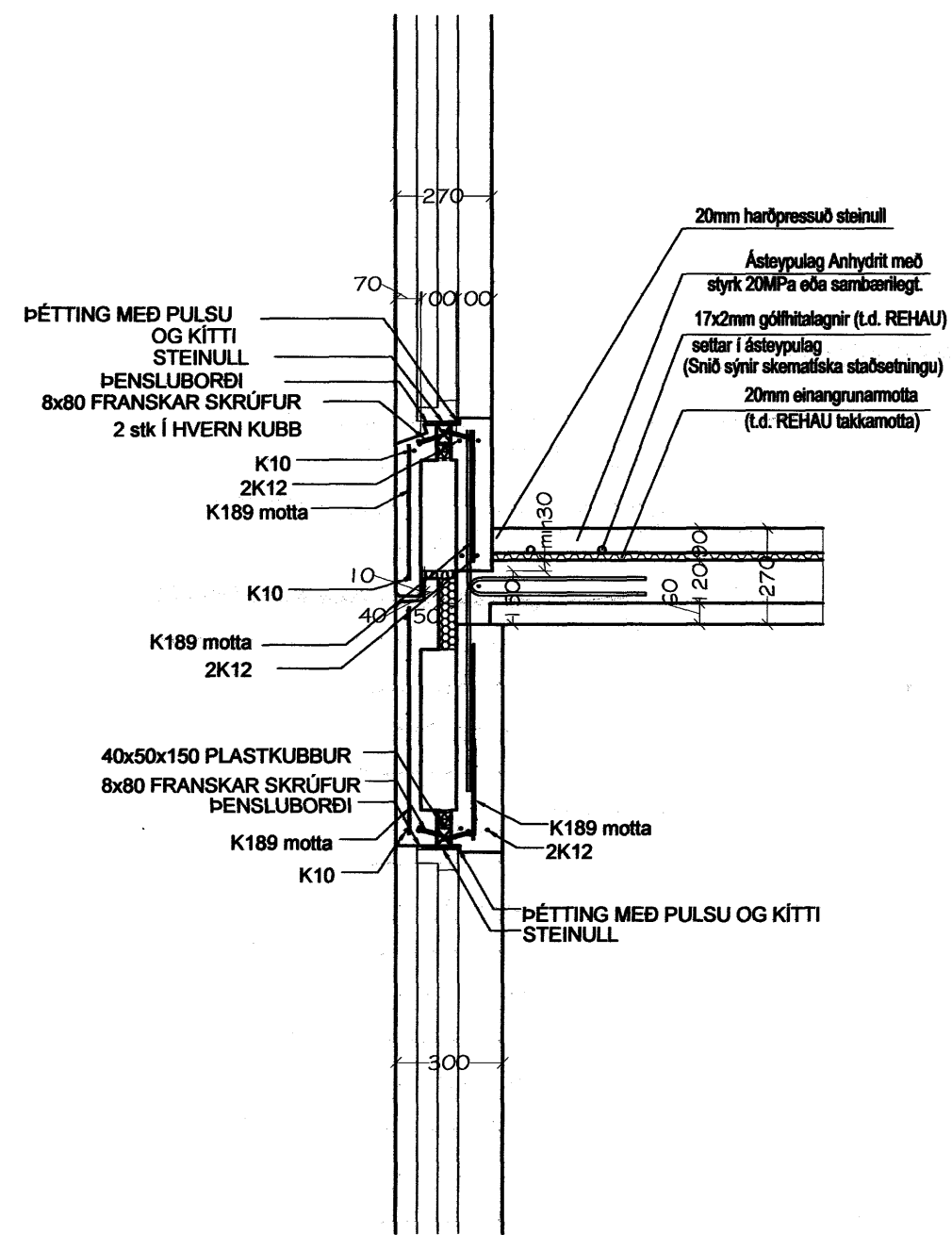
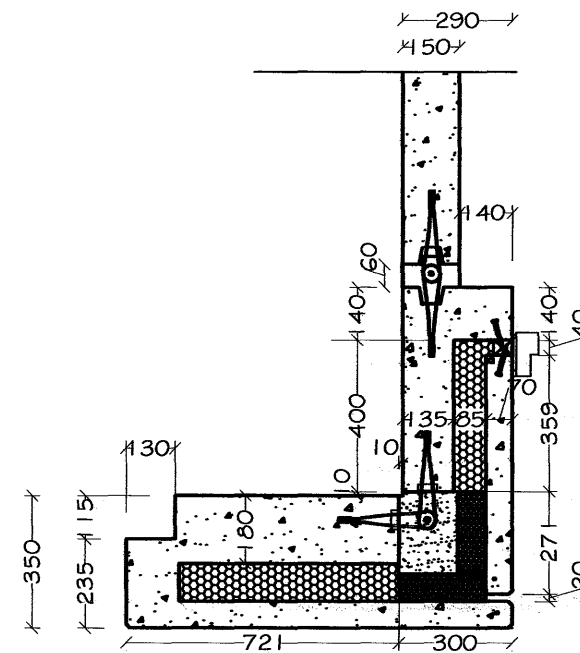

Snið E3 1:20

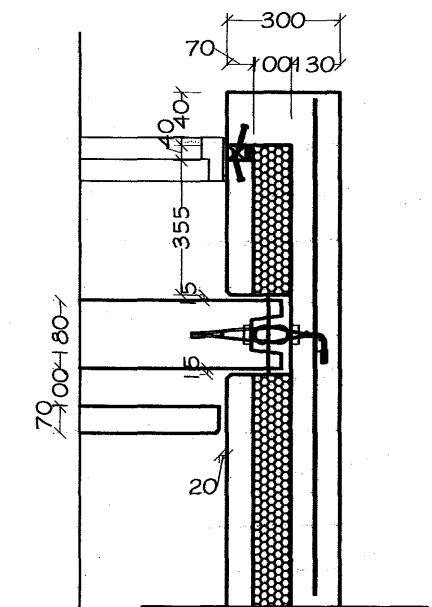

Snið E12 1:20

Snið E6 1:20

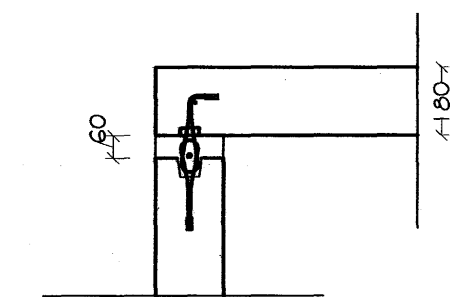
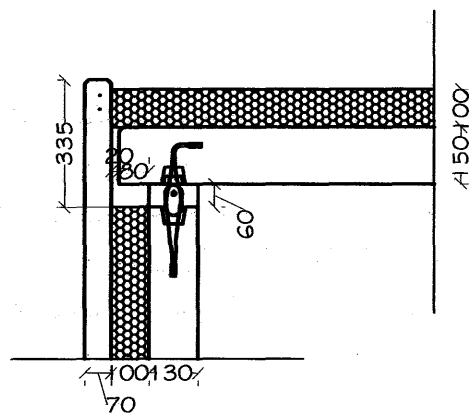

Snið E5 1:20

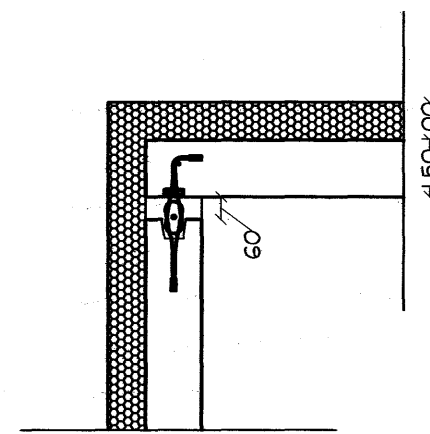

Snið E8 1:20

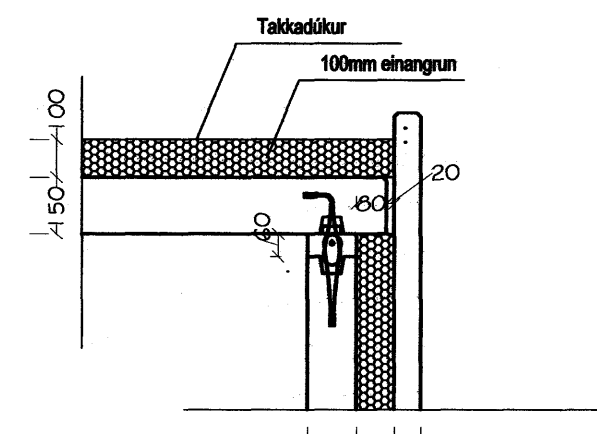

Snið E10 1:20

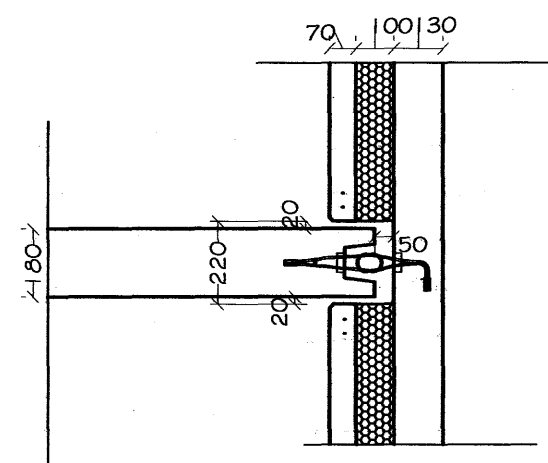

Snið E4 1:20

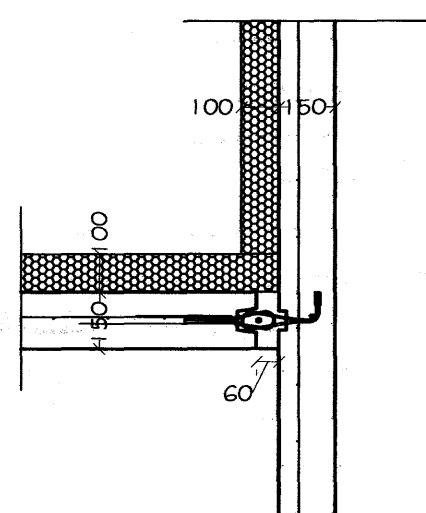

Snið E7 1:20

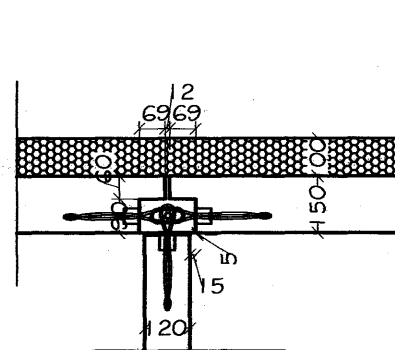

Snið E9 1:20

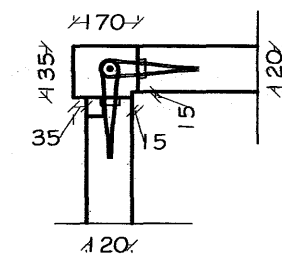

Snið E11 1:20

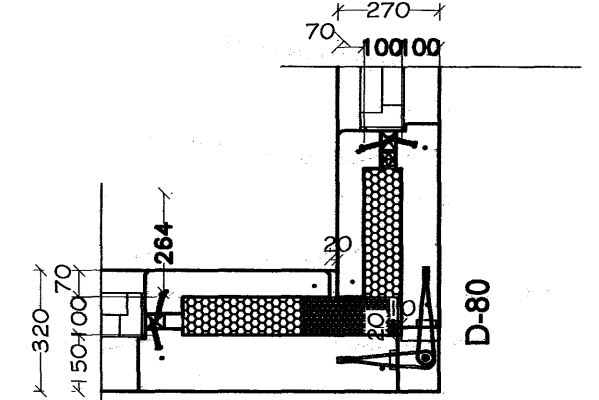

E-180
 Snið E13 1:20

Hrölfur S. Gunnlaugsson
 Áritun aðalhönnuðar skv. gr. 19.2 byggingarreglugerð (samræming séruppdráttá)

Breytingar			Fjólúas 38, Hafnarfjörður	
Nr.	Dags.	Wah		
			Björgir Guðmundsson Byggingartæknifræðingur kt. 040562-3629	
			Klukubergí 11 s. 564-5146	
			221 Hafnarfjörður Netfang: bjorgir@tgverk.is	
			Deili	Nr. 15B
				Dags. 21.11.07
			Lögg. hönnuður: Þjarni Árnason kt. 290461-4489	

Þjarni Árnason