

01
BH/2 SNID 1:10

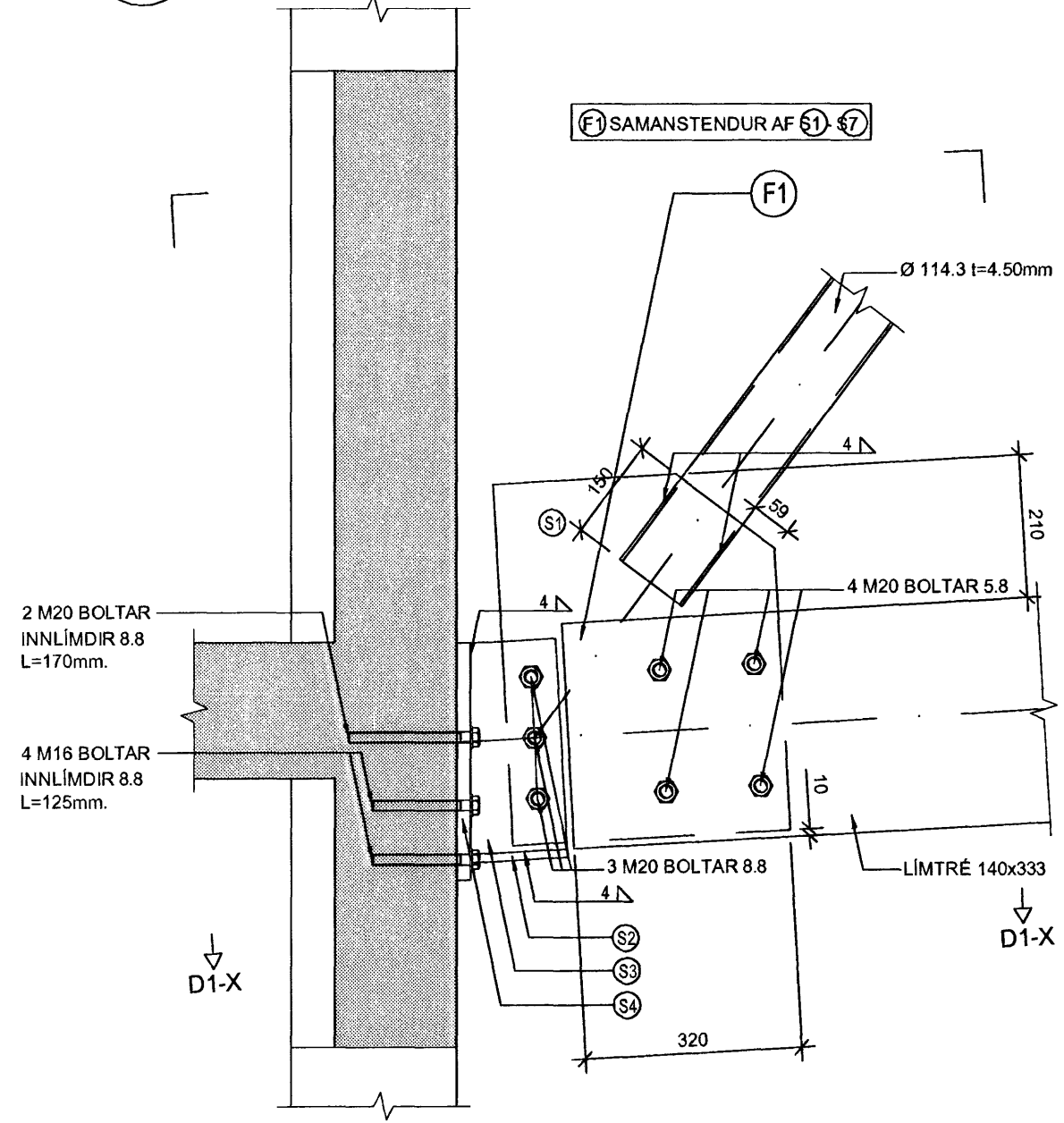

D1-X
BH/4 SNID 1:10

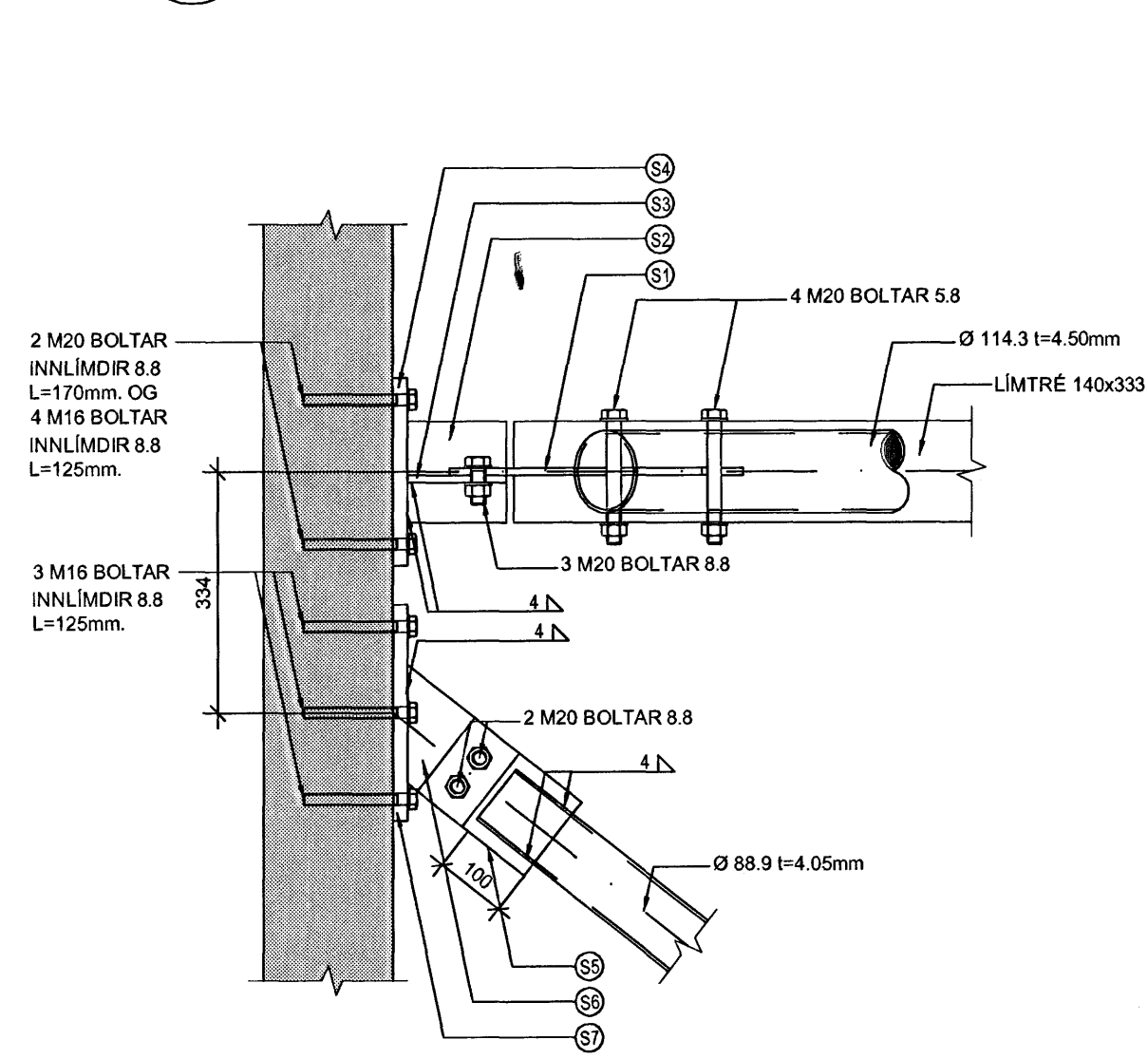

02
BH/2 SNID 1:10

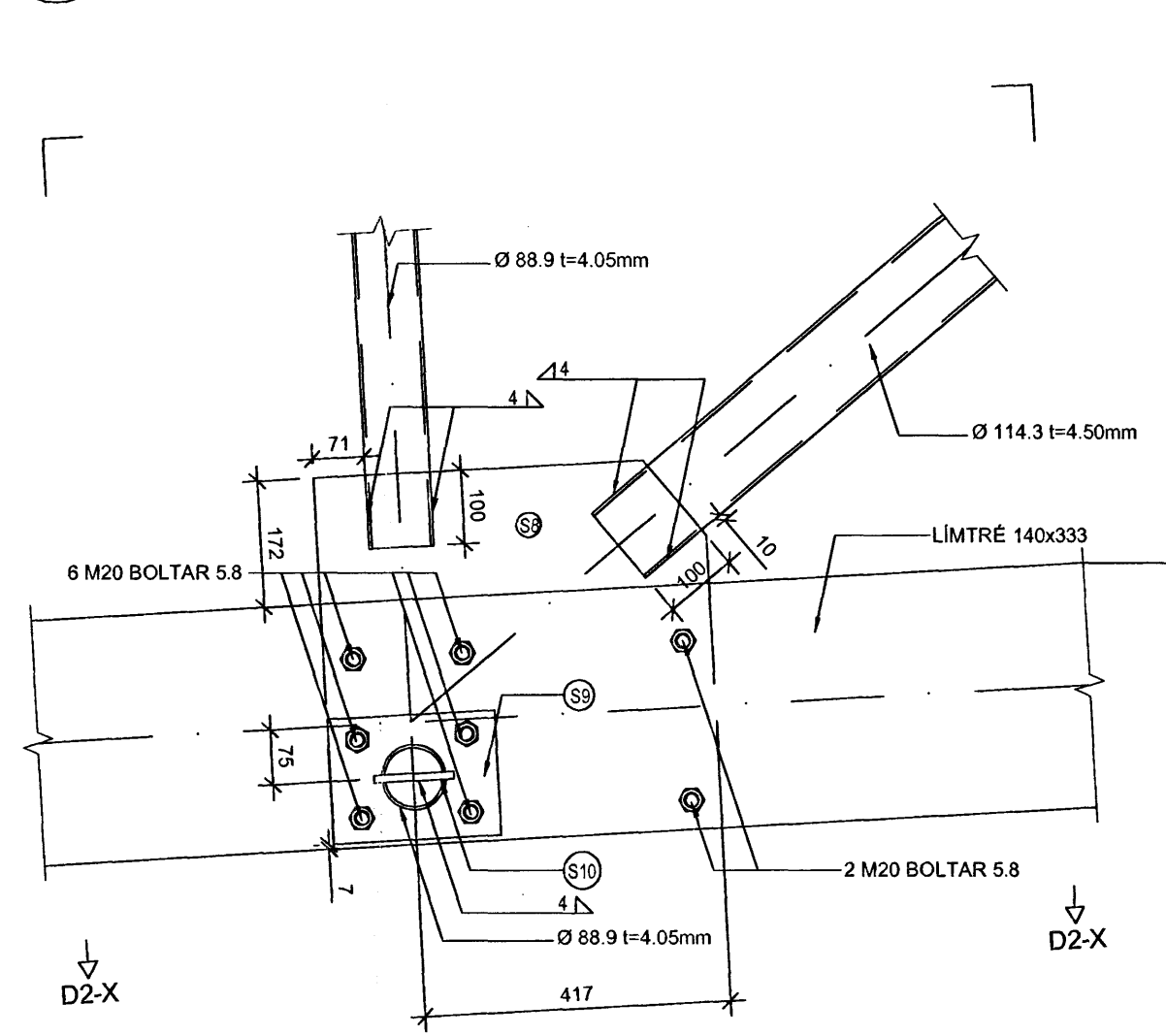

D2-X
BH/4 SNID 1:10

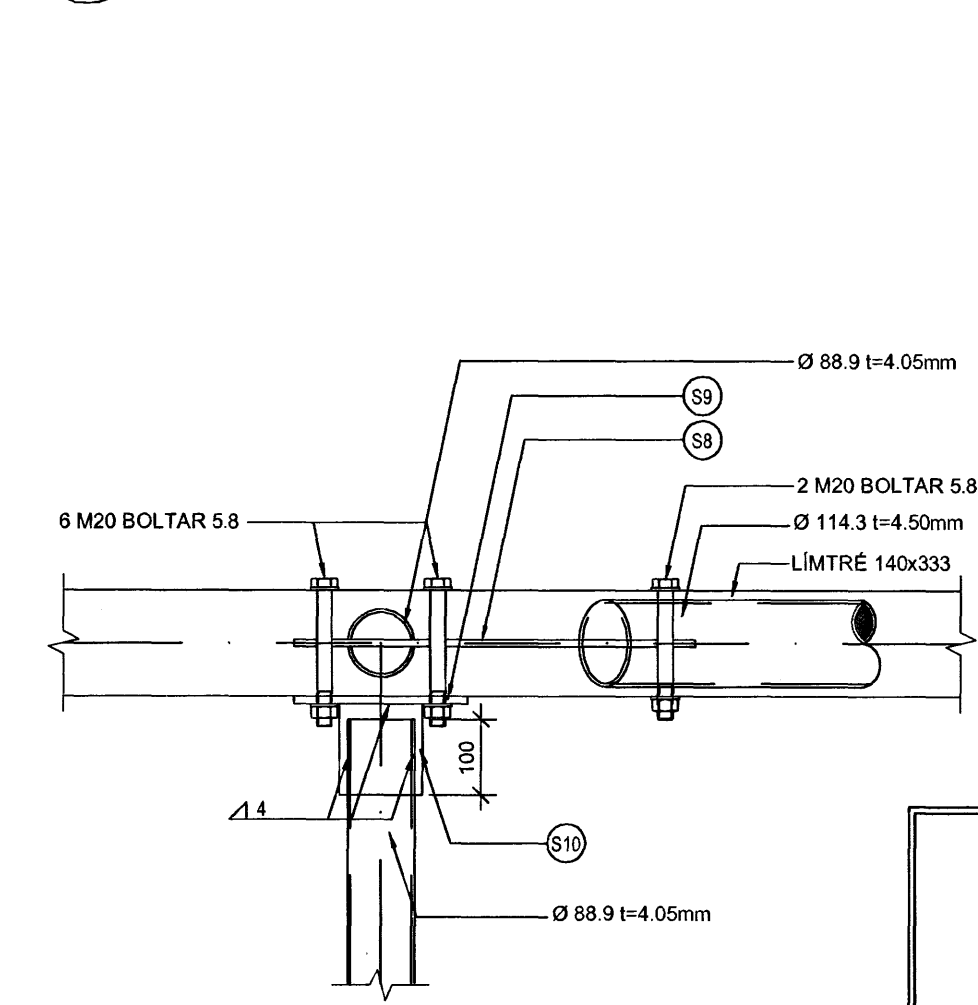

ATH
MÁLSETNINGAR OG KÓTAR:
ÁÐUR EN SMÍÐI HEFST SKAL SANNREYNA ÖLL MÁL OG KÓTA Á BYGGINGARSTAD.
SAMLESA SKAL ÖLL MÁL OG ÚTSETNINGAR Á ARKITEKTATEIKNINGUM VÍÐ NÚVERANDI BYGGINGAR.
SJÁ GATAPLAN FYRIR ÚTÓK Í STEYPU.

ALMENNAR SKÝRINGAR:
ÖLL MÁL ERU Í mm OG ALLIR KÓTAR ERU Í m.

03
BH/2 SNID 1:10

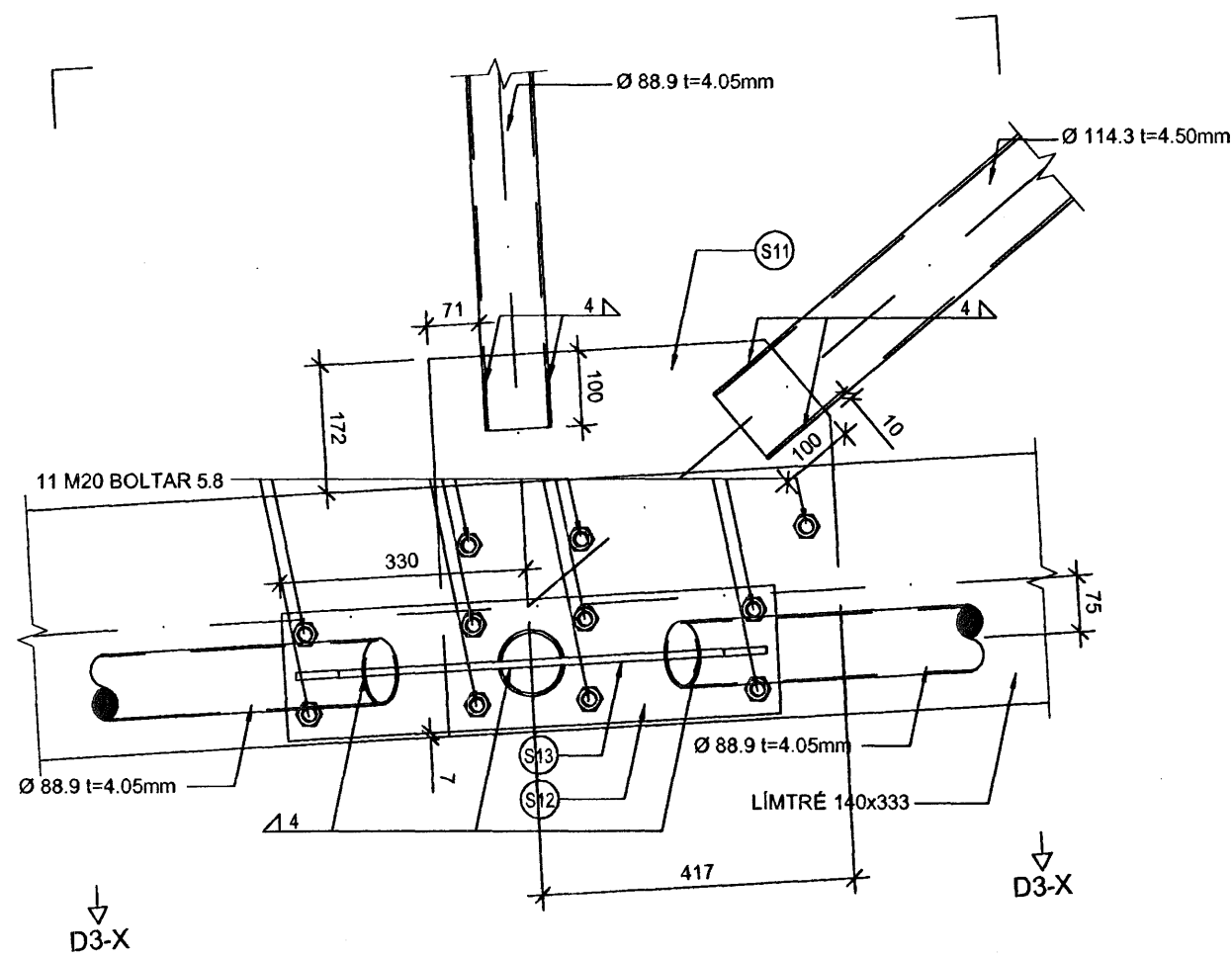

D3-X
BH/4 SNID 1:10

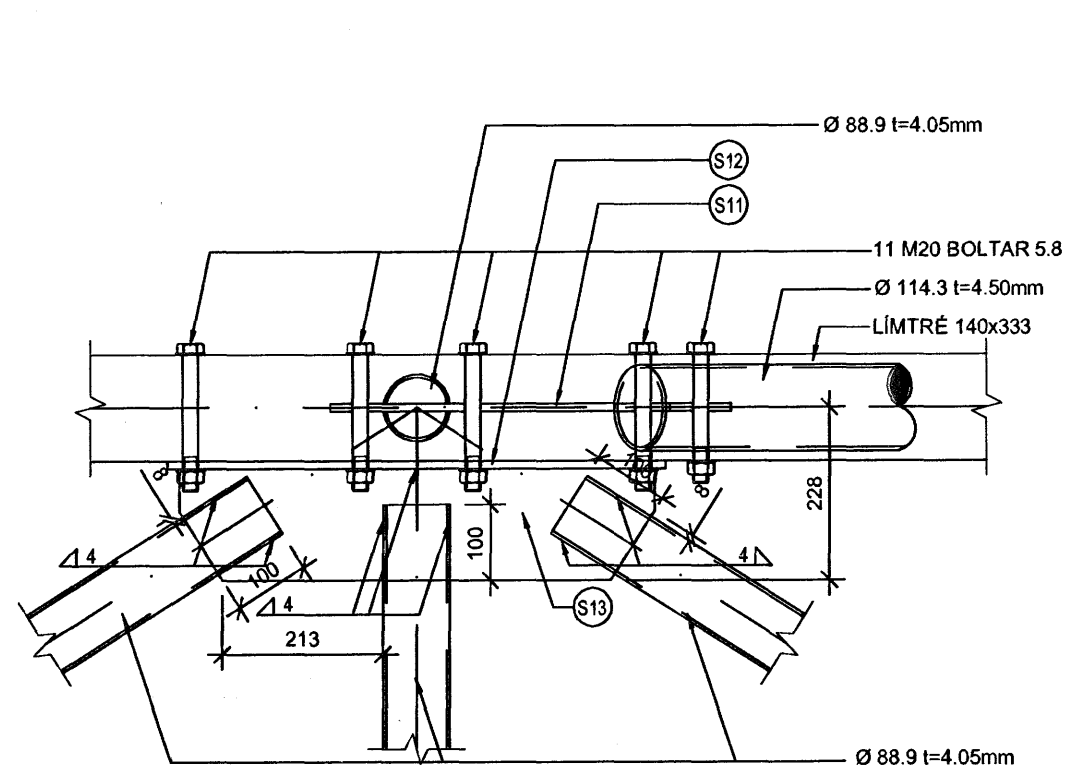

04
BH/2 SNID 1:10

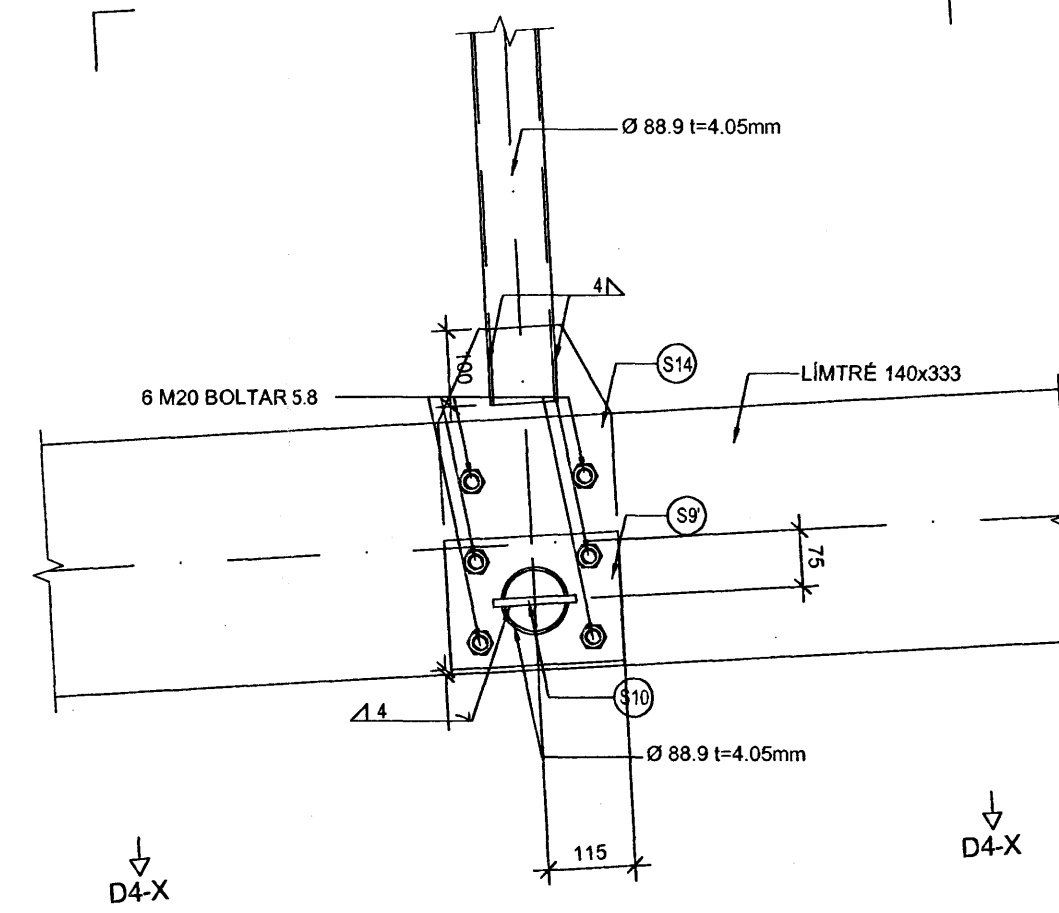

D4-X
BH/4 SNID 1:10

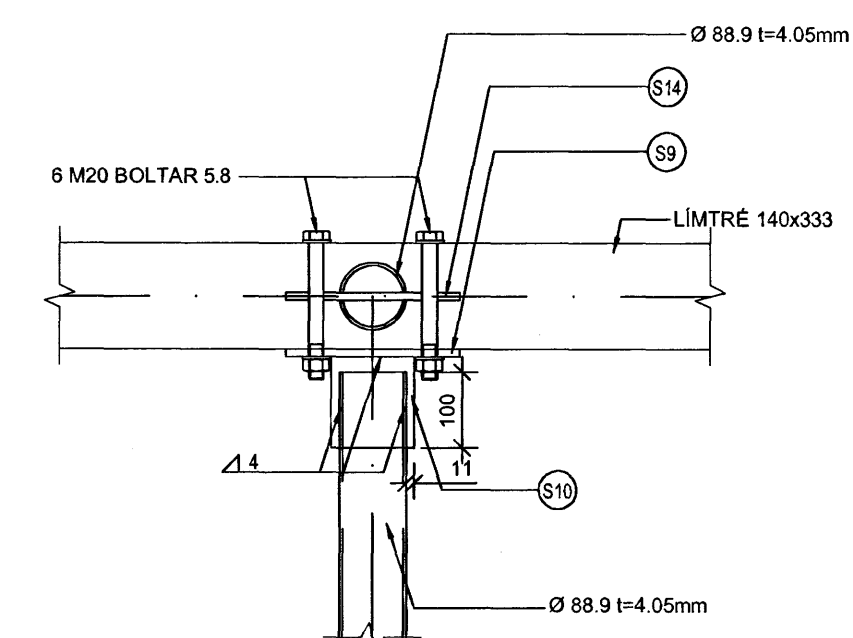

Þessi teikning er byggd á 02/25/08-7579
TILVÍSANIR:
ALMENNAR SKÝRINGAR B-A-01
SNID OG DEILI B-SD-01-06
MÁLSETNINGAR PLATA B-SD-07-08
HLIDARMYNDIR B-H-01-02
TEIKNINGAR ARKITEKTA
TEIKNINGAR LAGNAHÖNNUDA
TEIKNINGAR RAFMAGNHÖNNUDA

A	02.02.2006	BOLTASTÆRUM BREYTT OG FJARLEGDUR BREYTT	BK	BK
BR.	DAGS	BREYTING	REKN.	TEKN.

05
BH/2 SNID 1:10

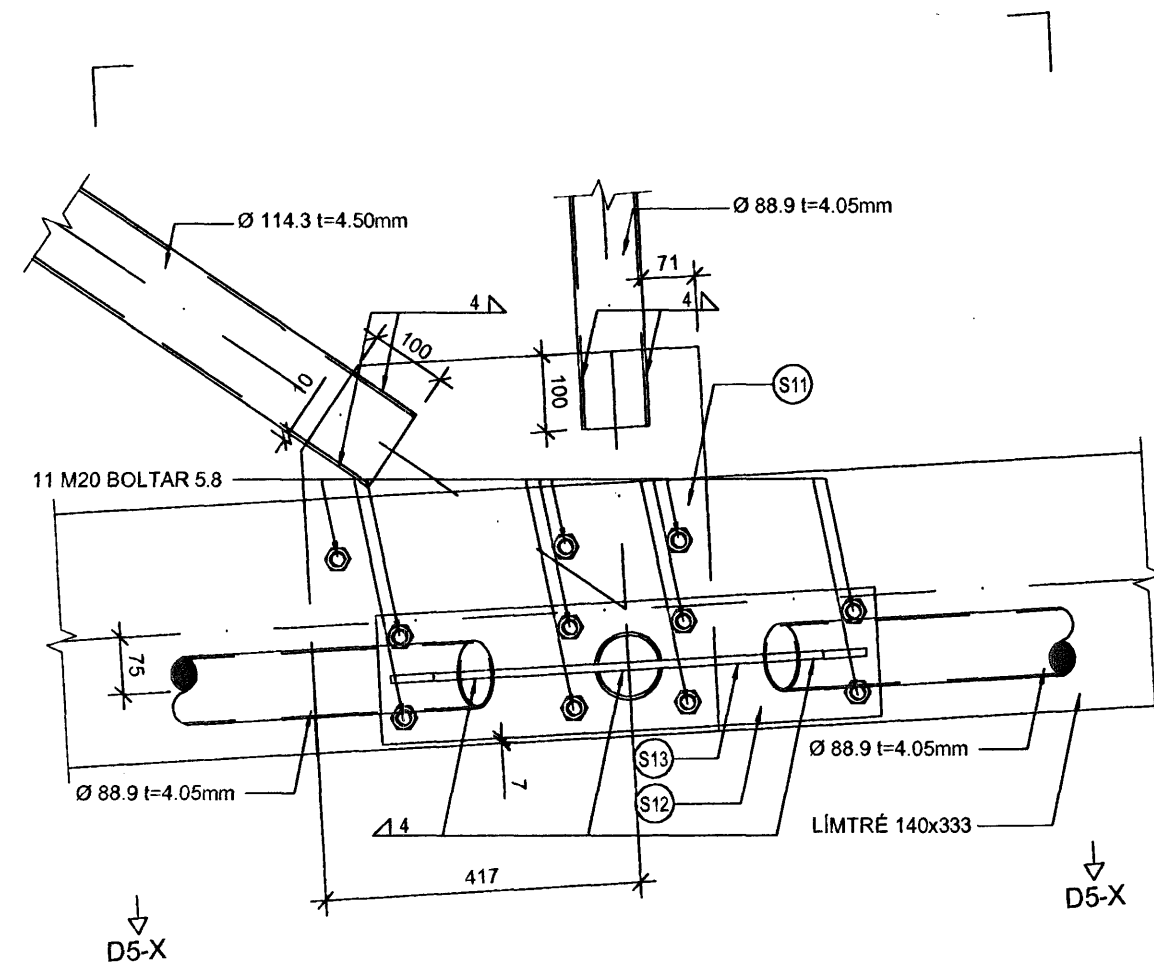

D5-X
BH/4 SNID 1:10

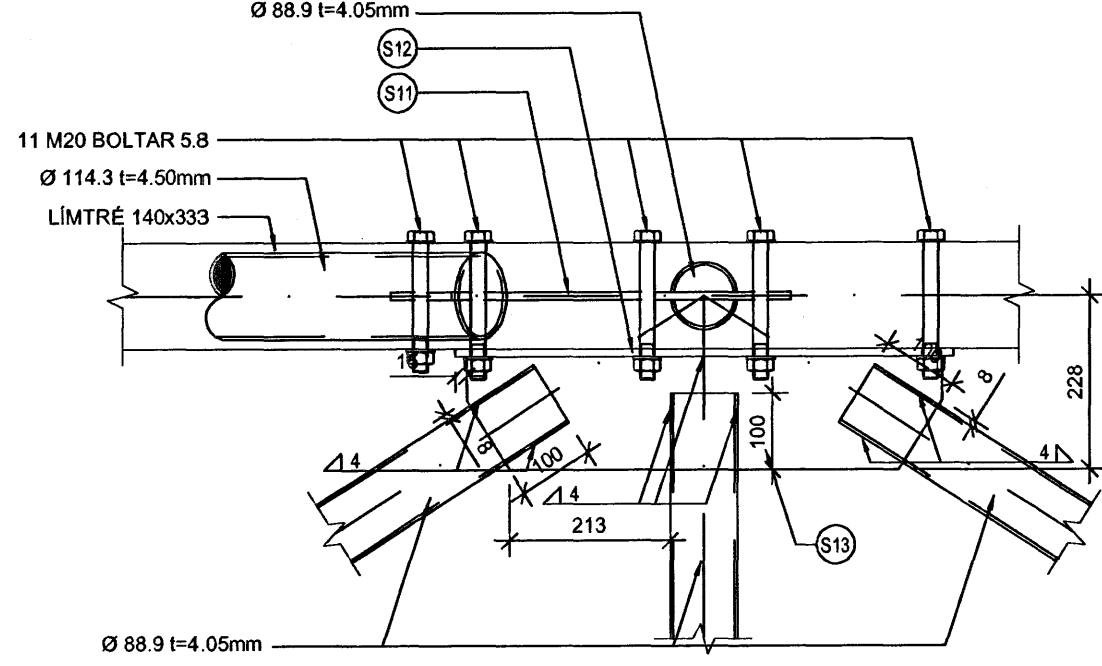

06
BH/2 SNID 1:10

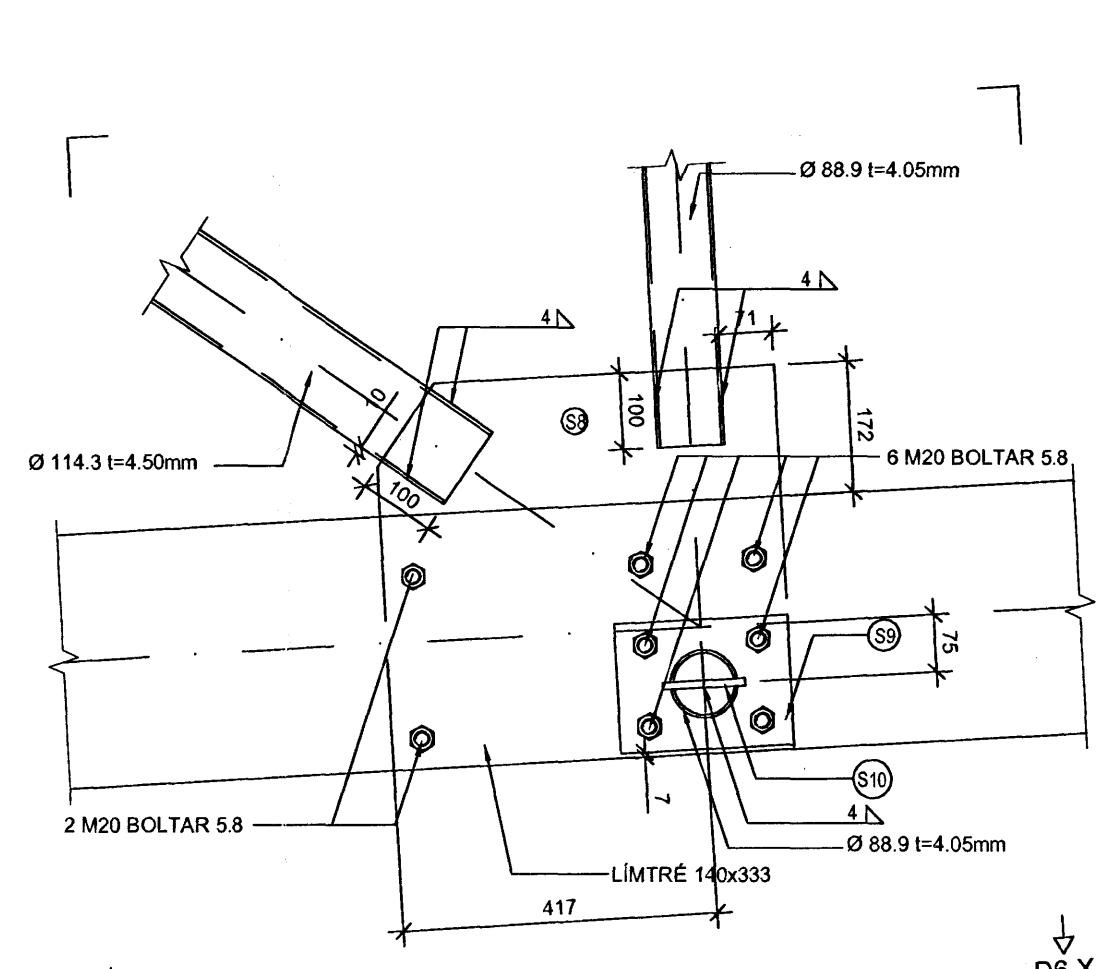

D6-X
BH/4 SNID 1:10

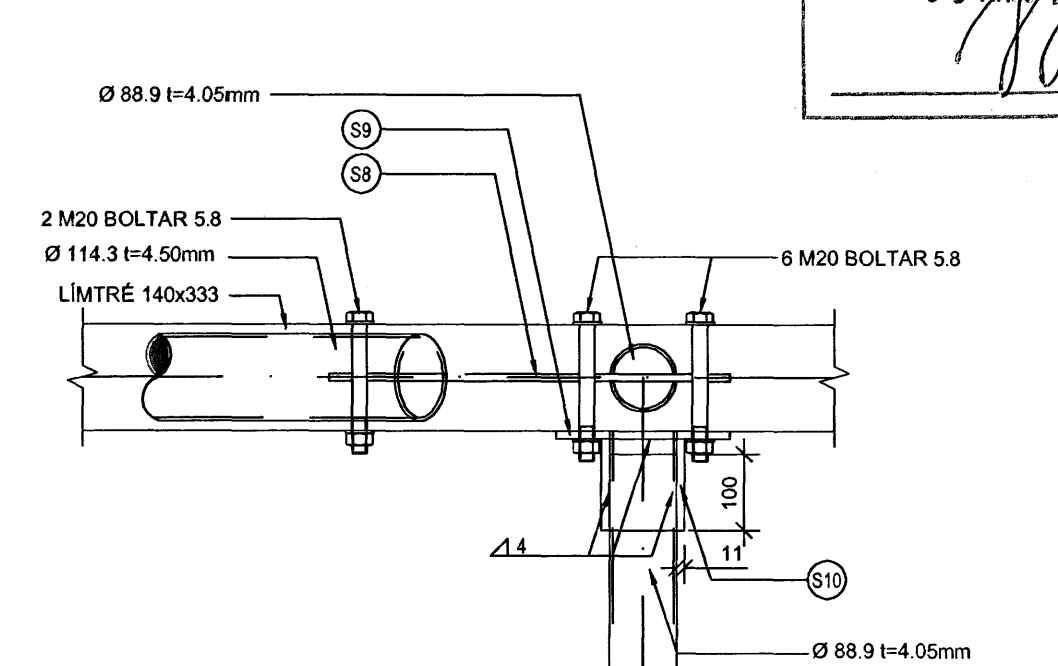

Þessi teikning er byggd á 05/11/2006

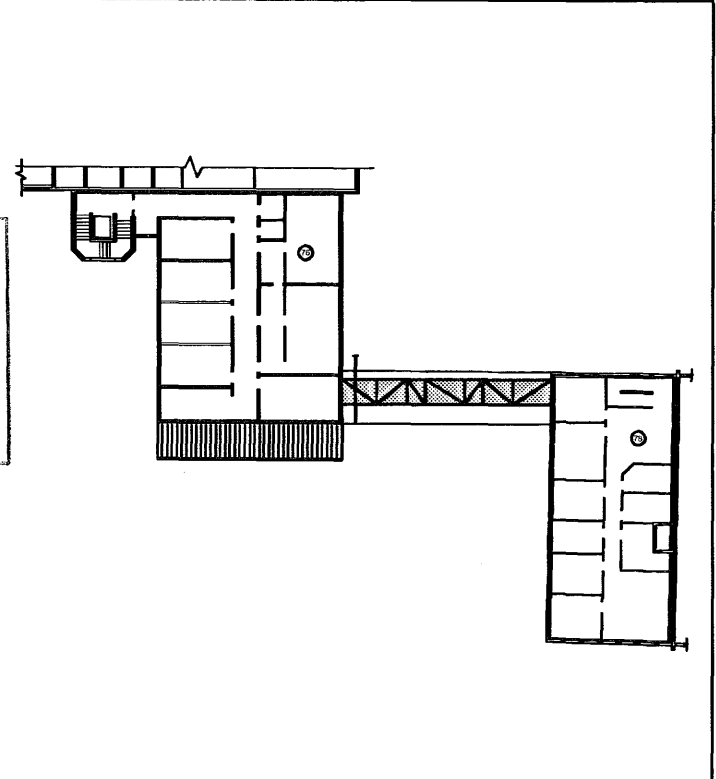

VSÓ RÁÐGJÖF

BORGARTÓN 24, 105 REYKJAVÍK, Sími 595-9000, Símafaxi 595-9010, NETTfangi vs@vs.is

REYKJAVÍKURVEGUR 76-78, HAFNARFJ.
ACTAVIS - TENGIBRÚ

BURÐARVIRKI
SNID OG DEILI

SKYRSLA
SÁBÞYKKT
KT.
24/07/2006

SKYRSLA
TEKNI. NR.
REYKJAVÍK
02.02.2006
BR.

05285 B-SD-01 A