

Mkv. 1:20
P1
B08/B09

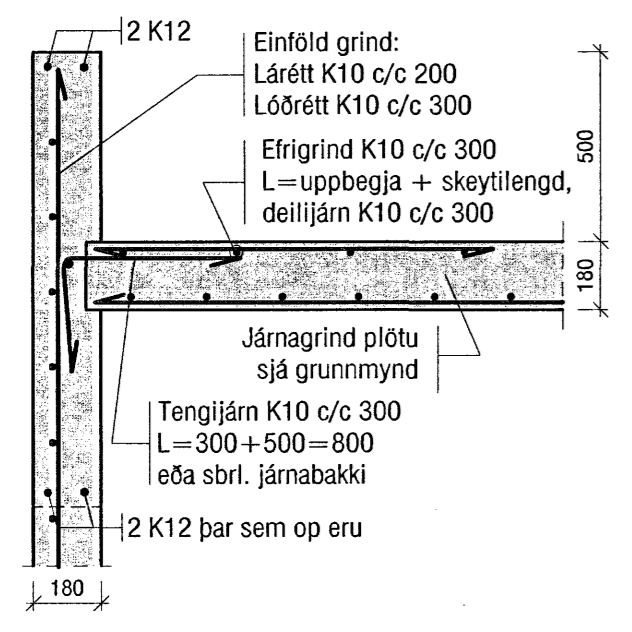

Mkv. 1:20
P2
B08/B09

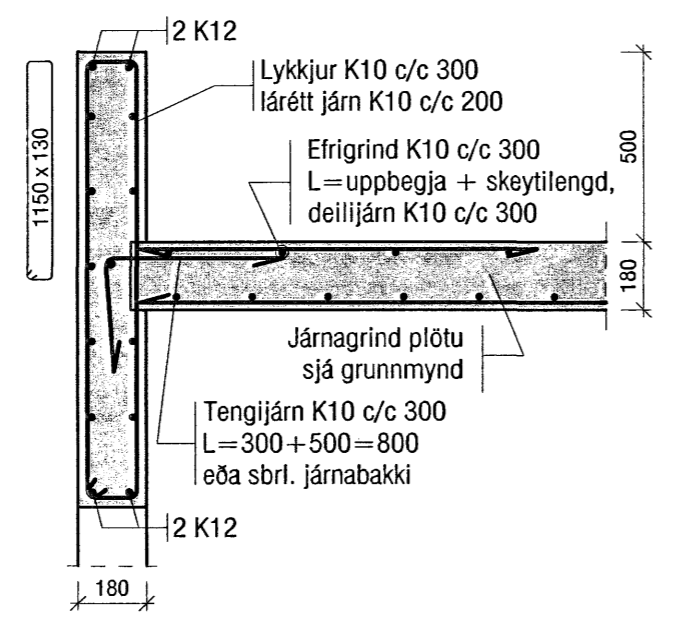

Mkv. 1:20
P3
B08/B09

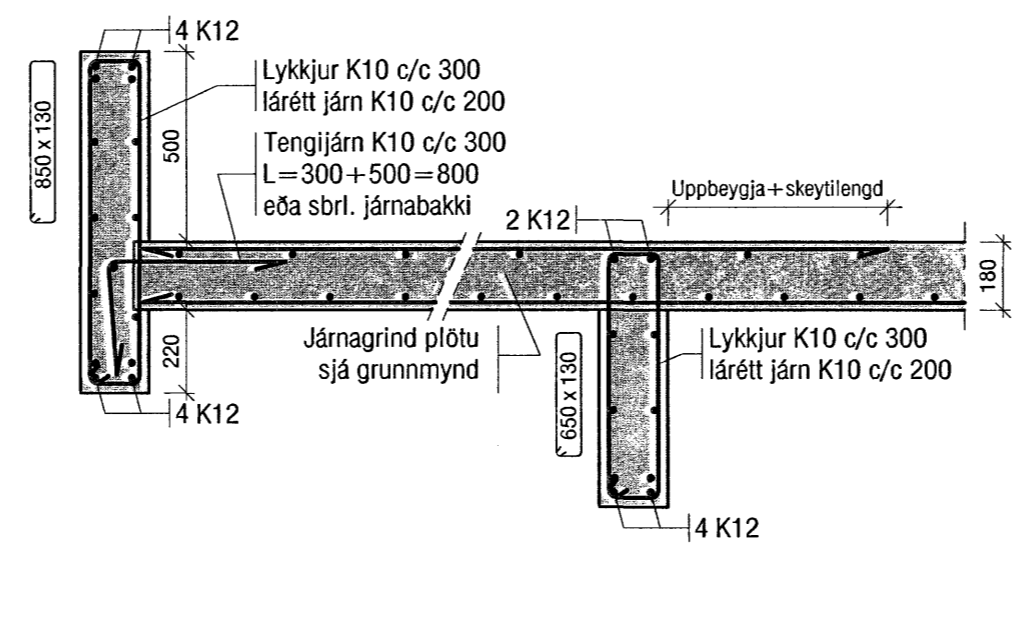

Mkv. 1:20
P4
B08/B09

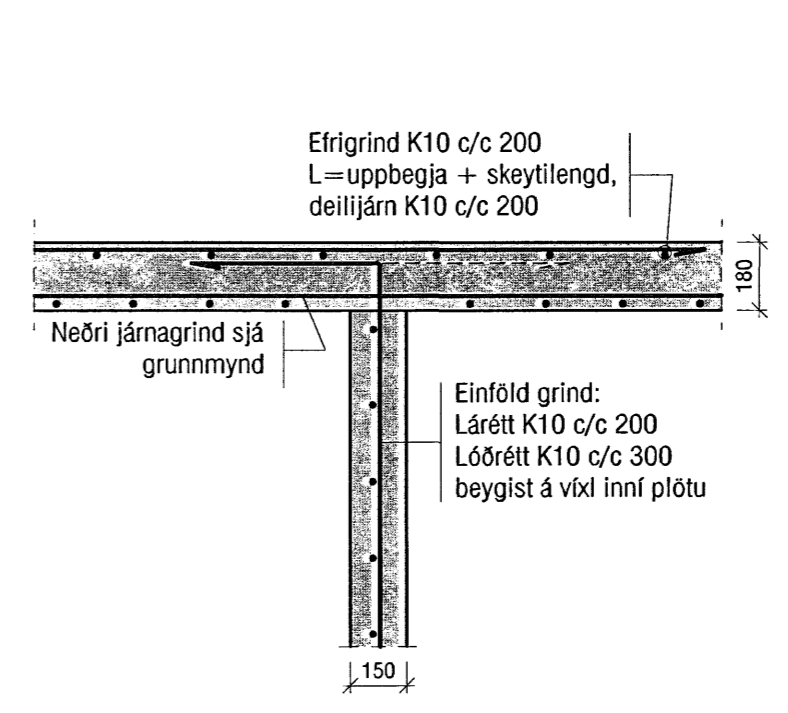

Samþykkt þáttur
20 JULI 2007
Byggingafulltrúinn í Hafnarfirði
F.h. Sigurbjartur Halldórsson

Mkv. 1:20
P5
B08/B09

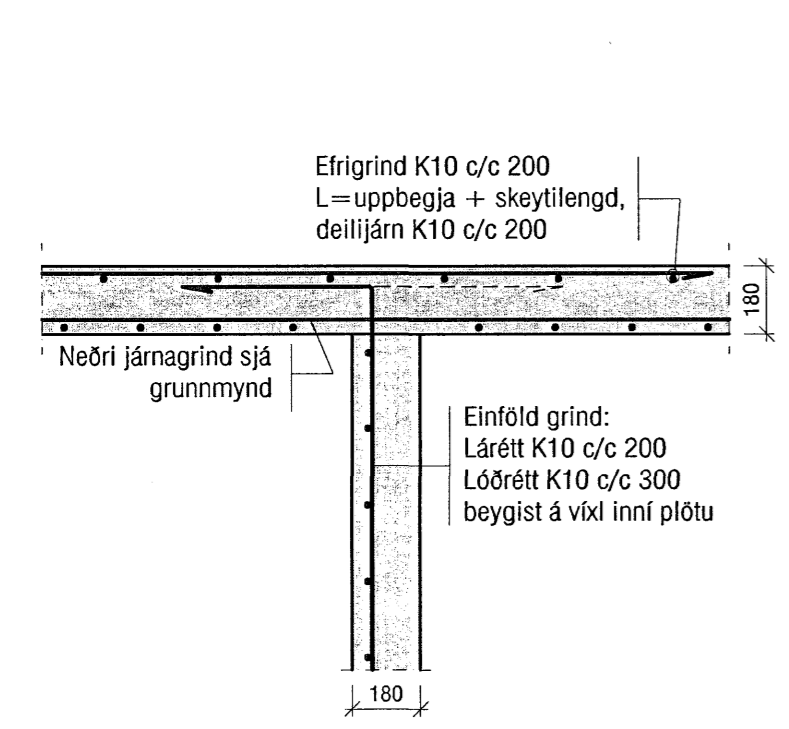

Mkv. 1:20
P6
B08/B09

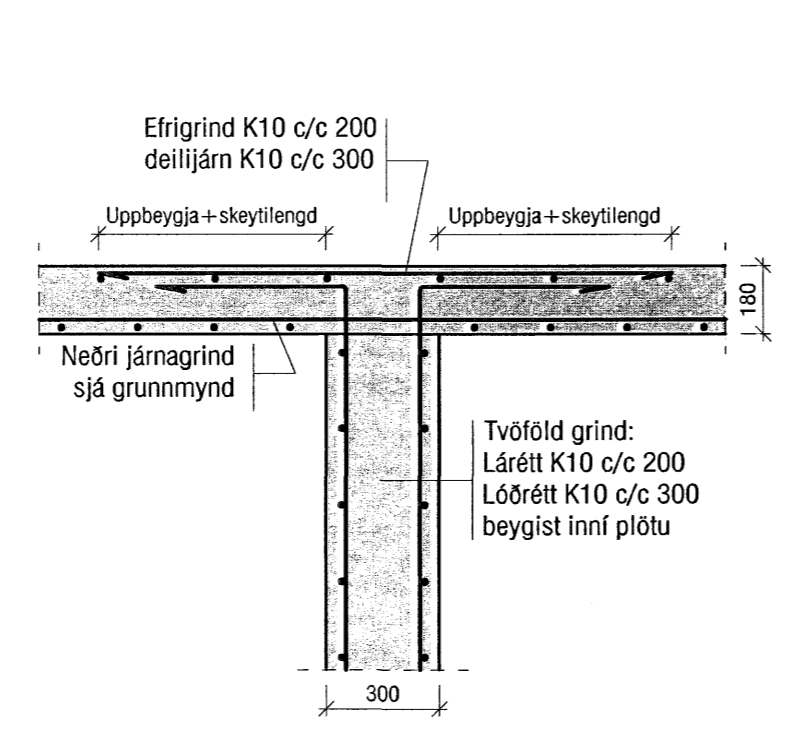

Mkv. 1:20
P7
B08/B09

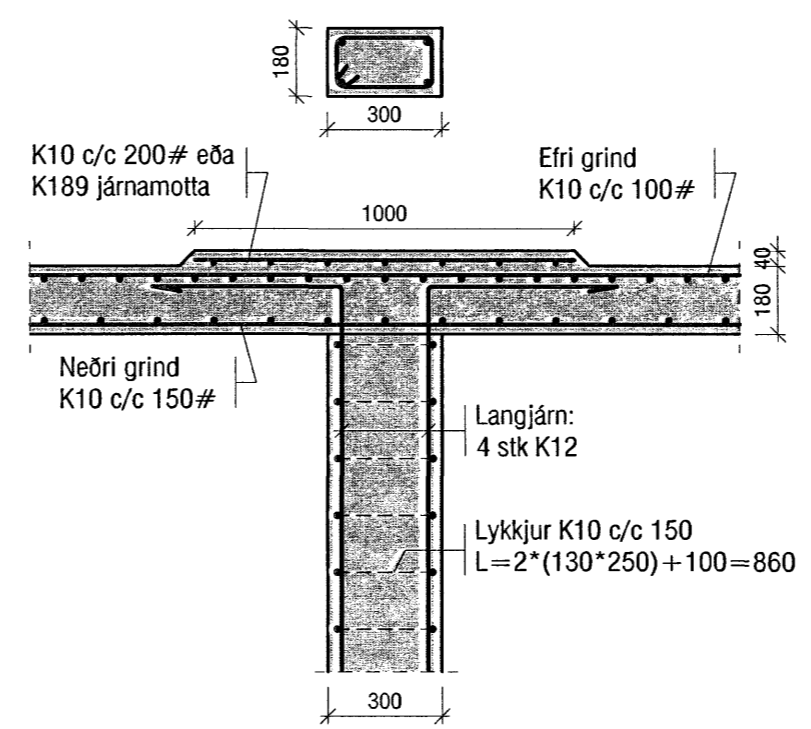

Mkv. 1:20
P8
B08/B09

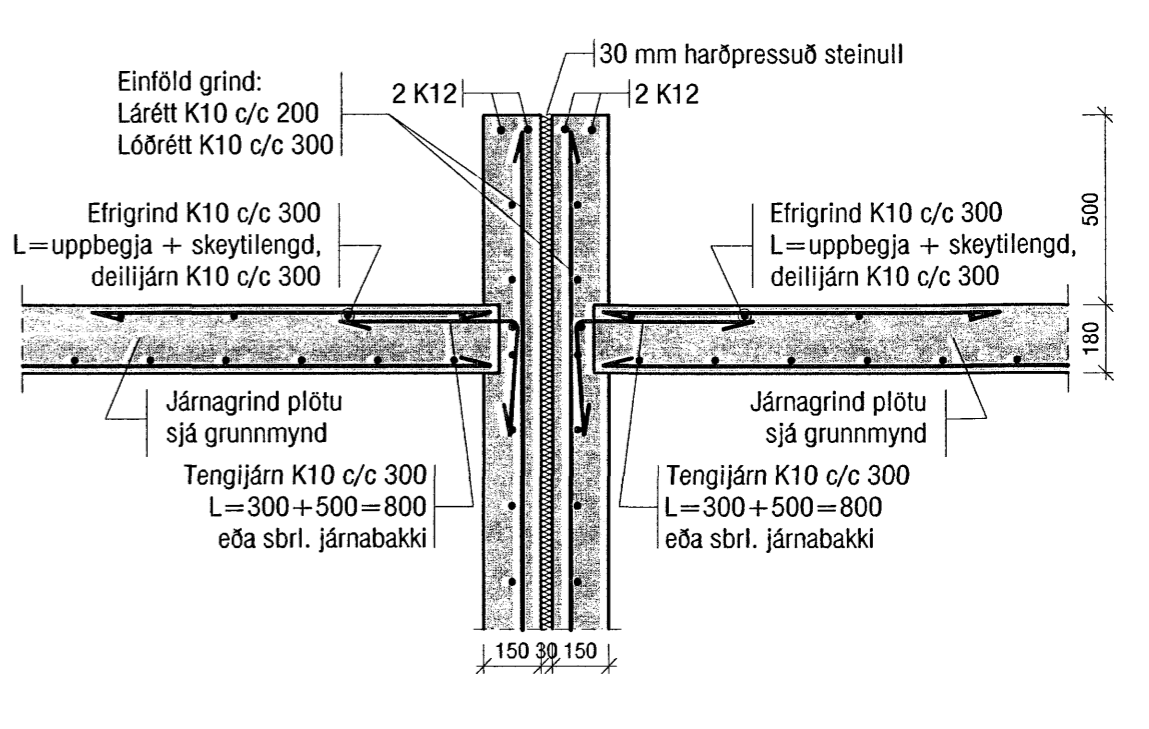

Skýringar:
Á teikningu B-01 eru almennar skýringar og öll lágmarks ákvæði varðandi steypu og bendistál t.d. frágangur á jörnum kringum op og brúnir og fl.
Allar stærðir skal sannreyna á byggingarstað áður en vinna hefst.
Ómerkt járn á deilum eru K10 nema annað sé tekið fram.

VEKTOR - hönnun og ráðgjöf - Nybýlavegi 6, 200 Kópavogi.		Sigurður Hafsteinsson byggingateknifráeðingur Kt. 030859-7749 sími: 554-0650 fax: 554-0669.	
Teikn. nr.	Tilvisun á teikningu	Br.	Dags.
Samþykkt	<i>[Signature]</i>		
Drekavellir 54-60, Hafnarfirði		Pakplötur	
Deili		Deili	
Hannað	PJ	Teiknað	PJ
Dagsetning	Verk nr.	Mallikvarði	Teikn. nr.
04.02.07	A-06-12-65	1:20	B-10