

NOTES:
GUTTER TO BE CONSTRUCTED OF 12 GAUGE
T-316, STAINLESS STEEL UNLESS OTHERWISE
SPECIFIED.
CONCRETE, NON-SHRINK GROUT, AND JOINT
SEALANTS ARE NOT PROVIDED.

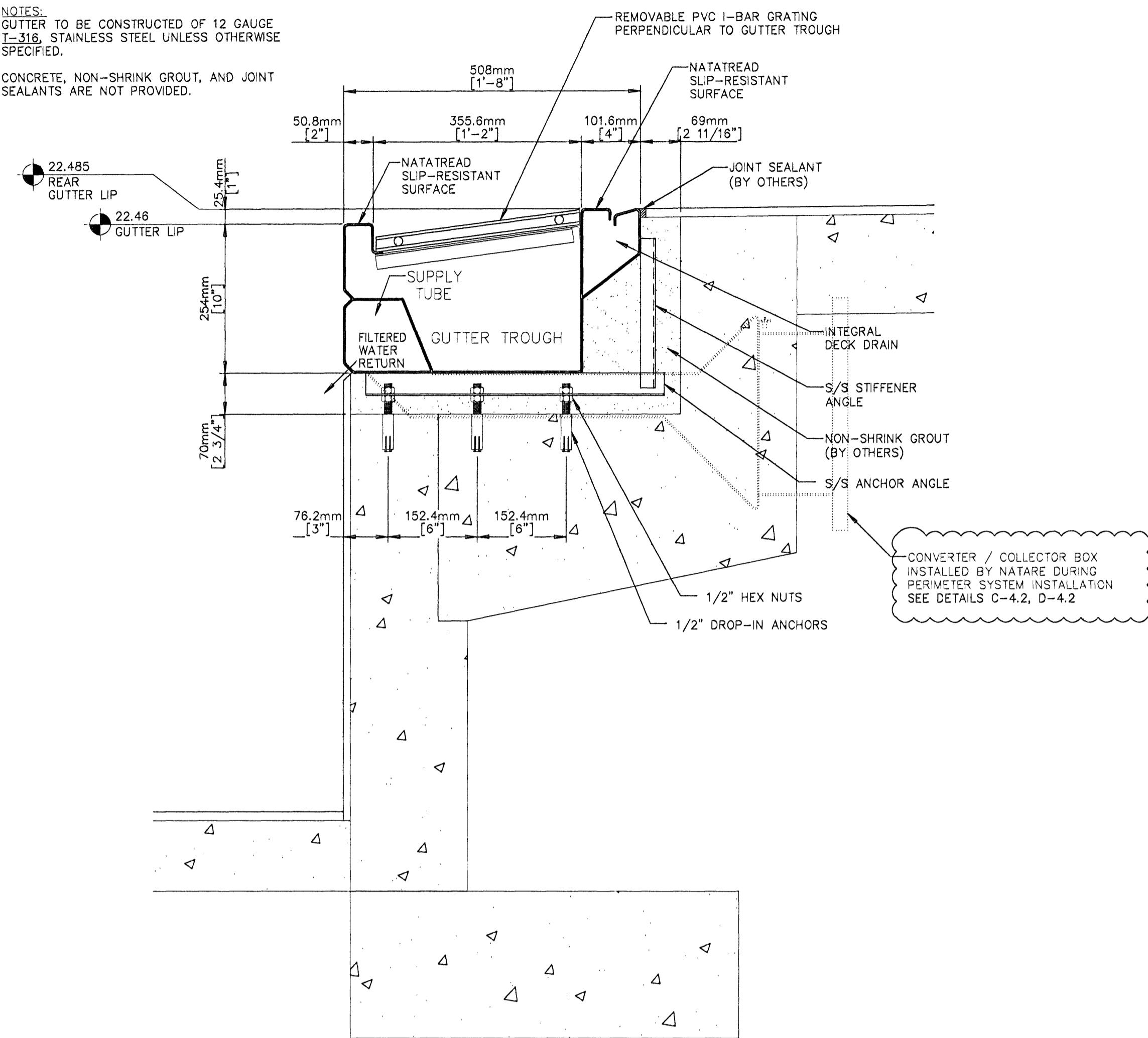

A
4.2
TRAINING
POOL SECTION

SERIES	BEARING BAR THICKNESS	NO. BARS PER SECTION	OPEN SPACE	% OPEN AREA	WEIGHT
36850	1.0" (25.4 mm)	2 to 72	0.315" (8 mm)	31.5%	2.96 psf

NOTES:
1. Natatec grating is manufactured from specially selected, impact resistant, rigid PVC profiles. This grating offers improved toughness and rigidity, dimensional stability and durability. Intended for exterior use, this grating has excellent weatherability and color retention. It is flame retardant and chemically resistant. Typical values are available on request.
2. Top surface of grating is serrated to form a uniform slip-resistant surface. Standard color is white.
3. Natatec grating is intended for use in a swimming pool, aquatic or water feature environment with uniformly supported spans not exceeding 2ft. (600 mm) and uniformly distributed live loads less than 1.025 kg/eq. cm.) For applications involving greater spans or loading conditions, contact our engineering department.

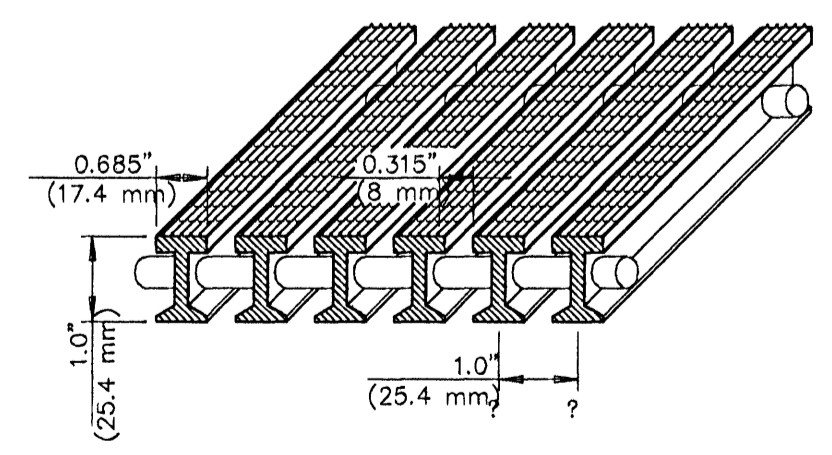

B
4.2
PVC I-BAR GRATING
COLOR: WHITE

NOTES:
1. BOX TO BE FABRICATED FROM 12 ga. T-304 S/S.
2. ENCASE BOX IN CONCRETE POUR.

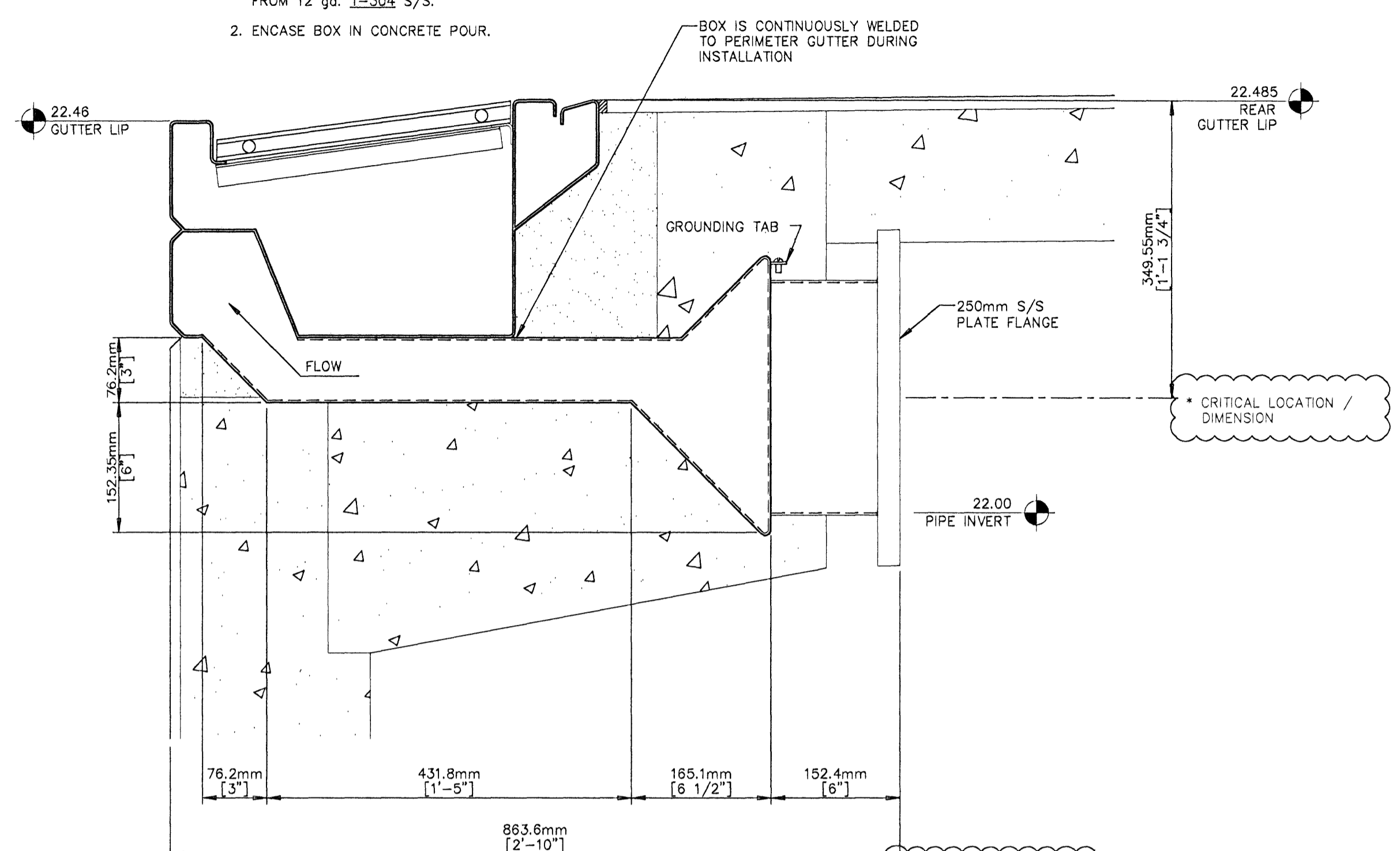

C
4.2
250mm
SUPPLY CONVERTER BOX
QTY.: 1 REQ'D.

NOTES:
1. BOX TO BE FABRICATED FROM 12 ga. T-304 S/S.
2. ENCASE BOX IN CONCRETE POUR.

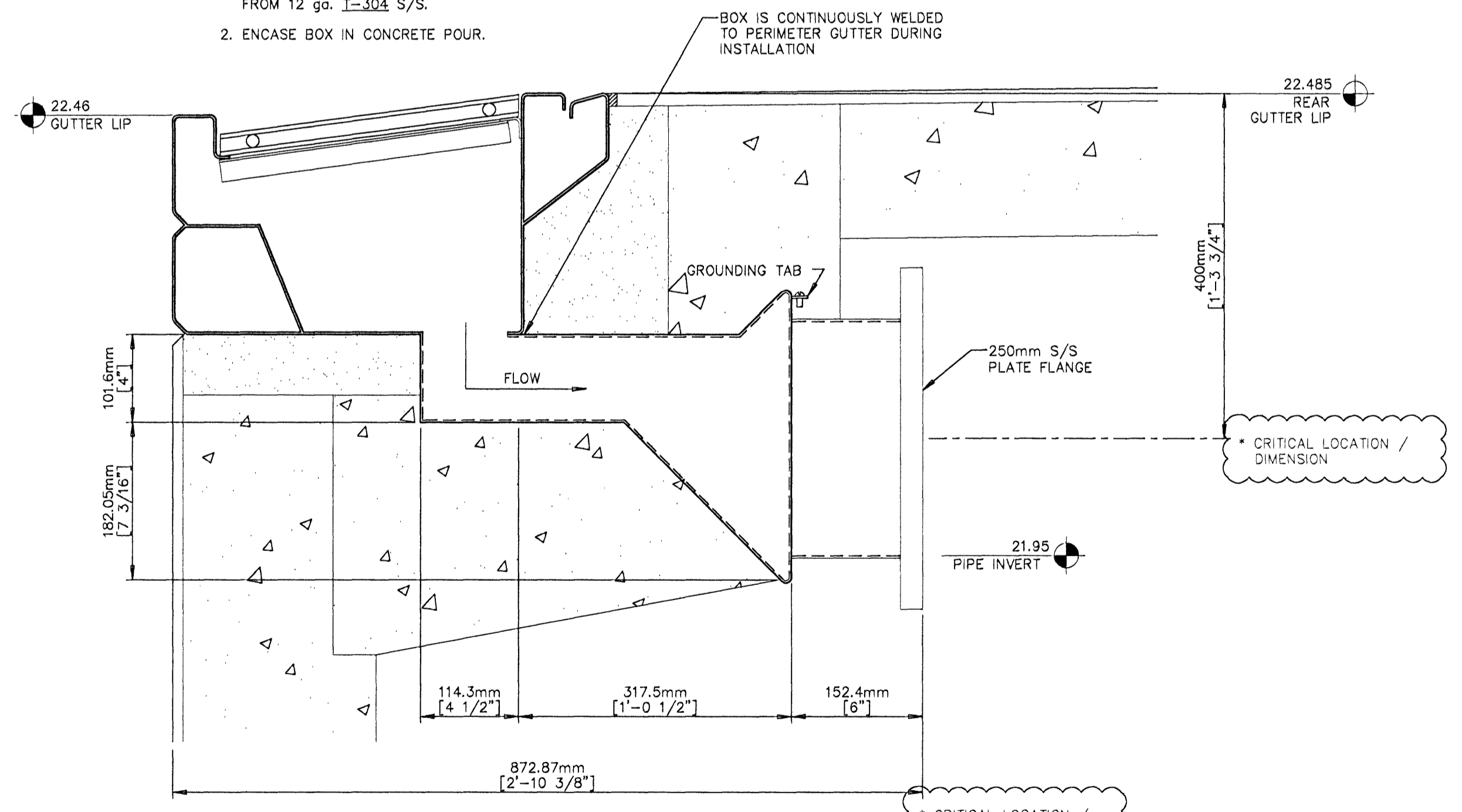

D
4.2
250mm
GUTTER COLLECTOR BOX
QTY.: 2 REQ'D.

1. Do not scale drawings. Refer to or request specific dimensions.
2. Specific dimensions are assumed to be accurate. However, do not use for construction unless verified and certified.
3. Dimensions and details are subject to change without notice unless drawings are certified.
4. For clarity or reference, certain equipment or areas of construction may be shown. Do not assume all items or work illustrated on these drawings to be furnished by Nature Corporation. Refer to equipment schedule or scope of work for specific details.
5. When related work or equipment is shown, such illustration is for information or clarity only. Always refer to appropriate documents for specific details or instructions.

Sundmidstod
Iceland

Samþykkt þann
07 MAI 2008
Byggingartúllitunin í Hafnarfirði
F.h. Hörfur S. Gunnlaugsson

Strendingur ehf.
Kt. 110457-2789

Strendingur ehf.
Fjarvegur 13-15 220 Hafnarfirður
Sími 585 5840 • staða@strendingur.is
www.strendingur.is

NO.	DESCRIPTION	DATE
REVISIONS		

NATURE CORPORATION
5905 W. 74th Street
Indianapolis, In 46278-1786
(317)290-8828
Fax: (317)290-9998

These drawings and the ideas, concepts, illustrations, and written information represented hereby are the property of Nature Corporation and shall not be distributed, copied, reproduced, or utilized in any manner except upon the expressed written consent of Nature Corporation. The recipient hereof acknowledges the confidential and proprietary nature of these drawings and agrees not to use these drawings or the ideas and concepts depicted herein except for the fabrication of the articles depicted herein for and on the behalf of Nature Corporation.

© 2007 NATURE CORPORATION
PAGE TITLE:
TRAINING POOL DETAILS
DATE: 10/5/07
FILE: Training Pool.dwg
LAYOUT: Training Pool Details
DRAWN BY: SAL
CHECKED BY: MTW
PROJECT NO.: SHEET NO.:
4.2