

Bill of material for 1 Ship- POS- 302 total 1 X done

№	Trj pos.	designation	qty	profil	quality	length	weight	řm	
1	3	302	1	RE400	S235JR	1420	2442		
2	3	308	1	RE400	S235JR	370	3880		
3	3	309	1	RE400	S235JR	280	1762		
4	3	309	1	RE400	S235JR	302	1974		
5	3	302	1	RE400	S235JR	280	1956		
6	3	308	1	RE400	S235JR	280	1956		
7	3	308	1	RE400	S235JR	1975	4872		
8	3	309	1	RE400	S235JR	1950	4815		
9	3	308	1	RE400	S235JR	1950	4815		
10	3	309	2	RE200	S235JR	206	3624		
11	3	309	1	RE200	S235JR	70	5169		
12	3	302	1	RE200	S235JR	500	3474		
13	3	304	1	RE200	S235JR	665	3785		
14	3	304	1	RE200	S235JR	540	3139		
15	3	304	2	RE200	S235JR	114	831		
16	3	308	1	RE200	S235JR	210	1247		
17	3	308	1	RE200	S235JR	210	1187		
18	3	308	1	RE200	S235JR	195	1182		
19	3	308	1	RE200	S235JR	799	1938		
20	3	308	2	RE200	S235JR	78	630		
21	3	302	4	RE200	S235JR	70	647		
22	3	304	1	RE200	S235JR	665	3785		
23	3	302	1	FL10405	S235JR	200	539		
24	3	302	4	RE1040	S235JR	540	3561		
25	3	302	2	FL10405	S235JR	400	1884		
26	3	302	2	RE1040	S235JR	231	479		
27	3	308	2	RE1040	S235JR	236	427		
28	3	302	4	RE1040	S235JR	250	848		
29	3	302	4	RE1040	S235JR	250	848		
30	3	304	2	RE1040	S235JR	188	319		
31	3	302	4	RE1040	S235JR	190	577		
32	3	302	4	RE1040	S235JR	192	610		
33	3	302	2	RE1040	S235JR	192	229		
total weight (kg)									154236

Shipping dimensions (l x b x h) 6675 x 300 x 1757

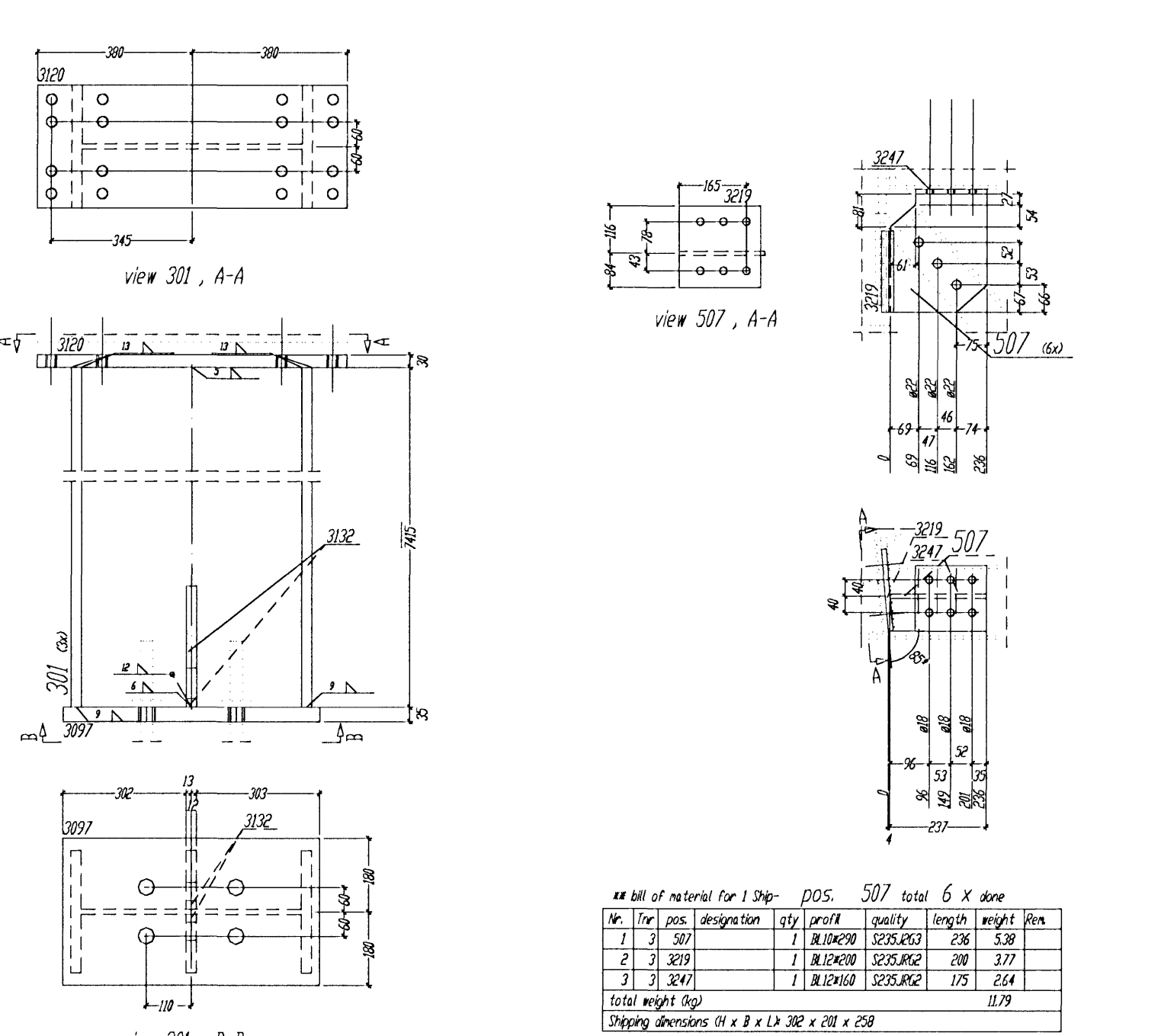

Bill of material for 1 Ship- POS- 301 total 3 X done

№	Trj pos.	designation	qty	profil	quality	length	weight	řm	
1	3	301	1	RE400	S235JR	145	13387		
2	3	307	1	RE200	S235JR	630	6271		
3	3	302	1	RE200	S235JR	780	5369		
4	3	302	2	RE200	S235JR	144	1652		
total weight (kg)									165249

Shipping dimensions (l x b x h) 760 x 360 x 1488

Bill of material for 1 Ship- POS- 307 total 6 X done

№	Trj pos.	designation	qty	profil	quality	length	weight	řm	
1	3	307	1	RE200	S235JR	236	538		
2	3	307	1	RE200	S235JR	280	377		
3	3	307	1	RE200	S235JR	175	264		
total weight (kg)									1179

Shipping dimensions (l x b x h) 382 x 201 x 258

Bill of material for 1 Ship- POS- 509 total 1 X done

№	Trj pos.	designation	qty	profil	quality	length	weight	řm	
1	3	509	1	RE200	S235JR	236	538		
2	3	307	1	RE200	S235JR	280	377		
3	3	307	1	RE200	S235JR	175	264		
total weight (kg)									1179

Shipping dimensions (l x b x h) 382 x 201 x 258

Bill of material for 1 Ship- POS- 511 total 1 X done

№	Trj pos.	designation	qty	profil	quality	length	weight	řm	
1	3	511	1	RE200	S235JR	540	936		
2	3	308	1	RE200	S235JR	311	1634		
total weight (kg)									2570

Shipping dimensions (l x b x h) 382 x 327 x 684

Bill of material for 1 Ship- POS- 513 total 12 X done

№	Trj pos.	designation	qty	profil	quality	length	weight	řm	
1	3	513	12	RE200	S235JR	240	577		
2	3	308	1	RE200	S235JR	236	235		
total weight (kg)									871

Shipping dimensions (l x b x h) 382 x 340

Bill of material for 1 Ship- POS- 517 total 2 X done

№	Trj pos.	designation	qty	profil	quality	length	weight	řm	
1	3	517	2	RE200	S235JR	236	246		
total weight (kg)									492

Bill of material for 1 Ship- POS- 518 total 2 X done

№	Trj pos.	designation	qty	profil	quality	length	weight	řm	
1	3	518	2	RE200	S235JR	125	49		
total weight (kg)									98

Bill of material for 1 Ship- POS- 514 total 3 X done

№	Trj pos.	designation	qty	profil	quality	length	weight	řm	
1	3	514	3	RE400	S235JR	350	178		
total weight (kg)									534

Bill of material for 1 Ship- POS- 515 total 3 X done

№	Trj pos.	designation	qty	profil	quality	length	weight	řm	
1	3	515	3	RE400	S235JR	350	178		
total weight (kg)									534

Bill of material for 1 Ship- POS- 516 total 3 X done

№	Trj pos.	designation	qty	profil	quality	length	weight	řm	
1	3	516	3	RE400	S235JR	350	178		
total weight (kg)									534

Bill of material for 1 Ship- POS- 519 total 1 X done

№	Trj pos.	designation	qty	profil	quality	length	weight	řm	
1	3	519	1	RE200	S235JR	125	49		
total weight (kg)									49

Bill of material for 1 Ship- POS- 520 total 6 X done

№	Trj pos.	designation	qty	profil	quality	length	weight	řm	
1	3	520	6	RE200	S235JR	236	538		
total weight (kg)									3228

Bill of material for 1 Ship- POS- 508 total 1 X done

№	Trj pos.	designation	qty	profil	quality	length	weight	řm	
1	3	508	1	RE200	S235JR	236	538		
2	3	307	1	RE200	S235JR	280	377		
3	3	307	1	RE200	S235JR	175	264		
total weight (kg)									1179

Shipping dimensions (l x b x h) 382 x 201 x 258

Bill of material for 1 Ship- POS- 510 total 1 X done

№	Trj pos.	designation	qty	profil	quality	length	weight	řm	
1	3	510	1	RE200	S235JR	236	538		
2	3	307	1	RE200	S235JR	280	377		
3	3	307	1	RE200	S235JR	175	264		
total weight (kg)									1179

Shipping dimensions (l x b x h) 382 x 201 x 258

Bill of material for 1 Ship- POS- 512 total 1 X done

№	Trj pos.	designation	qty	profil	quality	length	weight	řm	
1	3	512	1	RE200	S235JR	540	936		
2	3	308	1	RE200	S235JR	311	1634		
total weight (kg)									2570

Shipping dimensions (l x b x h) 382 x 327 x 684

Fyrir hönd Conis ehf. tel. 600105-1400
staðfesting að teikning þessi hefur verið
yfirlit. Teikningin er í samræmi við
Íslenska staðla og reglugerðir. 28.10.17

John B
Nafn 130657-01187
Kennitala

Tolerance for welded constructions
According to DIN 9570, Pt.1-3/4/10/87
Welding (W P S) according to
DIN-EN 288 - 2

All unmarked welds to be fillet
continuous a=4mm thick,
not greater than 0.7 d
of the thinner element

The material for cap plates >20 mm thick
to be examined for laminations

BIURO INZYNIERSKIE
Marek i Janina MUCHA
Dzielnia, ul. Polska 30a, 46-070 Komprachcice tel.077-46 46 157

Pos.301-302,507-523

TJARNARVELLIR 11
Steel- Storage house

DRG 201