

BYGGINGARVIRNIR HAFNARFARSK
16 FEB 2008

Bill of material for 1 ship - DOS. 394 total 1 x done

No.	Pos.	Designation	Qty	Profile	Quality	Length	Weight	Part
1	394	1	1	M0808040	S355, A573	3884	44576	
2	3041	1	1	M0808040/1	S355, A573	4694	10839	
3	3043	1	1	M0808040/5	S355, A573	1888	3843	
4	3047	1	1	M0808040/5	S355, A573	1888	3743	
5	3053	2	2	M0808040	S355, A573	1887	4505	
6	3079	1	1	R.154165	S355, A573	214	785	
7	3076	1	1	R.154165	S355, A573	205	2511	
8	3079	1	1	R.154165	S355, A573	201	766	
9	3081	1	1	R.254100	S355, A573	382	2937	
10	3076	1	1	R.154165	S355, A573	219	640	
11	3074	2	2	R.154100	S355, A573	307	1725	
12	3074	1	1	R.154100	S355, A573	339	761	
13	3078	2	2	R.154100	S355, A573	47	164	
14	3040	1	1	R.154165	S355, A573	443	834	
15	3043	1	1	R.154165	S355, A573	295	386	
16	3038	1	1	R.154165	S355, A573	323	426	
17	3038	2	2	R.154165	S355, A573	323	634	
18	3034	2	2	R.154100	S355, A573	67	67	
19	3000	6	6	R.64100	S355, A573	200	630	
20	3000	2	2	R.64100	S355, A573	80	35	
total weight (kg)							63871	
Shipping dimensions of x B x L x 1500 x 686 x 5827								

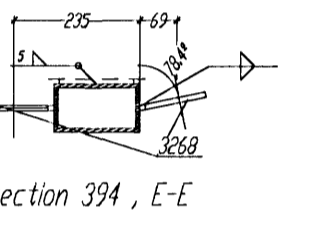
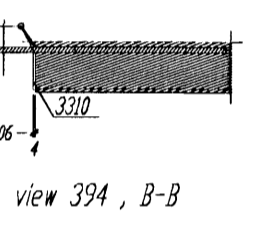
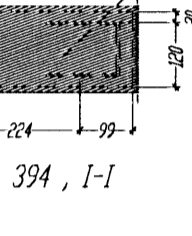
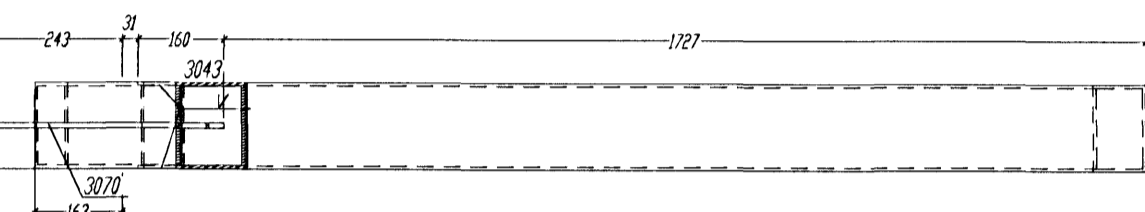
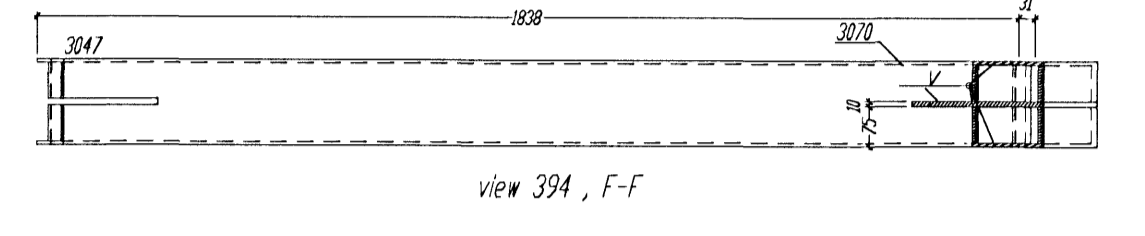
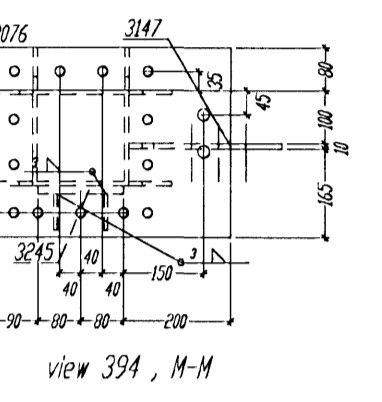
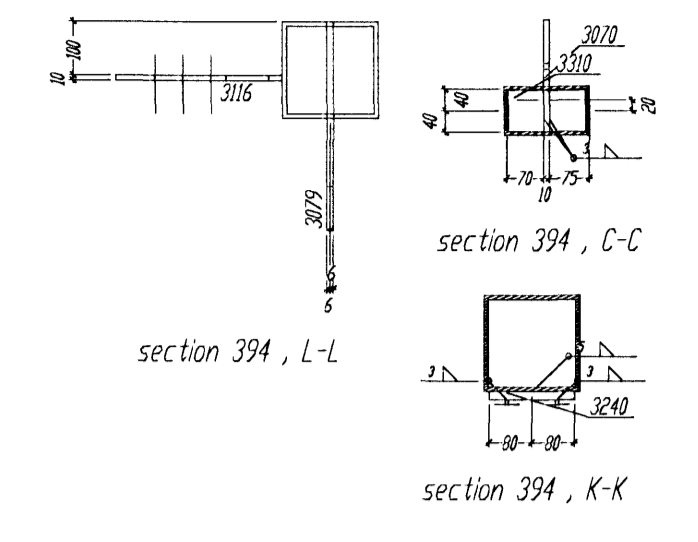

Bill of material for 1 ship - DOS. 395 total 1 x done

No.	Pos.	Designation	Qty	Profile	Quality	Length	Weight	Part
1	395	1	1	M0808040	S355, A573	3884	44576	
2	3041	1	1	M0808040/1	S355, A573	4694	10839	
3	3043	1	1	M0808040/5	S355, A573	1888	3843	
4	3047	1	1	M0808040/5	S355, A573	1888	3743	
5	3053	2	2	M0808040	S355, A573	1887	4505	
6	3079	1	1	R.154165	S355, A573	214	785	
7	3076	1	1	R.154165	S355, A573	205	2511	
8	3079	1	1	R.154165	S355, A573	201	766	
9	3081	1	1	R.254100	S355, A573	382	2937	
10	3076	1	1	R.154165	S355, A573	219	640	
11	3074	2	2	R.154100	S355, A573	307	1725	
12	3074	1	1	R.154100	S355, A573	339	761	
13	3078	2	2	R.154100	S355, A573	47	164	
14	3040	1	1	R.154165	S355, A573	443	834	
15	3043	1	1	R.154165	S355, A573	295	386	
16	3038	1	1	R.154165	S355, A573	323	426	
17	3038	2	2	R.154165	S355, A573	323	634	
18	3034	2	2	R.154100	S355, A573	67	67	
19	3000	6	6	R.64100	S355, A573	200	630	
20	3000	2	2	R.64100	S355, A573	80	35	
total weight (kg)							63871	
Shipping dimensions of x B x L x 1500 x 686 x 5827								

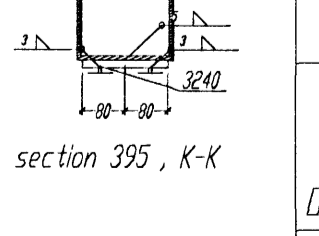
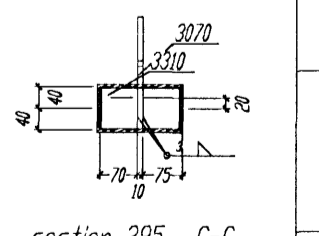
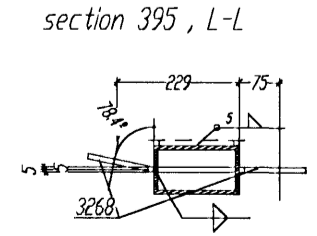
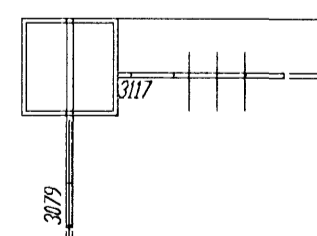
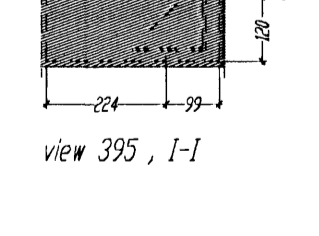
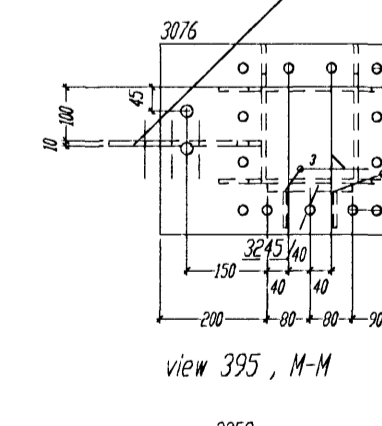
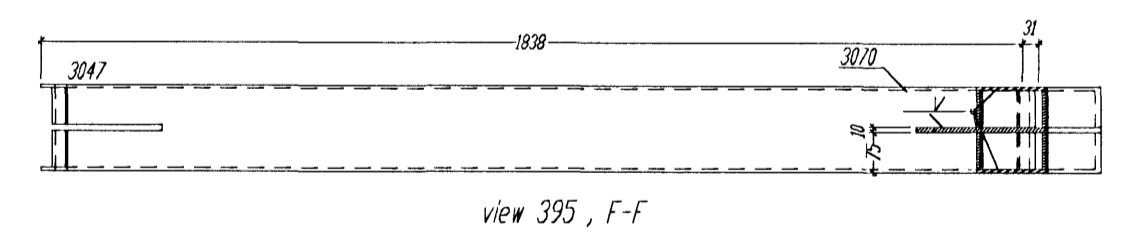
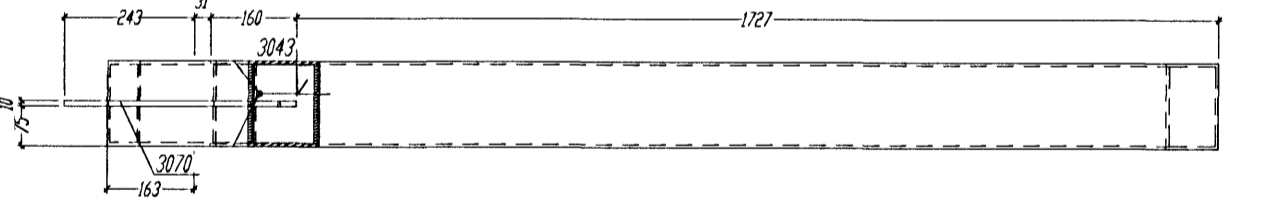

Tolerance for welded constructions according to DIN 8570, PE1+3/BAF.10.87

Welding (W P S) according to DIN-EN 288 - 2

All unwelded joints to be fillet continuous a-fan thick, not greater than 0.7 d of the thinner element

The material for esp. plates >20 mm thick to be examined for laminations

Required torquing/pressing forces and forced tension angles according to DIN 18800 Pt. 7, 05.83

Weld	Weld type	Weld position	Welding process		Welding speed	Welding temperature	Welding direction	Welding angle	Welding force	Welding angle	Welding force
			Welding process	Welding speed							
1	1	1	1	1	1	1	1	1	1	1	1
2	2	2	2	2	2	2	2	2	2	2	2
3	3	3	3	3	3	3	3	3	3	3	3
4	4	4	4	4	4	4	4	4	4	4	4
5	5	5	5	5	5	5	5	5	5	5	5
6	6	6	6	6	6	6	6	6	6	6	6
7	7	7	7	7	7	7	7	7	7	7	7
8	8	8	8	8	8	8	8	8	8	8	8
9	9	9	9	9	9	9	9	9	9	9	9
10	10	10	10	10	10	10	10	10	10	10	10
11	11	11	11	11	11	11	11	11	11	11	11
12	12	12	12	12	12	12	12	12	12	12	12
13	13	13	13	13	13	13	13	13	13	13	13
14	14	14	14	14	14	14	14	14	14	14	14
15	15	15	15	15	15	15	15	15	15	15	15
16	16	16	16	16	16	16	16	16	16	16	16
17	17	17	17	17	17	17	17	17	17	17	17
18	18	18	18	18	18	18	18	18	18	18	18
19	19	19	19	19	19	19	19	19	19	19	19
20	20	20	20	20	20	20	20	20	20	20	20

BIURO INZYNIERSKIE
Marek i Janina MUCHA
Osiny, ul. Opolska 30a, 46-070 Komprachcice tel.071-46 46 757

Pos.394-395

T.JARNARVELLIR 11
Steel-Storage house

DRG 225

Fyrir hönd Conis ehf. kt. 600105-1400
staðfestist að teikning þessi hefur verið
yfirlit. Teikningin er í samræmi við
Íslenska Staða og Reglugerðir. 23/10/07

Kennitala

